



ST. CLAIR CATHOLIC
DISTRICT SCHOOL BOARD

Lighting the Way ~ Rejoicing in Our Journey

TENDER NUMBER: 626-CP1916

Universal Washroom Renovation Project

St. Anne Catholic School

183 Snow Ave., Blenheim, ON N0P 1A0

Submission Deadline and Location:

Tuesday, June 25, 2019

2:00:00 PM Local Time

Reception Desk, Catholic Education Centre

420 Creek Street, Wallaceburg, ON N8A 4C4

1. INTRODUCTION

The St. Clair Catholic District School Board (hereafter referred to as the “SCCDSB” or the “Board”) invites interested parties to submit sealed submissions in response to this Request for Tender (“RFT”) document. The SCCDSB currently operates 26 elementary schools, 2 secondary schools, and an administrative office within the Municipality of Chatham-Kent and County of Lambton.

2. PURPOSE

The purpose of this bid document is to provide interested parties with sufficient information to enable them to prepare and submit bids for consideration by the SCCDSB, subject to the conditions herein.

3. DEFINITIONS

The following words are used throughout the bid document and proponents should note these conditions when completing their bid submission.

The word “MUST” shall mean proponents “must” include the required information in the bid submission. Failure to include the required information will deem the submission informal.

The word “SHOULD” shall mean proponents “should” include the required information in the bid submission.

The word “INFORMAL” shall mean bid submissions will be eliminated from further evaluation if the submission does not include the required information.

The word “CONTRACTOR” means an entity that submits a bid in response to this tender document, as the context may suggest, refers to a potential Contractor.

The word “SUBCONTRACTOR” means the subcontractor and/or business who contracts to provide some service or material necessary for the performance of another’s contract.

The word “QUALIFIED” shall mean a proponent who is compliant and has included the required information in their bid submission.

The word “INFORMAL” shall mean bid submissions will be eliminated from further evaluation if the submission does not include the required information.

“BID IRREGULARITY” means a deviation between the requirements (terms, conditions, specifications, special instructions) of a bid response for the purposes of this bid; bid irregularities are further classified as major irregularities or minor irregularities. The classification of what is a major irregularity or a minor irregularity shall be the sole discretion of the SCCDSB.

“BID SUBMISSION” means all of the documentation and information submitted by a Proponent in response to this request.

“APPLICABLE LAW” and “APPLICABLE LAWS” means any common law requirement and all applicable and enforceable statutes, regulations, directives, policies, administrative interpretations, orders, by laws, rules, guidelines, approvals and other legal requirements of any government and/or regulatory authority in effect from time to time.

The word “PROPONENT” means an entity that submits a bid in response to this tender document, as the context may suggest, refers to a potential Proponent.

4. RFT SCHEDULE

For the purposes of this RFT, the Board has established the following timing deadlines for the completion of the RFT process.

Event	Date & Time
Issue Date:	Friday, May 31, 2019
Mandatory Site Visit:	Thursday, June 6, 2019 at 9:30 AM (Please refer to Section 25)
Last day to submit questions:	Friday, June 14, 2019 at 12:00 PM
Responses to Questions Received :	Tuesday, June 18, 2019
Closing Date and Time:	Tuesday, June 25, 2019 at 2:00:00 PM

5. **RFT CONTACT**

Tony Prizio, Supervisor – Procurement
St. Clair Catholic District School Board
420 Creek Street, Wallaceburg, ON
P: (519) 627-6762 x10256
E: tony.prizio@st-clair.net

6. **ACCEPTANCE OF TERMS**

The submission of a bid by a Proponent represents that the Proponent has read and completely understands, and accepts all provisions contained within this RFT. Any bid that has alternative terms and conditions to those contained herewith may be considered a counteroffer to the Board’s request and may be rejected.

7. **SCOPE OF WORK**

The St. Clair Catholic District School Board is seeking a contractor to provide all of the necessary materials, equipment, and labour to complete a new universal washroom at St. Anne Catholic School, 183 Snow Ave, Blenheim, ON.

8. **BID SUBMISSION**

Bids shall be submitted with the project clearly identified on the sealed envelope:

Bid Package #: 629-CP1916 – Universal Washroom - St. Anne Catholic School, Blenheim

The sealed Bid Submission must be returned to:

Catholic Education Centre, 420 Creek St. Wallaceburg, ON N8A 4C4

Attention: Mr. Tony Prizio, Supervisor - Procurement

Bids MUST be received no later than the date and time specified in this tender document. Any bid submissions received after the deadline will be returned unopened to the bidder.

The Board will not take any responsibility for late submissions due to postal delay through Canada Post or other courier services.

Bids shall be filled out in ink or typed, signed in longhand by a duly authorized company official (having authority to bind) and sealed with a company corporate seal. One original of the fully completed Bid Form must be submitted. Failure to provide all of the requested information on the Bid Form may result in disqualification of the bid.

Bids by telephone or fax will not be accepted.

After bid closing all submissions will be reviewed by the Board's evaluation team. Contractors submitting a bid are invited to stay for a public opening of Bids at 2:05 pm at the Catholic Education Centre.

Supplier's Bid Submission, all Bid Documents and a Purchase Order will form the agreement.

9. CONTRACT PRICING

Proponents must complete the Bid Form provided with these bid documents. Prices must include all travel, reimbursements, delivery (FOB Destination).

10. QUESTIONS AND REQUESTS FOR CLARIFICATION

Proponents finding discrepancies, ambiguities or omissions in the RFT documents or having doubt as to the meaning or intent thereof, shall immediately notify the Procurement Department. The board is not responsible for any misunderstanding of the RFT on the part of a Proponent. Questions must be received by the date and time specified in the RFT Document

All questions to be addressed in writing to: [Tony Prizio](mailto:Tony.Prizio@st-clair.net), Supervisor - Procurement
St. Clair Catholic District School Board
E-mail: tony.prizio@st-clair.net
CC: victoria.iaccino@st-clair.net

11. ADDENDA

Proponents may also, during the RFT Process, be advised by Addendum of any additions, deletions or alterations to RFT documents. All such Addenda shall become part of the RFT Documents.

If an addendum is issued, the document(s) will be made available to Proponents through the same platform that the original RFT documents were issued. Proponents are responsible for verifying before submitting its response that it has received all addenda that may have been issued.

12. WITHDRAWAL OF SUBMISSION

A Proponent may alter, amend, or withdraw a submitted proposal if such request is received in writing by the contact person for this RFT prior to the closing date and time specified in this document. The last submission shall supersede and invalidate all previous submission by that Proponent as it applies to this bid. Such requests received after the closing date and time will not be permitted.

13. BID ACCEPTANCE

It shall be understood by all proponents, that the RFT submission shall be valid and subject to acceptance by the Board, and that no adjustments shall be made to the proposal for a period of up to and including sixty (60) days from the RFT Closing Date.

The Board reserves the right to determine the successful proponent at its sole discretion. The lowest cost may not be accepted. The Board reserves the right to decline any or all submissions, in whole or in part, at any time prior to making an award.

The successful proponent shall be required to enter into a formal contract with the Board, which will include the terms and conditions of the RFT documents, the Proponent's bid, and all other applicable documents.

14. CANCELLATION

The Board may cancel this RFT at its discretion at any time prior to an award. The Board may do so without providing reasons and issue a new request for tender, request for qualifications, or do nothing.

15. CLARIFICATION

The Board reserves the right to seek clarification from any Proponents without being obligated to all Proponents if it finds certain aspects of a bid unclear.

16. BOARD'S RIGHT TO WAIVE MINOR IRREGULARITY

The Board reserves the right to accept or waive a minor irregularity, or where practical to do so the Board may as a condition of bid acceptance request a Proponent to correct a minor irregularity with no change in bid price. Items of non-compliance on any bid submissions which do not strictly comply with the provisions, procedures and requirements of this bid, or are incomplete, ambiguous, or which contain errors, alterations, misleading information, omissions, or irregularities of any kind, may be rejected and disqualified at the discretion of the Board. All proponents agree to provide all such additional information as, and when requested, at their own expense, provided no proponent in supplying any such information shall be allowed, in any way to change the pricing or other cost quotations originally given in its bid submission or in any way materially alter or add to the solution originally proposed.

17. ERRORS AND OMISSIONS

The Board will not be held liable for any errors or omissions in any part of the RFT. While the Board has used considerable effort to ensure an accurate representation in the RFT, the information contained in the RFT is supplied solely as a guideline for the Proponents. The information is not guaranteed or warranted to be accurate by the Board, nor is it necessarily comprehensive or exhaustive.

18. DOCUMENT AVAILABILITY

RFT documents are available on the Board's Website www.st-clair.net under Bid Opportunities or on Biddingo www.biddingo.com, along with Sarnia Construction Association, Windsor Construction Association, Lambton Area Builders Exchange and the London & District Construction Association.

The Board assumes no responsibility for the proponent's failure to examine all of the RFT Documents.

19. PROPONENT EXPENSES

Any and all costs and expenses incurred by Proponents in the development, preparation, submission or presentation of their bids, or otherwise related to its participation in this RFT process will be borne by the Proponents. The selection of any bid, or the rejection of any or all bids, or the termination/cancellation of this RFT process, or initiation of a new RFT process shall not render the Board liable to pay or reimburse any such costs or damages incurred by any Proponent, or any partner or contractor of such Proponents.

20. VOLUNTARY ALTERNATE & SEPARATE PRICES

The bid amounts are to be based on the bid documents. Where there is any conflict within the bid documents, the bid amount shall include the higher cost alternative. Alternative proposals are encouraged and should be identified in the bid. Submit complete information including any impact on

schedule to allow a full evaluation of the proposal including, as applicable, any particulars in which the alternate proposal is at variance with or unable to meet the specifications. Note also any impact on other trades if the alternative is accepted. Alternative proposals may be made without limitation, including for items specified as single sourced

21. BID INELIGIBILITY

Bids that are unsigned, improperly signed or sealed, conditional, illegible, obscure, contain arithmetical errors, erasures, alterations, or irregularities of any kind may, at the discretion of the Owner, be declared informal.

Bids with Bid Forms and enclosures which are improperly prepared may, at the discretion of the Owner, be declared informal.

Bids that fail to include the required bonding, consent of surety may, at the discretion of the Owner, be declared informal.

Bids based on prices seeming to be so unbalanced as to adversely affect the interests of the Owner may, at the discretion of the Owner, be declared informal.

Bids based upon an unreasonable period of time for completion of the Work may, at the discretion of the Owner, be declared informal.

Bids that do not include Proof of Insurance may, at the discretion of the Owner, be declared informal.

22. AWARD

The Board has the right to reject any or all bids. The lowest Bid will not necessarily be accepted. The invitation to bid does not constitute an offer by the Contractor to enter into a contract. In the event of a tie, a coin flip conducted by the Supervisor – Procurement (or designate) with a minimum of one other Board staff will determine the successful proponent.

Acceptance of the Bid and/or award is subject to the approval of the St. Clair Catholic District School Board.

The SCCDSB reserves the right to withdraw the award of the contract to a successful bidder(s) within 30 days of the award if, in the opinion of the SCCDSB, the successful bidder(s) is unable or unwilling to enter into a form of contract satisfactory to the SCCDSB. The SCCDSB shall be entitled to do so without any liability being incurred by the SCCDSB to the bidder.

23. ENTITLEMENT TO A DEBRIEFING

In accordance with the Broader Public Sector Procurement Directive unsuccessful Bidders are entitled to a debriefing, during which they will be provided with feedback regarding their Tender. In order to be debriefed, unsuccessful Bidders must contact the Owner representative identified in the Bid Documents in writing to request a debriefing within sixty (60) days from the date of the notification of award.

24. BID DISPUTE PROCEDURE

In the event that a Bidder wishes to review the decision of the Board in respect of any material aspect of the Request For Tender process, the Bidder shall submit a protest in writing to the Board to the attention of the Supervisor – Procurement within ten (10) days of the closing date of the Tender.

Any protest in writing shall include the following:

- a) a specific identification of the provision and/or procurement procedure that is alleged to have been breached;
- b) a specific description of each act alleged to have breached the procurement process;
- c) a precise statement of the relevant facts;
- d) an identification of the issues to be resolved;
- e) the Bidder's arguments and supporting documentation;
- f) the Bidder's requested remedy.

25. EXAMINATION OF SITE & SITE VISIT

Location: St. Anne Catholic School, 183 Snow Ave, Blenheim, ON

Instructions: Report to the Main Office to sign-in at the time listed in this RFT.

Contact: Paul Lernout – Cell: 519-360-6262

This is a MANDATORY SITE VISIT. Only contractors who attend the site visit will be permitted to submit a bid response. Attendance will be taken and will form part of the Bid Documents. Representatives of the Owner and Consultant will be in attendance.

In submitting a bid, it will be assumed that the bidders have carefully examined the drawings and have included in the bid price the complete cost of the work contemplated by the drawings and specifications and other bid documents.

26. TIMING OF PROJECT

The schedule for the completion of the project is:

- Commencement no earlier than June 28, 2019.
- Substantial Performance no later than August 23, 2019

Work is to be completed during normal business hours. Working outside of school hours, including daytime access during weekends, holidays, March break, etc. shall be at the sole discretion of the SCCDSB's Project Manager.

27. INVOICING & PAYMENT

The Board shall pay by electronic funds transfer (EFT), P-Card, or cheque within thirty (30) days after the receipt of a proper invoice. Invoices will be reviewed and certified by the Board's Consultant, if applicable, before the invoice is processed for payment. Invoices must include all back-up material for time and material charges, disbursements, and other fees. Please make reference to the Purchase Order number on the invoice.

Note: Invoices should reflect a 10% holdback (final construction cost) which will be retained by Board through substantial completion of the project.

28. TAXES

Include in Bid all Taxes and all other Customs Duties and Excise Taxes which are in force at Bid date as detailed in General Conditions. Harmonized Sales Tax (H.S.T.) is **not** to be included in the bid. The H.S.T. amount and the Bidder's **H.S.T. Registration Number** are to be indicated on the Bid Form in the spaces provided.

29. CHANGE NOTICES, CHANGE ORDERS

The following fee percentage and overhead charges shall be applied to additional work ordered by the Board:

- For work carried out by the Contractor's own forces – 10% Overhead & 5% Profit
- For work carried out by Subcontractors – 5% Overhead & 5%
- Credits – 0% Overhead & 0% Profits

30. PROJECT SPECIFIC REQUIREMENTS

Any and all damages to facilities while under the control of the contractor shall be repaired at the contractor's cost. Please be advised that the Owner has a No Smoking Requirement on the Owners' property. Contractors shall provide their own washroom facilities for their employees; board washrooms will be off limits to the contractor's employees. Contractors are requested to ensure that employees and suppliers are advised of these Requirements. Contractor shall remove rubbish and debris from the site on a daily basis or as directed by the Board. On completion of the work, all debris shall be removed; the floor shall be thoroughly cleaned and swept; the site shall be left in a tidy condition (construction clean). Do not use the Board's equipment or facilities for cleaning or for any reason.

31. SUBCONTRACTORS

The successful Proponent(s) may not, at any time, subcontract any portions of its contract with the Board nor shall it assign the contract without the written permission of the Board. The successful Proponent(s) must not, at any time, change subcontractors approved by the Board without the written permission of the Board.

32. GENERAL TERMS AND CONDITIONS

The issuance of this tender shall not constitute an obligation on the part of the Board to any proponent who submits a bid

The laws of the Province of Ontario shall govern any dispute occasioned as a result of the performance or non-performance and/or workmanship of a contract issued pursuant to the bid and any dispute arising out of the issuance of and response to this bid.

All SCCDSB policies, procedures and regulations must be adhered to by the successful bidder(s).

Some of the Board sites are equipped with video surveillance cameras.

The successful proponent(s) is obliged to cooperate with all recycling and environmental procedures and initiatives established by government, the Board and each school.

The successful bidder(s)' employees and contracted staff shall not be considered SCCDSB employees and shall not represent themselves as an agent of the SCCDSB nor be eligible for any of the benefits provided to SCCDSB employees.

The SCCDSB reserves the right to demand the removal of any successful bidder's employees or contracted staff engaged in this contract if, in the SCCDSB's opinion, their conduct has been of an unacceptable nature.

The successful bidder(s) will be responsible for ensuring that regular supervision is maintained over all working personnel. It is the bidder's responsibility to ensure that all their activities are properly coordinated with the SCCDSB's operations and modify assignments as required.

This tender document is being issued pursuant to the SCCDSB's Purchasing Policies and Procedures.

The acceptance of the bid by the successful proponent(s) and the award of the contract contemplated by this bid document may be subject to approval of the Board of Trustees.

33. BONDING

On bids exceeding \$100,000.00 (inclusive of all taxes) the following tender security / bonding is required and must accompany the bid:

- Agreement to Bond: 50% Performance and 50% Labour and Material
- Bid Bond: 10% of the bid price, payable to the St. Clair Catholic District School Board

If the bid amount is greater than \$100,000 and less than \$500,000 (inclusive of all taxes) the Surety or Bid Bond may be provided in the form of an irrevocable letter of credit, a certified cheque, or money order payable to the Board in the value of 10% of the bid amount.

Only bond and agreements to bond issued by a licenced Canadian surety company authorized to do business in the Province of Ontario will be accepted. Upon request, the successful Bidder will be required to present the bonds to the Purchasing Department. Failure to provide the proper surety to the Board upon award will result in rejection of that Bid. The cost of bonding shall be included in the Bid price and identified on the Tender Form, if applicable

34. INSURANCE

Contractor must maintain, at the Contractor's expense for the entire term of the Contract or as otherwise required, all insurance as set out below. If subcontractors are being used as part of the contract, the Contractor must ensure all Subcontractors have insurance coverage.

- The successful Contractor shall provide the Board with proof of insurance for Comprehensive General Liability and Property Damage with a limit of not less than **\$5,000,000.00 (five million dollars)** included in the bid submission.
- The successful Contractor shall provide the Board with proof of insurance for Motor Vehicle Public Liability and Property Insurance on all owned and rented equipment with a limit of not less than **\$2,000,000.00 (two million dollars)** included in the bid submission.
- The Contractor agrees to indemnify, hold harmless, and defend the Board from and against any and all liability for loss, damage and expense, which the Board may suffer or for which the Board may be held liable by reason of injury (including death) or damage to any property arising out of negligence on the party of the proponent or any of its representatives, employees, or subcontractors in the execution of the work performed or by way of ownership or operation of an automobile.
- The successful Contractor shall provide the Board with a complete certified copy of all policies. Copies of renewed policies must be provided to the Board on or before the policy renewal date for projects that extend past the original policy term or for multi-year contracts.

- The successful Contractor must name the St. Clair Catholic District School Board as additional insured on their insurance policies.

35. WORKPLACE SAFETY INSURANCE BOARD (WSIB)

Contractor must furnish a copy of Workplace Safety and Insurance Board Clearance Certificate of good standing, "Section 748" of the Workplace Safety and Insurance Act included in the bid submission. If subcontractors are being used as part of the contract, the Contractor must ensure all Subcontractors have WSIB coverage.

36. PERMITS

The Board will apply and pay for a building permit if applicable. The contractor is to obtain all other permits as required to complete the project, including but not limited to ESA, hot work permit etc.

37. MEETINGS

A Post Bid Meeting may be convened and chaired by the Board who will invite Contractor and his major Subcontractors to review the Contract Documents and Bid submitted. This meeting will be prior to the Board issuing a Letter of Intent or Contract. This meeting does not constitute or infer any contract award to the proposed contractor or any other contractor, nor that will the project proceed.

During the course of Work, scheduled progress meetings may be required at the call of the Project Leader.

38. GUARANTEE

The guarantee shall be for a period of 1 year from and after completion of the entire job and acceptance thereof by the Board unless a different period of time is specified with the Board's approval. The Contractor's guarantee shall cover all work under the Contract whether or not any portion or trade has been sublet.

The Contractor agrees to correct promptly, at the Contractor's own expense, defects or deficiencies in the Work which appear prior to and during the period of guarantee, or such longer periods as may be specified for certain products or work.

If the Contractor fails to make any replacements or repairs required hereunder, after notice from the Board and reasonable opportunity to do so, the Board may have such work done at Contractor's expense, including all necessary labour costs in connection therewith. Board shall inform Contractor in advance of the approximate cost of such work to be done by the Board.

39. SCHEDULE

The Contractor will be required to perform the work in accordance with the Schedule dates provided in 26. Timing of Project. Ordering of major and long delivery items shall begin immediately upon successful bidder's receipt of contract award. The Contractor will provide a construction schedule within five (5) days of being awarded the project.

Time is of the essence. Bidders are to include adequate manpower, overtime and shift work necessary to meet or improve the schedule, and to make up any time lost to weather or normal delays. Include travel, room and board costs for out of town workers, shop overtime and other premiums to expedite material and equipment, shipping premiums and any incentive costs required to meet the schedule.

40. CONTRACTED SERVICES PROGRAM

Contractors performing work on Board property must complete the Contracted Services Program. The Contracted Services Program is a joint program with Lambton Kent District School Board. This program has three basic components that **must** be met before the bid is awarded. Contractors who cannot meet the minimum requirements of this program will not be awarded this tender. Program information can be found on the Board's web site at www.st-clair.net or through the Board contact identified previously in this document. If the contractor has already been pre-qualified by LKDSB they must provide proof of completion. Identification badges can be used on SCCDSB or LKDSB property. All Insurance and WSIB certificates must be up to date under the Contracted Services Program.

41. HEALTH and SAFETY

The Occupational Health and Safety Act describes the responsibilities of an employer. The Board requires Contractors to maintain procedures, training, and enforcement so that the responsibilities are carried out in the workplace. The Contractor shall abide by and strictly adhere to the regulations and conditions set out and laid down by the most current versions of the Occupational Health and Safety Act. All staff employed or hired by the Contractor and working on the Board's premise **MUST** be trained in WHMIS in accordance with Occupational Health and Safety Act and Regulations. They **MUST** adhere to all of the Board's Health and Safety Procedures and Guidelines and to Municipal By-Laws.

Contractor will submit proof of its health and safety program, procedures and training as detailed above upon request by the Board.

The Contractor shall appoint a Competent Person as the Supervisor of this project. The Competent Person shall be as defined in Section 1 of the Occupational Health and Safety Act.

The successful Contractor shall conform to the Ontario "Occupational Health and Safety Act" and all regulations made under said act and assume full responsibility for contraventions of same.

All workplace injuries or accidents on Board property **MUST** be reported by the Contractor to the Board's representative within 24 hours.

Any workplace injury that is defined under the Occupational Health and Safety Act as a "Critical Injury" must be reported to the Board's representative **IMMEDIATELY**.

42. CANADIAN STANDARDS ASSOCIATION (C.S.A.)

All electrical/electronic components supplied by the vendor/contractor must be CSA / ULC and/or Ontario Hydro/Ontario Electrical Safety Authority approved. Appropriate labels must be affixed to the equipment.

43. DESIGNATED SUBSTANCES

The contractor shall conduct work in recognition of the most current regulations related to Designated Substances. The contractor is required to review the site specific designated substances report to ascertain potential for exposure to designated materials and notify the board of instances where the scope of work under this contract will require remediation. If the report does not schedule designated materials in the attached report and should the contractor uncover material which is believed to be asbestos, work is to cease immediately and the Board staff are to be contacted immediately.

44. SAFE SCHOOL PROCEDURES

Contractor's staff is required to report to the main office of the site where work will be carried out during regular school hours and notify the school office staff of the purpose of the visit. The Contractor is required to adhere to all school specific procedures if applicable.

It is the responsibility of the Contractor's staff to sign in and sign out of the Log Book, which is located in the main office area, while performing their duties.

The following information must be recorded in a legible manner:

- Date
- Company Name
- Employee Name
- Employee Signature
- Reason for Visit
- Time Entering Building
- Time Leaving Building

45. HOISTING, SCAFFOLDS, ELEVATED WORK PLATFORMS

The Contractor is responsible for all hoisting and other equipment necessary to facilitate their work.

46. TEMPORARY POWER

A source of electric power will be designated by the Board. The Board will allow a tie-in connection with fuse or breaker protection for the Contractor's estimated load requirements. The Contractor must provide the power connections and all extensions from the point to the job site. All electrical connections and extensions must meet ESA requirements and must be approved by the Board. The Contractor's estimated load requirements must not be exceeded without the Owner's permission.

47. NOISE AND TRAFFIC CONTROL

Bidders shall comply with all applicable **noise by-laws** (or local requirements governing same) and traffic routing that may be in effect during the life of the Project.

This **may** limit some activities to restricted time periods. Where the schedule requires for after hour work, the Contractor shall include all costs associated with obtaining the necessary permits to work such time periods.

The Contractor shall be responsible for all costs associated with providing a traffic officer as necessary to facilitate construction.

48. SITE ACCESS AND EGRESS

Contractors will be required to sign out a master key and will be assigned an access code for the alarm system. Successful Contractor will be responsible for building security during working hours and locking up the facility at night, which includes setting the alarm.

Any false alarms generated by the Contractor's workforce will result in a back charge for the costs incurred to the Board.

The Contractor shall make good any damage to roads, curbs, sidewalks, fencing, or grass damaged by vehicles or equipment during the course of construction.

49. PARKING

Contractors must park within the designated areas and allow for provisions to and from the designated parking area onto the job site.

50. CONTRACTOR'S PERSONNEL

The Contractor shall, at its own expense, provide all the personnel required to take a proactive role in managing the project as it relates to their work and its coordination with other trades. This will include but is not limited to the following:

- Competent supervision of the work of the Contract and coordination with the work of other Subcontractors. This includes being responsible for and properly supervising any subcontractors of this subcontractor.
- All layout work required to complete the work of the trade contract.
- Competent supervision of the work of the trade contract to ensure work is done in accordance with the OHSA and any other applicable regulations.
- Expediting the procurement of material and equipment to ensure delivery by their required dates.
- Submission of Requests for Information where required in a timely manner and wherever possible providing the Board with information to assist in the answering of these requests.
- Submission in a timely manner of all required shop drawings and samples and assistance to the Board required to obtain approvals to suit the schedule. All shop drawings are to be reviewed by the Contractor prior to submitting for approval.
- Attendance at all construction coordination meetings when requested by the Board.
- Provision of all necessary information requested by the Board for cost control and billing purposes.
- Inspection of the work of the Trade Contract for defects and deficiencies and cooperation with the Board and other inspection authorities to allow their inspections to take place.
- Submission of pricing for all changes to the work within five (5) working days after receipt of change documentation including the breakdown and backup necessary to allow checking and approval.

51. ACCESSIBILITY FOR ONTARIANS WITH DISABILITIES ACT

The Purchaser is committed to the highest possible standards for accessibility. Proponent(s) must be capable to recommend and deliver, as appropriate for each Deliverable, accessible and inclusive Services consistent with the Ontario Human Rights Code (OHRC), the Ontarians with Disabilities Act, 2001 (ODA) and Accessibility for Ontarians with Disabilities Act, 2005 (AODA) and its regulations in order to achieve accessibility for Ontarians with disabilities.

In accordance with Ontario Regulation 429-07 made under the Accessibility for Ontarians with Disabilities Act, 2005 (Accessibility Standards for Customer Service), the Purchaser has established policies, practices and procedures governing the provision of its services to persons with disabilities.

Proponents are required to comply with the Purchaser's accessibility standards, policies, practices, and procedures, which may be in effect during the Term of the Agreement and which apply to the Deliverables to be provided by the Proponent.

52. CANADA'S ANTI-SPAM LEGISLATION

Please note that vendors are required to comply with all applicable laws, including CASL, in providing goods or services to the Board. This also extends to communications sent on the Boards behalf. The successful proponent(s) will be required to indemnify the Board for any failure by the successful proponent(s) to comply with CASL, to the extent that the successful proponent(s) action, or inaction, could expose the Board to liability.

53. CONFIDENTIAL INFORMATION

All correspondence, documentation, and information of any kind provided to any Proponent in connection with or arising out of this Request for Tender or the acceptance of any Bid:

- Remains the property of the Purchaser and shall be removed from the Purchaser's premises only with the prior written consent of the Purchaser.
- Must be treated as confidential and shall not be disclosed except with the prior written consent of the Purchaser.
- Must not be used for any purpose other than for replying to this RFT and for the fulfilment of any related subsequent agreement.
- Must be returned to the Purchaser upon request.

Except as provided otherwise in this request, or as may be required by Applicable Laws, the Purchaser shall treat the Proponents' Proposals and any information gathered in any related process as confidential, provided that such obligation shall not include any information that is or becomes generally available to the public other than as a result of disclosure by the Purchaser.

During any part of this Request for Tender process, the Purchaser or any of its representatives or agents shall be under no obligation to execute a confidentiality agreement.

All correspondence, documentation, and information provided in response to or because of this RFT may be reproduced for the purposes of evaluating the Proponent's Bid Submission.

If a portion of a Proponent's Bid Submission is to be held confidential, such provisions must be clearly identified in the Bid.

The Purchaser reserves the right to require any Proponent to enter into a non-disclosure and/or confidentiality agreement satisfactory to the Purchaser.

54. MUNICIPAL FREEDOM OF INFORMATION AND PROTECTION OF PRIVACY ACT

The *Municipal Freedom of Information and Protection of Privacy Act* (Ontario) applies to information provided by Proponents. A Proponent should identify any information in its Quotation or any accompanying documentation supplied in confidence for which confidentiality is to be maintained by the Purchaser. The confidentiality of such information will be maintained by the Purchaser, except as otherwise required by law or by order of a court, tribunal, or the Ontario Privacy Commissioner.

By submitting a Bid, including any Personal Information requested in this RFT, Proponents agree to the use of such information for the evaluation process, for any audit of this procurement process, and for contract management purposes.

55. TRADE AGREEMENTS

Proponents should note that procurements coming within the scope of either Chapter 5 of the Canadian Free Trade Agreement, Chapter 19 of the Comprehensive Economic and Trade Agreement or any other

applicable agreement not listed herein are subject to such agreements, although the rights and obligations of the parties shall be governed by the specific terms of this RFT.

56. WORKPLACE HAZARDOUS MATERIALS INFORMATION SYSTEM

The Proponent should provide Workplace Hazardous Materials Information System (WHMIS) material safety data sheets (MSDS) for all Services. Additionally, the Proponent should provide the Purchaser's personnel WHMIS training, as it relates to the Services, in accordance with the Ontario Occupational Health and Safety Act.

57. VENDOR PERFORMANCE

Where the Contractor fails to comply with any of its obligations under the Contract, the Board may issue a notice setting out the manner and time-frame for rectification. Within seven (7) Business Days of receipt of that notice or in a timeframe as otherwise agreed to, the Contractor shall either: (a) comply with that rectification notice; or (b) provide a rectification plan satisfactory to the Board. If the Contractor fails to either comply with that rectification notice or provide a satisfactory rectification plan, the Board may immediately terminate the Contract. Where the Contractor has been given a prior rectification notice, the same subsequent type of non-compliance by the Contractor may allow the Board to immediately terminate the Contract and result in the suspension of bidding privileges to the Board for up to two years at the sole unfettered discretion of the Board.

58. TERMINATION OF CONTRACT

Either party may terminate the Agreement on written notice to the other where such other party neglects or fails to perform or observe any material term or obligation of the Agreement and such failure has not been cured within 30 Days of written notice being provided.

The Board shall be entitled to terminate the Agreement, without liability, cost, or penalty:

- On written notice to the Proponent, if any proceeding in bankruptcy, receivership, liquidation, or insolvency is commenced against the Proponent or its property;
- On written notice to the Proponent, if the Proponent makes an assignment for the benefit of its creditors, becomes insolvent, commits an act of bankruptcy, ceases to carry on its business or affairs as a going concern, files a notice of intention or a proposal, or seeks any arrangement or compromise with its creditors under any statute or otherwise;
- Or at any time, without cause, by giving the Proponent at least 60 Days written notice.

END OF INSTRUCTIONS TO BIDDERS

APPENDIX A: Agreement of Terms

I hereby acknowledge and agree that I have read and completed all the preceding Contract Terms and Conditions and Appendices.

I understand it is the SCCDSB's intention that this tender and the successful proponent(s)'s returned tender submission will form the basis of the proposed contract. All of the terms and conditions of this Tender must be accepted by the proponent(s) and incorporated into the proponent(s) Tender submission. It is the SCCDSB's intention to use a Purchase Order when establishing a contract with the successful proponent(s).

Acknowledgement of Addenda _____ through _____

This page must be signed below and returned with your submission for your tender to be accepted.

I/We the undersigned are duly authorized to execute this Bid Submission on behalf of:

COMPANY: _____

NAME/ TITLE: _____

SIGNATURE: _____

WITNESS NAME / TITLE: _____

WITNESS SIGNATURE: _____

ADDRESS: _____

EMAIL: _____

TELEPHONE: _____

DATE: _____ SEAL:

Please refer to Appendix C: Bidder's Response Guide to ensure you include all necessary documentation with your bid submission

APPENDIX B: Bid Form

Submitted By: _____

To:

St. Clair Catholic District School Board
626-CP1916 Universal Washroom Project
St. Anne Catholic School, Blenheim, ON

B1. Bid Price

The Drawings, Specifications and other Contract Documents for this Project have been examined, as well as the premises and job site conditions affecting the work. The undersigned hereby offers to complete the work in accordance with the Contract Documents for the following bid price, except as defined below for HST:

_____ Dollars (\$ _____)

in Canadian funds EXCLUDING HST. HST will be added to the bid price.

In submitting this Bid, the undersigned recognizes and accepts the right of the Owner to accept any Bid, which is deemed the most advantageous to the Owner, (or any part thereof), at the price submitted, or to reject any or all Bids. Acceptance of the Bid and/or award of the contract is subject to the approval of the Board.

In the event that a discrepancy arises between the written bid price and the associated numerical price, the written bid price will be deemed to be correct.

B2. Harmonized Sales Tax (HST)

The bidder shall not include the applicable HST in the bid price. The successful contractor will indicate on each application for payment as a separate amount the appropriate HST the Owner is obliged to pay.

B3. Cash Allowances

1. Include a Stipulated Sum of Fifteen Thousand Dollars (\$15,000.00) to cover over the following items from which the Consultant shall direct payment for services, labour, and material.
 - a. Provisional Cash Allowance
 - b. Owner's Provisional Allowance
2. Include a Stipulated Sum of Ten Thousand Dollars (\$10,000.00) to cover costs associated with relocation of IT equipment completed by Owner's Vendor.

Time and Materials rates to be applied against Cash Allowance work. Final reconciliation will adjust the cash allowance as credit to the SCCDSB for unexpended amounts and extra to the contractor for over expenditure. The contractor shall mark-up sub-trade time and materials billing for this portion of work at 10% only.

B4. List of Subcontractors

Masonry	_____
Doors & Frames	_____
Gypsum Board & Acoustics	_____
Flooring (VCT)	_____
Flooring (Terrazzo)	_____

B5. Project Superintendent / Supervisor

The Owner requires the General Contractor provide a full time site supervisor for the duration of the project. A minimum of 5 years supervisory experience is required. List proposed personnel and their experience in the table below. Supervisory experience with firms other than the Bidder is acceptable to include on the list. The General Contractor shall indicate the person chosen in writing to the Owner within 5 days of contract award.

Name	Firm/Position	Qualifications/ Experience

APPENDIX C: Bidder's Response Guide

Each bid submission should be structured using only the criteria identified in this bid document.

1. A signed copy of APPENDIX A: Agreement of Terms **must** be included for your bid submission to be accepted
2. A completed copy of APPENDIX B: Bid Form **must** be included in your bid submission.
3. Proof of WSIB Coverage and proof of insurance **must** be included in your bid submission.
4. Bidders **must** provide one signed copy of the bid documents.
5. Supplemental material will not qualify as substitutes for direct responses to the bid's requirements, except for specifically requested material.
6. The successful contractor must be prequalified under the contracted services program before an award is made.
7. The work shall conform to the latest standards and codes listed in the Ontario School Code, National School Code, and all applicable provincial and municipal codes as of the date of this project in case of conflict or discrepancy; the most stringent requirement shall apply.
8. Contractor shall apply for and obtain all required SCCDSB or Provincial licenses as necessary.
9. Pay all fees and obtain all permits (excluding building permit). Provide authorities with plans and information for acceptance certificates. Provide inspection certificates as evidence that work conforms to requirements of Authority having jurisdiction.



Tender 626-1916
Universal Washroom Project
St. Anne Catholic School
183 Snow Ave, Blenheim, ON

APPENDIX D: Scope of Work and Specifications

Section No.	Title	No of Pages
DIVISION 00 – PROCUREMENT & CONTRACTING REQUIREMENTS		
00 00 10	List of Contents	1
DIVISION 01 - GENERAL REQUIREMENTS		
00 80 00	Supplementary Conditions	8
00 90 10	Substitution Request Form	2
01 00 00	General Requirements	4
01 21 00	Allowances	1
01 23 20	Separate Prices	1
01 25 00	Contract Modifications	2
01 29 00	Payment Procedures	2
01 31 00	Project Management and Coordination	2
01 31 19	Project Meetings	1
01 32 16	Construction Schedule	2
01 33 00	Submittal Procedures	3
01 35 29	Health and Safety Requirements	2
01 35 43	Environmental Procedures	1
01 41 00	Regulatory Requirements	1
01 45 00	Quality Control	1
01 51 00	Temporary Utilities	2
01 52 00	Construction Facilities	1
01 56 00	Temporary Barriers and Enclosures	1
01 61 00	Common Product Requirements	3
01 71 00	Examination and Preparation	1
01 73 00	Execution	2
01 74 11	Cleaning	2
01 78 00	Closeout Procedures & Submittals	3
01 79 00	Demonstration & Training	1
DIVISION 02		
02 41 99	Demolition	2
DIVISION 03 - 05 NOT USED		
DIVISION 06 – WOOD, PLASTICS AND COMPOSITES		
06 10 00	Rough Carpentry	4
06 20 00	Finish Carpentry	3
DIVISION 07 – THERMAL AND MOISTURE PROTECTION		
07 21 16	Blanket Insulation	2
07 84 00	Fire Stopping and Smoke Seals	4
07 90 00	Joint Sealants	4
DIVISION 08 – OPENINGS		
08 11 00	Metal Doors and Frames	4
08 71 00	Finished Hardware	1
DIVISION 09 – FINISHES		
09 21 16	Gypsum Board Assemblies	4
09 22 16	Non-Structural Metal framing	3
09 51 90	Acoustic Ceiling System	2

Section No.	Title	No of Pages
09 65 99	Resilient Flooring	3
09 66 20	Epoxy Terrazzo	7
09 90 00	Painting	10
	DIVISION 10 - SPECIALTIES	
10 28 00	Washroom Accessories	2
	DIVISION 11 – 30 NOT USED	

END OF SECTION

The Standard Construction Document for Stipulated Price Contract, 2008 English version, consisting of the Agreement Between *Owner* and *Contractor*, Definitions, and General Conditions of the Stipulated Price Contract, Parts 1 to 12 inclusive, governing same is hereby made part of these *Contract Documents*, with the following amendments, additions and modifications for the above named Project. Where these amendments, additions, and modifications specifically reference a change to the Agreement, Definitions, or General Conditions, these amendments, additions and modifications shall govern.

1 **ARTICLE A-5 PAYMENT:**

- .1 Insert in Paragraph 5.1 "Ten Percent (10%)"
- .2 Insert in Paragraph 5.3 "Bank of Canada"

2 **ARTICLE A-6 RECEIPT OF AND ADDRESSES FOR NOTICES IN WRITING**

- .1 Delete Article A-6.1 and substitute new article 6.1:
 - 6.1 *Notices in Writing* between the parties or between them and the *Consultant* shall be considered to have been received by the addressee on the date of receipt if delivered by hand or by commercial courier or if sent during normal business hours by fax and addressed as set out below. Such *Notices in Writing* will be deemed to be received by the addressee on the next business day if sent by fax after normal business hours or if sent by overnight commercial courier. Such *Notices in Writing* will be deemed to be received by the addressee on the fifth *Working Day* following the date of mailing, if sent by pre-paid registered post, when addressed as set out below. An address for a party may be changed by *Notice in Writing* to the other party setting out the new address in accordance with this Article.

3 **ARTICLE A-7 LANGUAGE OF THE CONTRACT**

- .1 Refer to sentence 7.1, strike out "French"

4. **DEFINITIONS**

- .1 Add the following definition:
 - 27. **Submittals**
Submittals are documents or items required by the *Contract Documents* to be provided by the *Contractor*, such as:
 - *Shop Drawings*, samples, models, mock-ups to indicate details or characteristics, before the portion of the *Work* that they represent can be incorporated into the *Work*; and
 - As-built drawings and manuals to provide instructions to the operation and maintenance of the *Work*.

5. **PART 1 GENERAL PROVISIONS**

- .1 Where a General Condition or paragraph of the General Conditions of the Stipulated Price Contract is deleted by these Supplementary Conditions, the numbering of the remaining General Conditions or paragraphs shall remain unchanged, and the numbering of the deleted item will be retained, unused.

6. **GENERAL PROVISIONS**

- .1 Where a General Condition or paragraph of the General Conditions of the Stipulated Price Contract is deleted by these Supplementary Conditions, the numbering of the remaining General Conditions or paragraphs shall remain unchanged, and the numbering of the deleted item will be retained, unused.

7. GC 1.1 CONTRACT DOCUMENTS

- .1 Add to the end of subparagraph 1.1.2.2

Except where the *Consultant* shall be indemnified as a third party beneficiary as provided in subparagraphs 9.2.7.4, 9.5.3.4 and in 12.1.3.

- .2 Add new subparagraph 1.1.7.5:

1.1.7.5 In case of discrepancies, noted materials and annotations shall take precedence over graphic indications in the *Contract Documents*.

- .3 Delete paragraph 1.1.8 and substitute new paragraph 1.1.8:

1.1.8 The *Owner* shall provide the *contractor* digital copies (PDF format) of the *Contract Documents* and all administrative documents such as *Change Orders*, *Change Directives*, and *Supplemental Instructions*. All required hardcopies of the *Contract Documents* or part thereof including additional copies of administrative documents, shall be at the expense of the contractor.

8. GC 2.2 ROLE OF THE CONSULTANT

- .1 Add to the end of paragraph 2.2.9

The *Owner* and the *Contractor* shall waive any claims against the *Consultant* arising out of the making of such interpretations and findings made in accordance with paragraphs 2.2.7., 2.2.8. and 2.2.9.

- .2 Delete paragraph 2.2.14 and substitute new paragraph 2.2.14:

2.2.14 The *Consultant* will review and take appropriate action upon *Shop Drawings*, samples and other *Contractor's* submittals which are provided in accordance with the *Contract Documents*.

9. GC 2.4 DEFECTIVE WORK

- .1 Add new subparagraph 2.4.1.1

2.4.1.1 The *Contractor* shall rectify, in a manner acceptable to the *Owner* and the *Consultant*, all defective work and deficiencies throughout the *Work*, whether or not they are specifically identified by the *Consultant*.

- .2 Add new subparagraph 2.4.1.2

2.4.1.2 The *Contractor* shall prioritize the correction of any defective work which, in the sole discretion of the *Owner*, adversely affects the day to day operation of the *Owner*.

10. GC 3.1 CONTROL OF THE WORK

- .1 Add new paragraph 3.1.3

3.1.3 Prior to commencing individual procurement, fabrication and construction activities, the *Contractor* shall verify, at the *Place of the Work*, all relevant measurements and levels necessary for proper and complete fabrication, assembly and installation of the *Work* and shall further carefully compare such field measurements and conditions with the requirements of the *Contract Documents*. Where dimensions are not included or contradictions exist, or exact locations are not apparent, the *Contractor* shall immediately notify the *Consultant* in writing and obtain written instructions from the *Consultant* before proceeding with any part of the affected work.

11. GC 3.4 DOCUMENT REVIEW

.1 Delete paragraph 3.4.1 and substitute new paragraph 3.4.1

3.4.1 The *Contractor* shall review the *Contract Documents* and shall report promptly to the *Consultant* any error, inconsistency or omission the *Contractor* may discover. Such review by the *Contractor* shall comply with the standard of care described in paragraph 3.14.1 of the *Contract*. Except for its obligation to make such review and report the result, the *Contractor* does not assume any responsibility to the *Owner* or to the *Consultant* for the accuracy of the *Contract Documents*. The *Contractor* shall not be liable for damage or costs resulting from such errors, inconsistencies, or omissions in the *Contract Documents*, which the *Contractor* could not reasonably have discovered. If the *Contractor* does discover any error, inconsistency or omission in the *Contract Documents*, the *Contractor* shall not proceed with the work affected until the *Contractor* has received corrected or missing information from the *Consultant*.

12. GC 3.7 SUBCONTRACTORS AND SUPPLIERS

.1 Add new paragraph 3.7.7

3.7.7 After signing of the *Contract*, no deviation from the list of *Subcontractors* or *Suppliers* shall be made during the progress of the *Work* of the *Contract* without the *Owner's* written permission.

13. GC 3.8 LABOUR AND PRODUCTS

.1 Add new paragraph 3.8.4

3.8.4 The *Contractor* is responsible for the safe on-site storage of *Products* and their protection (including *Products* supplied by the *Owner* and other contractors to be installed under the *Contract*) in such ways as to avoid dangerous conditions or contamination to the *Products* or other persons or property and in locations at the *Place of the Work* to the satisfaction of the *Owner* and the *Consultant*. The *Owner* shall provide all relevant information on the *Products* to be supplied by the *Owner*.

14. GC 3.10 SHOP DRAWINGS

.1 Add the words "AND OTHER SUBMITTALS" to the Title after SHOP DRAWINGS.

.2 Add "and *Submittals*" after the words "*Shop Drawings*" in paragraphs 3.10.1, 3.10.2, 3.10.4, 3.10.7, 3.10.8, 3.10.8.2, 3.10.9, 3.10.10, 3.10.11, and 3.10.12.

.3 Delete paragraph 3.10.3 and substitute new paragraph 3.10.3

3.10.3 Prior to the first application for payment, the *Contractor* and the *Consultant* shall jointly prepare a schedule of the dates for submission and return of *Shop Drawings* and any *Submittals*.

.4 Delete paragraph 3.10.12 and substitute new paragraph 3.10.12

3.10.12 The *Consultant* will review and return *Shop Drawings* in accordance with the schedule agreed upon, or, in the absence of such schedule, within 10 working days or such longer period as may be reasonably required.

15. **PART 3 EXECUTION OF THE WORK**

.1 Add new General Condition 3.14 PERFORMANCE BY CONTRACTOR

.2 Add new paragraph 3.14.1

3.14.1 In performing its services and obligations under the *Contract*, the *Contractor* shall exercise a standard of care, skill and diligence that would normally be provided by an experienced and prudent contractor supplying similar services for similar projects. The *Contractor* acknowledges and agrees that throughout the *Contract*, the *Contractor's* obligations, duties and responsibilities shall be interpreted in accordance with this standard. The *Contractor* shall exercise the same standard of due care and diligence in respect of any *Products*, personnel, or procedures which it may recommend to the *Owner*.

.3 Add new paragraph 3.14.2

3.14.2 The *Contractor* further represents, covenants and warrants to the *Owner* that:

- .1 The personnel it assigns to the *Project* are appropriately experienced;
- .2 It has a sufficient staff of qualified and competent personnel to replace its designated supervisor and project manager, subject to the *Owner's* approval, in the event of death, incapacity, removal or resignation.

16. **GC 4.1 CASH ALLOWANCES**

.1 Delete paragraph 4.1.4 substitute new paragraph 4.1.4

4.1.4 Where costs under a cash allowance exceed the amount of the allowance, unexpended amounts from other cash allowances shall be reallocated at the *Consultant's* direction to cover the shortfall.

.2 Delete paragraph 4.1.5 substitute new paragraph 4.1.5:

4.1.5. The net amount of any unexpended cash allowances, after providing for any reallocations as contemplated in paragraph 4.1.4, shall be deducted from the *Contract Price* by *Change Order*.

.3 Delete paragraph 4.1.7 and substitute new paragraph 4.1.7.

4.1.7 At the commencement of the *Work*, the *Contractor* shall prepare for the review and acceptance of the *Owner* and the *Consultant*, a schedule indicating the times, within the construction schedule referred to in GC 3.5, that items called for under cash allowances and items that are specified to be *Owner* purchased and *Contractor* installed or hooked up are required at the site to avoid delaying the progress of the *Work*.

.4 Add new paragraph 4.1.8:

4.1.8 The *Owner* reserves the right to call, or to have the *Contractor* call, for competitive bids for portions of the *Work*, to be paid for from cash allowances.

17. GC 6.2 CHANGE ORDER

.1 Add new paragraph 6.2.3

6.2.3 The value of changes to the *Work* shall be determined by one of the following agreed upon methods:

(A) Estimate and acceptance of itemized lump sum for additional *Work* with overhead and profit applied as a percentage as listed below:

.1 10% overhead and 5% profit for net cost of *Work* done by Contractors own forces

.2 5% overhead and 5% profit for net cost *Work* done by *Subcontractors*

.3 0% overhead and profit on credits

(B) Unit prices as set out in the contract or subsequently agreed upon, with adjustments to the *Contract Price* based on net quantity difference from original quantity. Overhead and profit applied as a percentage as listed below:

.1 10% overhead and 5% profit for net cost of *Work* done by Contractors own forces

.2 5% overhead and 5% profit for net cost *Work* done by *Subcontractors*

.3 0% overhead and profit on credits

18. GC 6.4 CONCEALED OR UNKNOWN CONDITIONS

.1 Add new paragraph 6.4.5

6.4.5 The *Contractor* confirms that, prior to bidding the *Project*, it carefully investigated the *Place of the Work* and applied to that investigation the degree of care and skill described in paragraph 3.14.1, given the amount of time provided between the issue of the bid documents and the actual closing of bids, the degree of access provided to the *Contractor* prior to submission of bid, and the sufficiency and completeness of the information provided by the *Owner*. The *Contractor* is not entitled to compensation or to an extension of the *Contract Time* for conditions which could reasonably have been ascertained by the *Contractor* by such careful investigation undertaken prior to the submission of the bid.

19. GC 6.5 DELAYS

.1 Delete the period at the end of paragraph 6.5.1, and substitute the following words:

“, but excluding any consequential, indirect or special damages.”

.2 Add new subparagraph 6.5.6.

6.5.6 If the *Contractor* is delayed in the performance of the *Work* by an act or omission of the *Contractor* or anyone employed or engaged by the *Contractor* directly or indirectly, or by any cause within the *Contractor's* control, then the *Contract Time* shall be extended for such reasonable time as the *Consultant* may decide in consultation with the *Contractor*. The *Owner* shall be reimbursed by the *Contractor* for all reasonable costs incurred by the *Owner* as the result of such delay, including all services required by the *Owner* from the *Consultant* as a result of such delay by the *Contractor* and, in particular, the cost of the *Consultant's* services during the period between the date of *Substantial Performance of the Work* stated in Article A-1 herein as the same may be extended through the provisions of these General Conditions and any later, actual date of *Substantial Performance of the Work* achieved by the *Contractor*.

20. GC 6.6 CLAIMS FOR A CHANGE IN CONTRACT PRICE

.1 In paragraph 6.6.5, Add the words “as noted in paragraph 6.6.3” after the words “of the claim” and add the words “and the *Consultant*”, at the end of paragraph 6.6.5.

21. GC 8.2 NEGOTIATION, MEDIATION AND ARBITRATION

.1 Add new paragraph 8.2.9

- 8.2.9 Within five days of receipt of the notice of arbitration by the responding party under paragraph 8.2.6, the *Owner* and the *Contractor* shall give the *Consultant* a written notice containing:
- a) a copy of the notice of arbitration
 - b) a copy of supplementary conditions 8.2.9 to 8.2.14 of this *Contract*, and;
 - c) any claims or issues which the *Contractor* or the *Owner*, as the case may be, wishes to raise in relation to the *Consultant* arising out of the issues in dispute in the arbitration

.2 Add new paragraph 8.2.10

- 8.2.10 The *Owner* and the *Contractor* agree that the *Consultant* may elect, within ten days of receipt of the notice under paragraph 8.2.9, to become a full party to the arbitration under paragraph 8.2.6 if the *Consultant*:
- a) has a vested or contingent financial interest in the outcome of the arbitration;
 - b) gives the notice of election to the *Owner* and the *Contractor* before the arbitrator is appointed;
 - c) agrees to be a party to the arbitration within the meaning of the rules referred to in paragraph 8.2.6, and,
 - d) agrees to be bound by the arbitral award made in the arbitration.

.3 Add new paragraph 8.2.11

- 8.2.11 If an election is made under paragraph 8.2.10, the *Consultant* may participate in the appointment of the arbitrator and, notwithstanding the rules referred to in paragraph 8.2.6, the time period for reaching agreement on the appointment of the arbitrator shall begin to run from the date the respondent receives a copy of the notice of arbitration.

.4 Add new paragraph 8.2.12

- 8.2.12 The arbitrator in the arbitration in which the *Consultant* has elected under paragraph 8.2.10 to become a full party may:
- a) on application of the *Owner* or the *Contractor*, determine whether the *Consultant* has satisfied the requirements of paragraph 8.2.10, and;
 - b) make any procedural order considered necessary to facilitate the addition of the *Consultant* as a party to the arbitration.

.5 Add new paragraph 8.2.13

- 8.2.13 The provisions of paragraph 8.2.9 shall apply mutatis mutandis to written notice to be given by the *Consultant* to any sub-consultant;

.6 Add new paragraph 8.2.14

- 8.2.14 In the event of notice of arbitration given by the *Consultant* to a sub-consultant, the sub-consultant is not entitled to any election with respect to the proceeding as outlined in 8.2.10, and is deemed to be bound by the arbitration proceeding.

22. **GC 9.1 PROTECTION OF WORK AND PROPERTY**
- .1 Delete subparagraph 9.1.1.1 and substitute new subparagraph 9.1.1.1
- 9.1.1.1 Errors in the *Contract Documents* which the *Contractor* could not have discovered applying the standard of care described in paragraph 3.14.1;
- .2 Delete paragraph 9.1.2 and substitute new paragraph 9.1.2
- 9.1.2 Before commencing any *Work*, the *Contractor* shall determine the locations of all underground utilities and structures indicated in the *Contract Documents*, or that are discoverable by applying to an inspection of the *Place of the Work* the degree of care and skill described in paragraph 3.14.1.
23. **GC 9.2 TOXIC AND HAZARDOUS SUBSTANCES**
- .1 Add to paragraph 9.2.6 after the word "responsible", the following new words:
- or whether any toxic or hazardous substances or materials already at the *Place of the Work* (and which were then harmless or stored, contained or otherwise dealt with in accordance with legal and regulatory requirements) were dealt with by the *Contractor* or anyone for whom the *Contractor* is responsible in a manner which does not comply with legal and regulatory requirements, or which threatens human health and safety or the environment, or material damage to the property of the *Owner* or others,
- .2 Add "and the *Consultant*" after the word "*Contractor*" in subparagraph 9.2.7.4.
- .3 Add to paragraph 9.2.8 after the word "responsible", the following new words:
- or that any toxic or hazardous substances or materials already at the *Place of the Work* (and which were then harmless or stored, contained or otherwise dealt with in accordance with legal and regulatory requirements) were dealt with by the *Contractor* or anyone for whom the *Contractor* is responsible in a manner which does not comply with legal and regulatory requirements, or which threatens human health and safety or the environment, or material damage to the property of the *Owner* or others,
24. **GC 9.5 MOULD**
- .1 Add "and the *Consultant*" after "*Contractor*" in subparagraph 9.5.3.4.
25. **GC 10.1 TAXES AND DUTIES**
- .1 Add new paragraph 10.1.3
- 10.1.3 The *Contractor's* overhead and profit shall not be included on extras or credits resulting from changes in taxes and duties.
26. **GC 10.2 LAWS, NOTICES, PERMITS, AND FEES**
- .1 Delete paragraph 10.2.2 and substitute new paragraph 10.2.2
- 10.2.2 "The Owner shall obtain and pay for zoning revisions, permanent easements and rights of servitude. The Contractor shall be responsible for all permits, including the Building Permit, licenses, damage and other deposits, or certificates necessary for the performance of the Work which were in force at the date of bid closing.
- .2 Delete from the first line of paragraph 10.2.5 the word, "The" and substitute the words: "Subject to paragraph 3.14.1, the".

27. 11.2 CONTRACT SECURITY

.1 Delete paragraph 11.2.1 and substitute new paragraph 11.2.1

11.2.1 The *Contractor* shall provide to the *Owner* the following Bonds:

- .1 A Performance Bond in the amount of Fifty percent (50%) of the total *Contract* amount covering the performance of the *Contract*, *including the requirements of GC 12.3 WARRANTY*
- .2 A Labour and Materials Bond in the amount of Fifty Percent (50%) of the Total Contract Amount.

The *Contractor* shall deliver the original bonds to the *Owner* within ten (10) days of receipt by the *Contractor* of the *Owner's* written acceptance of the Bid.

.2 Add paragraph 11.2.3

11.2.3 The premiums for such bonds shall be included in the *Contract Price*.

28. GC 12.1 INDEMNIFICATION

.1 Add new subparagraph 12.1.1.3.

12.1.1.3 The *Contractor* shall indemnify and hold harmless the *Consultant*, its agents and employees from and against claims, demands, losses, costs, damages, actions, suits, or proceedings by third parties that arise out of, or are attributable to, the *Contractor's* performance of the *Contract*, provided such claims are attributable to bodily injury, sickness, disease, or death, or to injury to or destruction of tangible property, and caused by negligent acts or omissions of the *Contractor* or anyone for whose acts the *Contractor* may be liable, and made in writing within a period of 6 years from the date of *Substantial Performance of the Work* as set out in the certificate of *Substantial Performance of the Work*, or within such shorter such period as may be prescribed by any limitation statute or the province or territory of the *Place of Work*.

29. GC 12.3 WARRANTY

.1 Delete from the first line of paragraph 12.3.2 the word, "The" and substitute the words: "Subject to paragraph 3.14.1, the".

END OF SECTION

SUBSTITUTION REQUEST FORM

- Contractor Company _____
- Sub Trade
- Supplier | Manufacturer Date _____

Bidder hereby requests acceptance of the following product or system as a substitution in accordance with provisions of Section 00 21 13 - Instructions to Bidders, and Section 00 90 00 "Substitution Procedures."

1. SPECIFIED PRODUCT OR SYSTEM

Substitution request for: _____

Specification Section No.: _____ Article | Paragraph _____

2. REASON FOR SUBSTITUTION REQUEST

PROPOSED PRODUCT

- Will reduce construction time
- Will result in cost savings
- Requested Alternative
- Is for subcontractors convenience
- Other: _____

3. PROPOSED SUBSTITUTION

Manufacturer: _____ Phone Number: _____

Product Name: _____ Model | Series: _____

Installer: _____ Phone Number: _____

Warranty: _____ Additional Info: _____

4. MANDATORY SUPPORTING DATA

- Drawings, specifications, product data, performance data, test data, and any other necessary information to facilitate review of the Substitution Request is attached
- Sample Attached

5. EFFECT OF SUBSTITUTION

Proposed substitution effects other work or trades: No Yes (if yes, explain)

Proposed substitution requires dimensional revisions or redesign of architectural, civil, structural, mechanical, electrical or other work: No Yes (if yes, explain)

6. STATEMENT OF CONFORMANCE OF REQUEST TO CONTRACT REQUIREMENTS

Submitting Contractor has investigated the proposed substitution and hereby represent that:

- A. They have personally investigated the proposed substitution and believe that it is equal to or superior in all respects to specified product, except as stated above;
- B. The proposed substitution is in compliance with applicable codes and ordinances;
- C. The proposed substitution will provide same warranty as specified for specified product;
- D. They will coordinate the incorporation of the proposed substitution into the Work, and will include modifications to the Work as required to fully integrate the substitution;
- E. They waive all future claims for added cost or time to the Contract related to the substitution, or that become known after substitution is accepted.
- F. The Architect's approval, if granted, will be based upon data submitted with this request and opinion, knowledge, information, and belief of the Architect at the time decision is rendered and Addendum is issued; and that Architect's approval therefore is interim in nature and subject to reevaluation and reconsideration as additional data, materials, workmanship, and coordination with other work are observed and reviewed.

Bidding Contractor: _____
(Name of Contractor)

Date: _____ By: _____

End of Document

Part 1 General

1.1 WORK COVERED BY CONTRACT DOCUMENTS

- .1 Work to complete a new universal washroom and renovations at St. Anne Catholic School and further identified as ROA studio Inc. Project ID 19-012.

1.2 CONTRACT METHOD

- .1 Construct Work under single, stipulated price contract, CCDC2-2008

1.3 DOCUMENTS REQUIRED

- .1 Maintain at job site, one copy each document as follows:
 - .1 Contract Drawings.
 - .2 Specifications.
 - .3 Addenda.
 - .4 Reviewed Shop Drawings.
 - .5 List of Outstanding Shop Drawings.
 - .6 Change Orders.
 - .7 Other Modifications to Contract.
 - .8 Field Test Reports.
 - .9 Copy of Approved Work Schedule.
 - .10 Health and Safety Plan and Other Safety Related Documents.
 - .11 Other documents as specified

1.4 PERMITS

- .1 The Contractor shall apply and pay for all permits, including the Building Permit, licenses, damage and other deposits, or certificates necessary for the performance of the Work which were in force at the date of bid closing.

1.5 CONTRACTOR USE OF PREMISES

- .1 Limit access of construction personnel to areas of Work. Ensure construction personnel do not use occupied areas of the existing building as access to the work areas, except where prearranged with Owner.
- .2 Prohibit use of washroom and services in building by construction personnel, except where prearranged with Owner.
- .3 Smoking is prohibited everywhere on the property.
- .4 Secure work area by methods compatible with the total security established for the building.
- .5 Contractor's forces, tradesmen, workers, suppliers of subcontractors employed directly or indirectly by the Contractor will be allowed to park their vehicles in designated areas.
- .6 Obtain and pay for use of additional storage or work areas needed for operations under this Contract.

- .7 At completion of operations condition of existing work: equal to or better than that which existed before new work started.

1.6 OWNER OCCUPANCY

- .1 Portion of building not under construction will be occupied during entire construction period.

1.7 EXISTING SERVICES

- .1 Ensure that existing services are not damaged during demolition and construction. Immediately cut off and cap concealed services uncovered during work by qualified mechanical and electrical workers.
- .2 Relocate mechanical and electrical services exposed during alteration work.
- .3 Should existing services be accidentally uncovered and disrupted, notify Owner and make complete restoration immediately, and provide adequate protection to avoid further disruption until alternative means of providing permanent continuation of the services can be made.
 - .1 Rectification for work specified in the above shall be made by the Contractor at no additional cost to the Owner, if such work could have been foreseen and which has been caused by lack of proper care and protection.
 - .2 If accidental disruption is made and could not have been foreseen, the Contractor shall advise Consultant and Owner of the commencement, duration and termination dates of this work; keep a record of work hours, number of workers, tools, equipment rentals, quantities of material used, mileage, etc. to present with claim.
- .4 Unless otherwise specified, restore services on which work is performed to original condition.

1.8 SAFETY AND SECURITY DURING CONSTRUCTION IN NEAR EXISTING BUILDINGS

- .1 Building Exits: All exits, including stairways and exterior doors to the outside, serving the existing building shall be maintained.
- .2 Fire Department Access: Construction activities shall not obstruct the access roadways designated for fire department equipment.

1.9 PROJECT MEETINGS

- .1 Attend project meetings.
- .2 Representatives of Contractor, Subcontractor and suppliers attending meetings will be qualified and authorized to act on behalf of party each represents.
- .3 Consultant will distribute written notice of meetings, prepare agenda, record minutes and distribute copies of minutes.

1.10 HEALTH & SAFETY

- .1 The Owner is firmly committed to Corporate Health & Safety.
- .2 The Contractor shall have Corporate Health and Safety Policies and Procedures as required in the Occupational Health and Safety Act and Regulations for Construction Projects, R.S.O. 1980.
- .3 To provide a safe and healthy work environment the Contractor warrants and confirms:

- .1 that it has a written Health and Safety policy in place in accordance with the Occupational Health and Safety Act, R.S.O. 1990;
 - .2 that the appropriate instruction and training has been provided to the employees in accordance with the Occupational Health and Safety Act, R.S.O. 1990 and
 - .3 that the works shall be undertaken in strict accordance with all applicable provisions of the Occupational Health and Safety Act.
Note: In cases of discrepancy in document content, the Policy or Procedure providing the highest level of Health and Safety shall govern.
 - .4 The Bidder's documentation and commitment to Health & Safety will be a requirement of this contract.
- .4 Submit copies of incident and accident reports.

1.11 FILING OF NOTICE

- .1 File Notice of Project with Ontario Ministry of Labour prior to beginning of Work.

1.12 REGULATORY REQUIREMENTS

- .1 References and Codes
 - .1 Perform Work in accordance with the Ontario Building Code (OBC) including amendments up to tender closing date and other codes of provincial or local application provided that in case of conflict or discrepancy, more stringent requirements apply.
 - .2 Meet or exceed requirements of:
 - .1 Contract documents.
 - .2 Specified standards, codes and referenced documents.

1.13 INSPECTION

- .1 Allow Owner and Consultant access to Work. If part of Work is in preparation at locations other than Place of Work, allow access to such Work whenever it is in progress.
- .2 If Contractor covers or permits to be covered Work that has been designated for special tests, inspections or approvals before such is made, uncover such Work, have inspections or tests satisfactorily completed and make good such Work.
- .3 Consultant will order part of Work to be examined if Work is suspected to be not in accordance with Contract Documents. If, upon examination such work is found not in accordance with Contract Documents, correct such Work and pay cost of examination and correction. If such Work is found in accordance with Contract Documents, Owner shall pay cost of examination and replacement.

1.14 REJECTED WORK

- .1 Remove defective Work, whether result of poor workmanship, use of defective products or damage and whether incorporated in Work or not, which has been rejected by Consultant as failing to conform to Contract Documents. Replace or re-execute in accordance with Contract Documents.
- .2 Make good other Contractor's work damaged by such removals or replacements promptly.
- .3 If in opinion of Consultant it is not expedient to correct defective Work or Work not performed in accordance with Contract Documents, Owner will deduct from Contract

Price difference in value between Work performed and that called for by Contract Documents, amount of which will be determined by Consultant.

1.15 PROJECT CLEANLINESS

- .1 Maintain Work in tidy condition, free from accumulation of waste products and debris.
- .2 Remove waste materials from site at daily regularly scheduled times. Do not burn waste materials on site.
- .3 Make arrangements with and obtain permits from authorities having jurisdiction for disposal of waste and debris.
- .5 Provide on-site containers for collection of waste materials and debris.
- .6 Provide and use marked separate bins for recycling.
- .7 Dispose of waste materials and debris off site.
- .8 Protect existing materials and equipment from damage during construction. Provide polyethylene cover over any furniture and equipment remaining in work area in order to minimize damage from construction dirt and debris.
- .9 Clean interior areas prior to start of finishing work, and maintain areas free of dust and other contaminants during finishing operations.
- .10 Store volatile waste in covered metal containers, and remove from premises at end of each working day.
- .11 Provide adequate ventilation during use of volatile or noxious substances. Use of building ventilation systems is not permitted for this purpose.
- .12 Use only cleaning materials recommended by manufacturer of surface to be cleaned, and as recommended by cleaning material manufacturer.
- .13 Schedule cleaning operations so that resulting dust, debris and other contaminants will not fall on wet, newly painted surfaces nor contaminate building systems.

Part 2 Products

2.1 NOT USED

- .1 Not used.

Part 3 Execution

3.1 NOT USED

- .1 Not used.

END OF SECTION

Part 1

General

- .1 Include in Contract Price specified cash allowances.
- .2 Cash allowances, unless otherwise specified, cover net cost to Contractor of services, products, construction machinery and equipment, freight, handling, unloading, storage installation and other authorized expenses incurred in performing Work.
- .3 Contract Price, and not cash allowance, includes Contractor's overhead and profit in connection with such cash allowance.
- .4 Contract Price, and not cash allowance, includes HST payable in connection with such cash allowance.
- .5 Contract Price will be adjusted by written order to provide for excess or deficit to each cash allowance.
- .6 If overhead and profit to the Contract are determined by means not identified in the Contract Documents, edit the following paragraph to suit conditions accordingly.
- .7 Where costs under a cash allowance exceed amount of allowance, Contractor will be compensated for excess incurred and substantiated plus allowance for overhead and profit as set out in Contract Documents.
- .8 Include progress payments on accounts of work authorized under cash allowances in Consultant's monthly certificate for payment.
- .8 Authorization to Disburse Allowances: Expenditures from Allowances included in the contract must be authorized in writing by the Consultant, the Owner and the Contractor and issued as a Cash Allowance Disbursement Authorization (CADA).
- .9 Include the following cash allowances in the Stipulated Price.
 - .1 Cash Allowance: Fifteen Thousand Dollars (\$15,000.00) to cover the following items from which the Consultant shall direct payment for services, labour, and material.
 - .1 Provisional Cash Allowance
 - .2 Owner's Provisional Allowance
 - .2 IT Relocation Allowance: Ten Thousand Dollars (\$10,000.00) to cover the cost to relocate the IT equipment by Owner's preferred vendor. Preferred Vendor is Wiring Solutions Inc.

PART 2 – PRODUCTS – Not Used

PART 3 – EXECUTION – Not used

End of Section

Part 1 General

1.1 SECTION INCLUDES

- .1 Contract modification procedures.

1.2 VARIATIONS

- .1 Once a Proposed Change has been issued by the Consultant, it shall be the responsibility of the Contractor to ensure that no work is carried out that may increase the cost of the variation contemplated until a decision on the acceptance or rejection of the Proposed Change is made, and a Change Order has been issued.
- .2 The Consultant will assess the cost of each change before issuing a Change Order. Assist the Consultant with this task by quoting all variations in a complete manner listing:
 - quantity of each material,
 - unit cost of each material,
 - man hours involved,
 - cost per hour,
 - Subcontractor quotations,
 - impact on Project schedule and completion, and
 - overhead and profit fees.
- .3 The Consultant may require further quotations in order to show a breakdown of costs.
- .4 The Owner and the Consultant will not be responsible for delays to the Work resulting from late, incomplete or inadequately broken down valuations submitted by the Contractor.
- .5 Minor variations may be made in the project from time to time as approved by the Consultant. Such alterations or adjustments shall not constitute a change in cost unless a Proposed Change is made at the time. No extra will be contemplated except where a clear indication is made that extra payment is claimed, in which case a Change Order will be issued by the Consultant. Unless this procedure is followed, no claims for additional amounts will be allowed.
- .6 Changes in the Work will be subject to the allowable mark-up as follows:
 - .1 The value of changes in the Work shall be determined by one of the following methods as agreed to by the Contractor and the Owner:
 - .1 estimate and acceptance in a lump sum, substantiated by an itemized Cost Breakdown satisfactory to the Owner with overhead and profit applied at the percentages listed below.
 - .2 The itemized "Cost Breakdown" shall include all net costs to the Contractor excluding his overhead and profit. "Overhead and Profit" shall be calculated at the rates listed below. "Overhead" shall include the following costs to the Contractor:
 - .1 The Contractor's head office and site office expenses, including stationery, postage and other office supplies.
 - .2 The salaries of superintendents, engineers, timekeepers, accountants, clerks, watchmen, and similar personnel employed directly on the Work. Wages on workers and foreman and the assessments thereon for Worker's Compensation, Unemployment Insurance, vacation with pay, and Canada Pension payments, etc., are part of the actual cost.
 - .3 Use of temporary offices, sheds, etc., including cost of telephone, light, power, water and heat used therein.
 - .4 Transportation and overnight room expenses for out of town labour, if local labour is not available.
 - .5 Insurance and bond premiums.
 - .6 Licenses and permits, except when these are special for a particular item of work.

- .7 Printing charges for Proposed Changes, Change Orders and Drawings for Contractor and Subcontractors use in the work. (Consultant will provide one copy of change notice documentation and in the event of re-issue of full size drawings will provide one copy of drawings.)
- .3 On work done by the General Contractor's own forces, a maximum of 5% overhead plus 5% profit shall be the percentage Fee applied to the net cost.
- .4 On work done by Subcontractors, the General Contractor shall charge a maximum of 5% as the percentage Fee applied to the net cost.
- .5 No mark-ups on credits, for overhead and profit, will be permitted.
- .6 Subcontractors - on work done by the Subcontractor's own forces, a maximum of 5% overhead plus 5% profit shall be the percentage Fee applied to the net cost

PART 2 – PRODUCTS – Not Used

PART 3 – EXECUTION – Not used

END OF SECTION

Part 1

General

1.1 REFERENCES

- .1 Owner/Contractor Agreement; CCDC2-2008, as Amended.

1.2 APPLICATIONS FOR PROGRESS PAYMENT

- .1 Make applications for payment on account monthly as Work progresses.
- .2 Date applications for payment last day of agreed monthly payment period and ensure amount claimed is for value, proportionate to amount of Contract, of Work performed and Products delivered to Place of Work at that date.
- .3 Submit to Consultant, at least 14 days before first application for payment. Schedule of values for parts of Work, aggregating total amount of Contract Price, to facilitate evaluation of applications for payment.

1.3 SCHEDULE OF VALUES

- .1 Provide schedule of values supported by evidence as Consultant may reasonably direct and when accepted by Consultant, be used as basis for applications for payment.
- .2 Include statement based on schedule of values with each application for payment.
- .3 Support claims for products delivered to Place of Work but not yet incorporated into Work by such evidence as Consultant may reasonably require to establish value and delivery of products.
- .4 Schedule of Values to include a value of One Thousand Dollars (\$1,000.00) for project close-out documents (as-builts and maintenance manuals). Payments for close-out documents will be released after documents are submitted and approved by the consultants.

1.4 PROGRESS PAYMENT

- .1 Consultant will issue to Owner, no later than 10 days after receipt of an application for payment, certificate for payment in amount applied for or in such other amount as Consultant determines to be due.

1.5 SUBSTANTIAL PERFORMANCE OF WORK

- .1 Apply for a review by Consultant to establish Substantial Performance of Work when Work is substantially performed if permitted by lien legislation applicable to Place of Work
- .2 No later than 10 days after receipt of list and application, Consultant will review Work to verify validity of application, and no later than 7 days after completing review, will notify Contractor if Work or designated portion of Work is substantially performed.
- .3 Consultant will state date of Substantial Performance of Work in certificate.
- .4 Immediately following issuance of certificate of Substantial Performance of Work, in consultation with Consultant, establish reasonable date for finishing Work.

1.6 PAYMENT OF HOLDBACK UPON SUBSTANTIAL PERFORMANCE OF WORK

- .1 After issuance of certificate of Substantial Performance of Work:
 - .1 Submit application for payment of holdback amount.
 - .2 Submit sworn statement that accounts for labour, subcontracts, products, construction machinery and equipment, and other indebtedness which may have been incurred in Substantial Performance of Work and for which Owner might in be held responsible have been paid in full, except for amounts properly retained as holdback or as identified amount in dispute.
- .2 After receipt of application for payment and sworn statement, Consultant will issue certificate for payment of holdback amount.

- .3 Amount authorized by certificate for payment of holdback amount is due and payable on day following expiration of holdback period stipulated in lien legislation applicable to Place of Work. Owner may retain out of holdback amount sums required by law to satisfy liens against Work.

1.7 FINAL PAYMENT

- .1 Submit application for final payment when Work is completed.
- .2 Consultant will, no later than 10 days after receipt of application for final payment, review Work to verify validity of application. Consultant will give notification that application is valid or give reasons why it is not valid, no later than 7 days after reviewing Work.
- .3 Consultant will issue final certificate for payment when application for final payment is found valid.

PART 2 – PRODUCTS – Not Used

PART 3 – EXECUTION – Not used

End Of Section

Part 1

General

1.1

ADMINISTRATIVE

- .1 Security and control of Project is the responsibility of the Contractor.
- .2 Contractor responsible as to which trade provides required materials or articles and work.
- .3 Contractor responsible for the coordination of all building components, materials and systems and the work of all subcontractors. The contractor will provide field drawings to coordinate the various parts of the work prior to commencement of work.

1.2

RELATED MECHANICAL AND ELECTRICAL WORK

- .1 Maintenance in the operation of any existing mechanical and electrical services is essential. All shut-downs are to be minimal and arrangements for their scheduling shall to be coordinated with Owner and Consultant. Time frame for notice of shutdown to be coordinated to owner prior to commencement of work.
- .2 Coordination of the installation of systems specified in Structural, Mechanical and electrical divisions including the interrelating operation and functioning between components of a system and between systems, is the responsibility of those performing the Work of Structural, Mechanical and Electrical divisions with final coordination the responsibility of the Contractor.
- .3 Conceal pipes, ducts, control systems and electrical distribution systems within wall, floor and ceiling construction except where indicated otherwise.
- .4 Ensure that pipes, conduit, wires, vents, regulators, meters and similar Project service installations are located in inconspicuous locations. If not indicated on Drawings, verify location of service installations with Consultant before commencing installation. Provide field drawings to the Consultant prior to any installation.

1.3

PRODUCT DELIVERY, STORAGE AND HANDLING

- .1 Schedule delivery of products, and provide delivery access and unloading areas.
- .2 Provide areas for storage of products and construction equipment to meet specified requirements, and to ensure a minimum of interference with progress of the Work and relocations.
- .3 All material, equipment and fixtures to be delivered, stored and handled as per manufacturer's written instructions.

1.4

JOB CONDITIONS

- .1 Ensure that conditions within the building are maintained. Ensure that protection of adjacent property and the Work is adequately provided for and maintained to meet specified requirements.

1.5

COORDINATION

- .1 Review Contract Documents and advise the Consultant of possible conflicts between parts of the Work before preparation of shop drawings, ordering of products or commencement of affected Work.
- .2 Coordinate all Work in each area and Work on which subsequent Work depends to facilitate mutual progress, and to prevent conflict between parts of the Work.
- .3 Ensure that each Section, before commencing its Work, knows requirements for subsequent Work and that each Section is assisted in the execution of its preparatory Work by Sections whose Work depends upon it.
- .4 Ensure that setting drawings, templates, and all other information necessary for the location and installation of materials, holes, sleeves, inserts, anchors, accessories, fastenings, connections, and access panels are provided by each Section whose Work

requires cooperative location and installation by other Sections, and that such information is communicated to the applicable installer.

1.6

CUTTING AND PATCHING

- .1 Before cutting, drilling, or sleeving structural load-bearing elements, obtain approval of location and methods.
- .2 Cut and drill with true smooth edges and to minimum suitable tolerances.
- .3 Fit construction tightly to ducts, pipes and conduits to stop air movement completely. The Section performing Work that penetrates a fire, air, vapour, moisture, thermal or acoustic separation of the building shall pack voids tightly with rock wool; seal air, vapour and moisture barriers; and caulk joints as may be required to ensure that no air movement through the penetration is possible. Where cutting and chasing reduces wall thickness, reinforce wall as required.
- .4 Replace, and otherwise make good, damaged work.
Make patches invisible in final assembly within physical limitations of materials as approved by Consultant.

PART 2 – PRODUCTS – Not Used

PART 3 – EXECUTION – Not used

End Of Section

Part 1 General

1.1 ADMINISTRATIVE

- .1 Schedule project meetings throughout the progress of the work, every other week.
- .2 Provide physical space and make arrangements for meetings.
- .3 Attend meetings.
- .4 Representative of Contractor, Subcontractor and suppliers attending meetings will be qualified and authorized to act on behalf of party each represents.
- .5 Consultant will distribute written notice of meetings, prepare agenda, record minutes and distribute copies of minutes.

1.2 PRECONSTRUCTION MEETING

- .1 Within 15 days after award of Contract, request a meeting of parties in contract to discuss and resolve administrative procedures and responsibilities.
- .2 Client Representatives, Consultant, Contractor, Major Subcontractors and site supervisor shall be in attendance.
- .3 Establish time and location of meeting and notify parties concerned.
- .4 Consultant to provide agenda.
- .5 Contractor to have available prior to meeting, construction schedule, Schedule of Values and all contract security.

1.3 PROGRESS MEETINGS

- .1 During course of Work schedule and attend progress meetings.
- .2 Contractor, major Subcontractors involved in Work, Consultant and Owner are to be in attendance.
- .3 Contractor to have available prior to meeting, construction schedule and schedule of Values.

PART 2 – PRODUCTS – Not Used

PART 3 – EXECUTION – Not used

End Of Section

Part 1 General

1.1 DEFINITIONS

- .1 Activity: elements of Work performed during the course of Project. Activity has expected duration, and expected cost and expected resource requirements. Activities can be subdivided into tasks.
- .2 Bar Chart (GANTT Chart): graphic display of schedule-related information. In typical bar chart, activities or other Project elements are listed down left side of chart, dates are shown across top, and activity durations are shown as date-placed horizontal bars. Generally Bar Chart should be derived from commercially available computerized project management system.
- .3 Baseline: original approved plan (for project, work package, or activity), plus or minus approved scope changes.
- .4 Construction Work Week: Monday to Friday, inclusive, will provide five day work week and define schedule calendar working days as part of Bar (GANTT) Chart submission.
- .5 Duration: number of work periods (not including holidays or other nonworking periods) required to complete activity or other project element. Usually expressed as workdays or workweeks.
- .6 Master Plan: summary-level schedule that identifies major activities and key milestones.
- .7 Milestone: significant event in project, usually completion of major deliverable.
- .8 Project Schedule: planned dates for performing activities and the planned dates for meeting milestones. Dynamic, detailed record of tasks or activities that must be accomplished to satisfy Project objectives. Monitoring and control process involves using Project Schedule in executing and controlling activities and is used as basis for decision making throughout project life cycle.

1.2 REQUIREMENTS

- .1 Ensure Master Plan and Detail Schedules are practical and remain within specified Contract duration.
- .2 Plan to complete Work in accordance with prescribed milestones and time frame.
- .3 Limit activity durations to maximum of approximately 10 working days, to allow for progress reporting.
- .4 Ensure that it is understood that Award of Contract or time of beginning, rate of progress, and Substantial Performance as defined times of completion are of essence of this contract.

1.3 ACTION AND INFORMATION SUBMITTALS

- .1 Provide submittals in accordance with Section 01 33 00 - Submittal Procedures.
- .2 Submit Project Schedule to Consultant within 5 working days of receipt of acceptance of award of Contract.

1.4 PROJECT MILESTONES

- .1 Provide Project milestones from interim targets for Project Schedule. Include the following Milestones:
 - .1 Construction Start: June 28, 2019
 - .2 Substantial Performance: August 23, 2019

1.5 PROJECT SCHEDULE

- .1 Develop detail Project Schedule
- .2 Ensure detail Project Schedule includes a minimum milestone and activity types as follows:
 - .1 Award
 - .2 Shop Drawing Submission, Samples
 - .3 Permits
 - .4 Mobilizations
 - .5 Demolition
 - .6 New Asphalt
 - .7 Close-out Documentation Submission
 - .8 Substantial Performance

1.6 PROJECT SCHEDULE REPORTING

- .1 Update Project Schedule on bi-weekly basis reflecting activity changes and completions, as well as activities in progress.
- .2 Discuss Project Schedule at regular site meetings, identifying activities that are behind schedule and provide measures to regain slippage. Activities considered behind schedule are those with projected start or completion dates later than current approved dates shown on baseline schedule
- .3 Weather related delays with their remedial measures will be discussed and negotiated.

PART 2 – PRODUCTS – Not Used

PART 3 – EXECUTION – Not used

End Of Section

Part 1 General

1.1 ADMINISTRATIVE

- .1 Submit to Consultant submittals listed for review. Submit promptly and in orderly sequence to not cause delay in Work. Failure to submit in ample time is not considered sufficient reason for extension of Contract Time and no claim for extension by reason of such default will be allowed.
- .2 Do not proceed with Work affected by submittal until review is complete.
- .3 Present shop drawings, product data, samples and mock-ups in Imperial units.
- .4 Review submittals prior to submission to Consultant. This review represents that necessary requirements have been determined and verified, or will be, and that each submittal has been checked and co-ordinated with requirements of Work and Contract Documents. Submittals not stamped, signed, dated and identified as to specific project will be returned without being examined and considered rejected.
- .5 Notify Consultant, in writing at time of submission, identifying deviations from requirements of Contract Documents stating reasons for deviations.
- .6 Verify field measurements and affected adjacent Work are co-ordinated.
- .7 Contractor's responsibility for errors and omissions in submission is not relieved by Consultant's review of submittals.
- .8 Contractor's responsibility for deviations in submission from requirements of Contract Documents is not relieved by Consultant review.
- .9 Keep one reviewed copy of each submission on site.

1.2 SHOP DRAWINGS AND PRODUCT DATA

- .1 The term "shop drawings" means drawings, diagrams, illustrations, schedules, performance charts, brochures and other data which are to be provided by Contractor to illustrate details of a portion of Work.
- .2 Submit drawings stamped and signed by professional engineer registered or licensed in Province of Ontario Canada.
- .3 Indicate materials, methods of construction and attachment or anchorage, erection diagrams, connections, explanatory notes and other information necessary for completion of Work. Where articles or equipment attach or connect to other articles or equipment, indicate that such items have been co-ordinated, regardless of Section under which adjacent items will be supplied and installed. Indicate cross references to design drawings and specifications.
- .4 Allow 7 days for Consultant's review of each submission.
- .5 Adjustments made on shop drawings by Consultant are not intended to change Contract Price. If adjustments affect value of Work, state such in writing to Consultant prior to proceeding with Work.
- .6 Make changes in shop drawings as Consultant may require, consistent with Contract Documents. When resubmitting, notify Consultant in writing of revisions other than those requested.
- .7 Accompany submissions with transmittal letter, containing:
 - .1 Date.
 - .2 Project title and number.
 - .3 Contractor's name and address.
 - .4 Identification and quantity of each shop drawing, product data and sample.
 - .5 Other pertinent data.

- .8 Submissions include:
 - .1 Date and revision dates.
 - .2 Project title and number.
 - .3 Name and address of:
 - .1 Subcontractor.
 - .2 Supplier.
 - .3 Manufacturer.
 - .4 Contractor's stamp, signed by Contractor's authorized representative certifying approval of submissions, verification of field measurements and compliance with Contract Documents.
 - .5 Details of appropriate portions of Work as applicable:
 - .1 Fabrication.
 - .2 Layout, showing dimensions, including identified field dimensions, and clearances.
 - .3 Setting or erection details.
 - .4 Capacities.
 - .5 Performance characteristics.
 - .6 Standards.
 - .7 Operating weight.
 - .8 Wiring diagrams.
 - .9 Single line and schematic diagrams.
 - .10 Relationship to adjacent work.
- .9 After Consultant's review, distribute copies.
- .10 Submit 6 prints or 1 electronic copy of shop drawings for each requirement requested in specification Sections and as Consultant may reasonably request.
- .11 Submit 6 prints or 1 electronic copies of product data sheets or brochures for requirements requested in specification Sections and as requested by Consultant where shop drawings will not be prepared due to standardized manufacture of product.
- .12 Submit 6 copies or 1 electronic copy of test reports for requirements requested in specification Sections and as requested by Consultant.
 - .1 Report signed by authorized official of testing laboratory that material, product or system identical to material, product or system to be provided has been tested in accord with specified requirements.
 - .2 Testing must have been within 3 years of date of contract award for project.
- .13 Submit 6 copies or 1 electronic copy of certificates for requirements requested in specification Sections and as requested by Consultant.
 - .1 Statements printed on manufacturer's letterhead and signed by responsible officials of manufacturer of product, system or material attesting that product, system or material meets specification requirements.
 - .2 Certificates must be dated after award of project contract complete with project name.
- .14 Submit 6 copies or 1 electronic copy of manufacturer's instructions for requirements requested in specification Sections and as requested by Consultant.
 - .1 Pre-printed material describing installation of product, system or material, including special notices and Material Safety Data Sheets concerning impedances, hazards and safety precautions.
- .15 Submit 6 copies or 1 electronic copy of Manufacturer's Field Reports for requirements requested in specification Sections and as requested by Consultant.
- .16 Documentation of the testing and verification actions taken by manufacturer's representative to confirm compliance with manufacturer's standards or instructions.
- .17 Submit 1 Hard copy and 1 digital copy (PDF Format) of Operation and Maintenance Data for requirements requested in specification Sections and as requested by Consultant.
- .18 Delete information not applicable to project.
- .19 Supplement standard information to provide details applicable to project.

- .20 If upon review by Consultant, no errors or omissions are discovered or if only minor corrections are made, copies will be returned and fabrication and installation of Work may proceed. If shop drawings are rejected, noted copy will be returned and resubmission of corrected shop drawings, through same procedure indicated above, must be performed before fabrication and installation of Work may proceed.

1.3 SAMPLES

- .1 Submit for review samples in duplicate as requested in respective specification Sections. Label samples with origin and intended use.
- .2 Deliver samples prepaid to Consultant's business address.
- .3 Notify Consultant in writing, at time of submission of deviations in samples from requirements of Contract Documents.
- .4 Where colour, pattern or texture is criterion, submit full range of samples.
- .5 Make changes in samples which Consultant may require, consistent with Contract Documents.
- .6 Reviewed and accepted samples will become standard of workmanship and material against which installed Work will be verified.

PART 2 – PRODUCTS – Not Used

PART 3 – EXECUTION – Not used

End Of Section

Part 1

General

1.1 SECTION INCLUDES

- .1 Health and safety considerations required to ensure that the Contractor shows due diligence towards health and safety on construction sites.

1.2 REFERENCES

- .1 Canada Labour Code, Part 2, Canada Occupational Safety and Health Regulations
- .2 Health Canada/Workplace Hazardous Materials Information System (WHMIS)
 - .1 Material Safety Data Sheets (MSDS).
 - .2 Occupational Health and Safety Act, S.N.S. 1996.
- .3 Province of Ontario
 - .1 Occupational Health and Safety Act, R.S.O. 1990 Updated 2005.

1.3 HEALTH & SAFETY

- .1 The Owner is firmly committed to Corporate Health & Safety.
- .2 The Contractor shall have Corporate Health and Safety Policies and Procedures as required in the Occupational Health and Safety Act and Regulations for Construction Projects, R.S.O. 1980.
- .3 To provide a safe and healthy work environment the Contractor warrants and confirms:
 - .1 that it has a written Health and Safety policy in place in accordance with the Occupational Health and Safety Act, R.S.O. 1990;
 - .2 that the appropriate instruction and training has been provided to the employees in accordance with the Occupational Health and Safety Act, R.S.O. 1990 and
 - .3 that the works shall be undertaken in strict accordance with all applicable provisions of the Occupational Health and Safety Act.
Note: In cases of discrepancy in document content, the Policy or Procedure providing the highest level of Health and Safety shall govern.
 - .4 The Bidder's documentation and commitment to Health & Safety will be a requirement of this contract.
- .4 Submit copies of incident and accident reports.

1.4 FILING OF NOTICE

- .1 File Notice of Project with Ontario Ministry of Labour prior to beginning of Work.

1.5 REGULATORY REQUIREMENTS

- .1 Do Work in accordance with Section 01 41 00 - Regulatory Requirements.

1.6 RESPONSIBILITY

- .1 Be responsible for health and safety of persons on site, safety of property on site and for protection of persons adjacent to site and environment to extent that they may be affected by conduct of Work.
- .2 Comply with and enforce compliance by employees with safety requirements of Contract Documents, applicable federal, provincial, territorial and local statutes, regulations, and ordinances.

1.7 COMPLIANCE REQUIREMENTS

- .1 Comply with Ontario Health and Safety Act, R.S.O.
- .2 Comply with Canada Labour Code, Canada Occupational Safety and Health Regulations.

1.8 UNFORSEEN HAZARDS

- .1 When unforeseen or peculiar safety-related factor, hazard, or condition occur during performance of Work, follow procedures in place for Employee's Right to Refuse Work in accordance with Acts and Regulations of Province of Ontario having jurisdiction and advise Consultant verbally and in writing.

1.9 POSTING OF DOCUMENTS

- .1 Ensure applicable items, articles, notices and orders are posted in conspicuous location on site in accordance with Acts and Regulations of Province of Ontario having jurisdiction.

1.10 CORRECTION OF NON-COMPLIANCE

- .1 Immediately address health and safety non-compliance issues identified by authority having jurisdiction or by Consultant.

.2

1.11 BLASTING

- .1 Blasting or other use of explosives is not permitted.

1.12 POWDER ACTUATED DEVICES

- .1 Powder actuated devices are not permitted.

1.13 WORK STOPPAGE

- .1 Give precedence to safety and health of public and site personnel and protection of environment over cost and schedule considerations for Work.

PART 2 – PRODUCTS – Not Used

PART 3 – EXECUTION – Not used

End Of Section

Part 1 General

1.1 FIRES

- .1 Fires and burning of rubbish on site not permitted.

1.2 DRAINAGE

- .1 Provide temporary drainage and pumping required to keep excavations and site free from water.
- .2 Ensure pumped water into waterways, sewer or drainage systems is free of suspended materials.
- .3 Control disposal or runoff of water containing suspended materials or other harmful substances in accordance with local authority requirements.

1.3 SITE CLEARING AND PLANT PROTECTION

- .1 Protect trees and plants on site and adjacent properties as indicated.
- .2 Protect roots of designated trees to dripline during excavation and site grading to prevent disturbance or damage.
- .3 Avoid unnecessary traffic, dumping and storage of materials over root zones.

1.4 POLLUTION CONTROL

- .1 Maintain temporary erosion and pollution control features installed under this Contract.
- .2 Control emissions from equipment and plant in accordance with local authorities' emission requirements.
- .3 Cover or wet down dry materials and rubbish to prevent blowing dust and debris. Provide dust control for temporary roads.

1.5 NOTIFICATION

- .1 Consultant will notify Contractor in writing of observed noncompliance with Federal, Provincial or Municipal environmental laws or regulations, permits, and other elements of Contractor's Environmental Protection plan.
- .2 Contractor: after receipt of such notice, inform Consultant of proposed corrective action and take such action for approval by Consultant.
 - .1 Take action only after receipt of written approval by Consultant.
- .3 Consultant will issue stop order of work until satisfactory corrective action has been taken.
- .4 No time extensions granted or equitable adjustments allowed to Contractor for such suspensions.

Part 2 Products - Not Used

Part 3 Execution

3.1 CLEANING

- .1 Ensure public waterways, storm and sanitary sewers remain free of waste and volatile materials disposal.
- .2 Progress Cleaning: clean in accordance with Section 01 74 11 - Cleaning.
 - .1 Leave Work area clean at end of each day.
- .3 Final Cleaning: upon completion remove surplus materials, rubbish, tools and equipment in accordance with Section 01 74 11 - Cleaning.
- .4 Waste Management: separate waste materials for reuse or recycling.
 - .1 Remove recycling containers and bins from site and dispose of materials at appropriate facility

End Of Section

Part 1 General

1.1 REFERENCES AND CODES

- .1 Perform Work in accordance with the Ontario Building Code (OBC) including amendments up to tender closing date and other codes of provincial or local application provided that in case of conflict or discrepancy, more stringent requirements apply.
- .2 Meet or exceed requirements of:
 - .1 Contract documents.
 - .2 Specified standards, codes and referenced documents.

1.2 HAZARDOUS MATERIAL DISCOVERY

- .1 Asbestos: demolition of spray or trowel-applied asbestos is hazardous to health. Stop work immediately when material resembling spray or trowel-applied asbestos is encountered during demolition work. Notify Consultant.
- .2 Mould: stop work immediately when material resembling mould is encountered during demolition work. Notify Consultant.

PART 2 – PRODUCTS – Not Used

PART 3 – EXECUTION – Not used

End Of Section

Part 1 General

1.1 INSPECTION

- .1 Allow Owner and Consultant access to Work.
- .2 If Contractor covers or permits to be covered Work that has been designated for special tests, inspections or approvals before such is made, uncover such Work, have inspections or tests satisfactorily completed and make good such Work.
- .3 Give timely notice requesting inspection if Work is designated for special tests, inspections or approvals by consultants or law of Place of Work.
- .4 Consultant will order part of Work to be examined if Work is suspected to be not in accordance with Contract Documents. If, upon examination such work is found not in accordance with Contract Documents, correct such Work and pay cost of examination and correction. If such Work is found in accordance with Contract Documents, Owner shall pay cost of examination and replacement.

1.2 REJECTED WORK

- .1 Remove defective Work, whether result of poor workmanship, use of defective products or damage and whether incorporated in Work or not, which has been rejected by Consultant as failing to conform to Contract Documents. Replace or re-execute in accordance with Contract Documents.
- .2 If in opinion of Consultant it is not expedient to correct defective Work or Work not performed in accordance with Contract Documents, Owner will deduct from Contract Price difference in value between Work performed and that called for by Contract Documents, amount of which will be determined by Consultant.

1.3 TESTING & REPORTS

- .1 Submit electronic copies of inspection and testing reports to Consultant.
- .2 Furnish test results and mix designs as requested.

1.4 MOCK-UPS

- .1 Prepare mock-ups for Work specifically requested in specifications. Include for Work of Sections required to provide mock-ups.
- .2 Prepare mock-ups for Consultants review with reasonable promptness and in orderly sequence, to not cause delays in Work.
- .3 Failure to prepare mock-ups in ample time is not considered sufficient reason for extension of Contract time and no claim for extension by reason of such default will be considered.
- .4 Mock-ups may remain as part of the work.

PART 2 – PRODUCTS – Not Used

PART 3 – EXECUTION – Not used

End Of Section

Part 1

General

1.1 INSTALLATION AND REMOVAL

- .1 Provide temporary utilities controls in order to execute work expeditiously.
- .2 Remove from site all such work after use.

1.2 DEWATERING

- .1 Provide temporary drainage and pumping facilities to keep excavations and site free from standing water.

1.3 WATER SUPPLY

- .1 Arrange, provide and pay for continuous supply of potable water for construction use.

1.4 TEMPORARY HEATING AND VENTILATION

- .1 Provide temporary heat required during construction period, including attendance, maintenance and fuel.
- .2 Construction heaters used inside building must be vented to the outside of be non-flameless type. Solid fuel salamanders are not permitted.
- .3 Provide temporary heat and ventilation in enclosed areas as required to:
 - .1 Facilitate progress of work.
 - .2 protect Work and products against dampness and cold.
 - .3 Prevent moisture condensation on surfaces.
 - .4 Provide ambient temperatures and humidity levels for storage, installation and curing of materials.
 - .5 Provide adequate ventilation to meet health and safety regulations for safe working environment.
- .4 Ventilating:
 - .1 Dispose of exhaust materials in manner that will not result in harmful exposure to persons.
 - .2 Ventilate storage spaces containing hazardous or volatile materials.
 - .3 Ventilate temporary sanitary facilities.
 - .4 Continue operation of ventilation and exhaust system for time after cessation of work process to assure removal of harmful contaminants.
- .5 Permanent heating system of building is not to be used when available.
- .6 Maintain strict supervision of operations of temporary heating and ventilation equipment to:
 - .1 Conform with applicable codes and standards.
 - .2 Enforce safe practices.
 - .3 Prevent abuse of services.
 - .4 Prevent damage to finishes.
 - .5 Vent direct-fired combustion units to outside.
- .7 Be responsible for damage to Work due to failure in providing adequate heat and protection during construction.

1.5 TEMPORARY POWER AND LIGHT

- .1 Arrange, provide and pay for temporary power during construction for operating of power tools, to a maximum supply of 230 volts 30 amps.
- .2 Arrange for connection with appropriate utility company. Pay costs for installation, maintenance and removal.
- .3 Provide and maintain temporary lighting throughout project. Ensure level of illumination on all floors and stairs is sufficient for work commencing.

1.6 TEMPORARY COMMUNICATION FACILITIES

- .1 Provide and pay for telephone, data and all necessary communication devices for own use.

1.7 FIRE PROTECTION

- .1 Burning rubbish and construction waste materials is not permitted on site.

PART 2 – PRODUCTS – Not Used

PART 3 – EXECUTION – Not used

End Of Section

Part 1 General

1.1 REFERENCES

- .1 Canadian Standards Association (CSA International)
 - .1 CAN/CSA-S269.2-M1987(R2003), Access Scaffolding for Construction Purposes.
 - .2 CAN/CSA-Z321-96(R2006), Signs and Symbols for the Occupational Environment.

1.2 INSTALLATION AND REMOVAL

- .1 Provide construction facilities in order to execute work expeditiously.
- .2 Remove from site all such work after use.

1.3 SCAFFOLDING

- .1 Scaffolding in accordance with CAN/CSA-S269.2.
- .2 Provide and maintain scaffolding, ramps, ladders, swing staging, platforms.

1.4 SITE STORAGE/LOADING

- .1 Confine work and operations of employees by Contract Documents. Do not unreasonably encumber premises with products.
- .2 Do not load or permit to load any part of Work with weight or force that will endanger Work.

1.5 CONSTRUCTION PARKING

- .1 Parking will be permitted on site in designated areas only.
- .2 Provide and maintain adequate access to project site.

1.6 EQUIPMENT, TOOL AND MATERIALS STORAGE

- .1 Provide and maintain, in clean and orderly condition, lockable weatherproof sheds for storage of tools, equipment and materials.
- .2 Locate materials not required to be stored in weatherproof sheds on site in manner to cause least interference with work activities.

1.7 SANITARY FACILITIES

- .1 Provide sanitary facilities for work force in accordance with governing regulations and ordinances.
- .2 Post notices and take precautions as required by local health authorities. Keep area and premises in sanitary condition.

1.8 CLEAN-UP

- .1 Remove construction debris, waste materials, packaging material from work site daily.
- .2 Clean dirt or mud tracked onto paved or surfaced roadways.

PART 2 – PRODUCTS – Not Used

PART 3 – EXECUTION – Not used

End Of Section

- Part 1**
- 1.1** **General**
INSTALLATION AND REMOVAL
- .1 Provide temporary controls in order to execute Work expeditiously.
 - .2 Remove from site all such work after use.
- 1.2** **SITE FENCING | PROTECTION**
- .1 Erect temporary site enclosure using new 6'-0" (1.8 m) high portable construction fence. Provide minimum one lockable truck gate. Maintain fence in good repair.
 - .2 Provide barriers around trees and plants designated to remain. Protect from damage by equipment and construction procedures.
- 1.3** **GUARD RAILS AND BARRICADES**
- .1 Provide secure, rigid guard rails and barricades around deep excavations, open shafts, open stair wells, open edges of floors and roofs.
 - .2 Provide as required by governing authorities.
- 1.4** **ACCESS TO SITE**
- .1 Provide and maintain access roads and sidewalk crossings, as may be required for access to Work.
- 1.5** **FIRE ROUTES**
- .1 Maintain access to property including overhead clearances for use by emergency response vehicles.
- 1.6** **PROTECTION FOR OFF-SITE AND PUBLIC PROPERTY**
- .1 Protect surrounding private and public property from damage during performance of Work.
 - .2 Be responsible for damage incurred.
 - .3 **DO NOT** park or drive on the church parking lot adjacent to the school yard.
- 1.7** **PROTECTION OF BUILDING FINISHES**
- .1 Provide protection for finished areas of building and equipment during performance of Work.
 - .2 Provide necessary screens, covers, and hoardings.
 - .3 Be responsible for damage incurred due to lack of or improper protection.

PART 2 – PRODUCTS – Not Used

PART 3 – EXECUTION – Not used

End Of Section

Part 1 General

1.1 REFERENCES

- .1 Within text of each specifications section, reference may be made to reference standards.
- .2 Conform to these reference standards, in whole or in part as specifically requested in specifications.
- .3 If there is question as to whether products or systems are in conformance with applicable standards, Consultant reserves right to have such products or systems tested to prove or disprove conformance.
- .4 Cost for such testing will be borne by Owner in event of conformance with Contract Documents or by Contractor in event of non-conformance.

1.2 QUALITY

- .1 Products, materials, equipment and articles incorporated in Work shall be new, not damaged or defective, and of best quality for purpose intended. If requested, furnish evidence as to type, source and quality of products provided.
- .2 Procurement policy is to acquire, in cost effective manner, items containing highest percentage of recycled and recovered materials practicable consistent with maintaining satisfactory levels of competition. Make reasonable efforts to use recycled and recovered materials and in otherwise utilizing recycled and recovered materials in execution of work.
- .3 Defective products, whenever identified prior to completion of Work, will be rejected, regardless of previous inspections. Inspection does not relieve responsibility, but is precaution against oversight or error. Remove and replace defective products at own expense and be responsible for delays and expenses caused by rejection.
- .4 Should disputes arise as to quality or fitness of products, decision rests strictly with Consultant based upon requirements of Contract Documents.
- .5 Unless otherwise indicated in specifications, maintain uniformity of manufacture for any particular or like item throughout building.
- .6 Permanent labels, trademarks and nameplates on products are not acceptable in prominent locations, except where required for operating instructions, or when located in mechanical or electrical rooms.

1.3 AVAILABILITY

- .1 Immediately upon signing Contract, review product delivery requirements and anticipate foreseeable supply delays for items. If delays in supply of products are foreseeable, notify Consultant of such, in order that substitutions or other remedial action may be authorized in ample time to prevent delay in performance of Work.
- .2 In event of failure to notify Consultant at commencement of Work and should it subsequently appear that Work may be delayed for such reason, Consultant reserves right to substitute more readily available products of similar character, at no increase in Contract Price or Contract Time.

1.4 STORAGE, HANDLING AND PROTECTION

- .1 Handle and store products in manner to prevent damage, adulteration, deterioration and soiling and in accordance with manufacturer's instructions when applicable.
- .2 Store packaged or bundled products in original and undamaged condition with manufacturer's seal and labels intact. Do not remove from packaging or bundling until required in Work.
- .3 Store products subject to damage from weather in weatherproof enclosures.
- .4 Store and mix paints in heated and ventilated room. Remove oily rags and other combustible debris from site daily. Take every precaution necessary to prevent spontaneous combustion.

- .5 Remove and replace damaged products at own expense and to satisfaction of Consultant.
 - .6 Touch-up damaged factory finished surfaces to Consultant's satisfaction. Use touch-up materials to match original. Do not paint over name plates.
- 1.5 TRANSPORTATION**
- .1 Pay costs of transportation of products required in performance of Work.
- 1.6 MANUFACTURER'S INSTRUCTIONS**
- .1 Unless otherwise indicated in specifications, install or erect products in accordance with manufacturer's instructions. Do not rely on labels or enclosures provided with products. Obtain written instructions directly from manufacturers.
 - .2 Notify Consultant in writing, of conflicts between specifications and manufacturer's instructions, so that Consultant will establish course of action.
 - .3 Improper installation or erection of products, due to failure in complying with these requirements, authorizes Consultant to require removal and re-installation at no increase in Contract Price or Contract Time.
- 1.7 QUALITY OF WORK**
- .1 Ensure Quality of Work is of highest standard, executed by workers experienced and skilled in respective duties for which they are employed. Immediately notify Consultant if required Work is such as to make it impractical to produce required results.
 - .2 Do not employ anyone unskilled in their required duties. Consultant reserves right to require dismissal from site, workers deemed incompetent or careless.
 - .3 Decisions as to standard or fitness of Quality of Work in cases of dispute rest solely with Consultant, whose decision is final.
- 1.8 CO-ORDINATION**
- .1 Ensure co-operation of workers in laying out Work. Maintain efficient and continuous supervision.
 - .2 Be responsible for coordination and placement of openings, sleeves and accessories.
- 1.9 CONCEALMENT**
- .1 In finished areas conceal pipes, ducts and wiring in floors, walls and ceilings, except where indicated otherwise.
 - .2 Before installation inform Consultant if there is interference. Install as directed by Consultant.
- 1.10 REMEDIAL WORK**
- .1 Perform remedial work required to repair or replace parts or portions of Work identified as defective or unacceptable. Co-ordinate adjacent affected Work as required.
 - .2 Perform remedial work by specialists familiar with materials affected. Perform in a manner to neither damage nor put at risk any portion of Work.
- 1.11 LOCATION OF FIXTURES**
- .1 Consider location of fixtures, outlets, and mechanical and electrical items indicated as approximate.
 - .2 Inform Consultant of conflicting installation. Install as directed.
- 1.12 FASTENINGS**
- .1 Provide metal fastenings and accessories in same texture, colour and finish as adjacent materials, unless indicated otherwise.
 - .2 Prevent electrolytic action between dissimilar metals and materials.

- .3 Use non-corrosive hot dip galvanized steel fasteners and anchors for securing exterior work, unless stainless steel or other material is specifically requested in affected specification Section.
- .4 Space anchors within individual load limit or shear capacity and ensure they provide positive permanent anchorage. Wood, or any other organic material plugs are not acceptable.
- .5 Keep exposed fastenings to a minimum, space evenly and install neatly.
- .6 Fastenings which cause spalling or cracking of material to which anchorage is made are not acceptable.

1.13 FASTENINGS - EQUIPMENT

- .1 Use fastenings of standard commercial sizes and patterns with material and finish suitable for service.
- .2 Use heavy hexagon heads, semi-finished unless otherwise specified. Use No. 304 stainless steel for exterior areas.
- .3 Bolts may not project more than one diameter beyond nuts.
- .4 Use plain type washers on equipment, sheet metal and soft gasket lock type washers where vibrations occur. Use resilient washers with stainless steel.

1.14 PROTECTION OF WORK IN PROGRESS

- .1 Prevent overloading of parts of building. Do not cut, drill or sleeve load bearing structural member, unless specifically indicated without written approval of Consultant.

1.15 EXISTING UTILITIES

- .1 When breaking into or connecting to existing services or utilities, execute Work at times directed by local governing authorities, with minimum of disturbance to Work.
- .2 Protect, relocate or maintain existing active services. When services are encountered, cap off in manner approved by authority having jurisdiction. Record location of capped service.

PART 2 – PRODUCTS – Not Used

PART 3 – EXECUTION – Not used

End Of Section

Part 1 General

1.1 SURVEY REFERENCE POINTS

- .1 Existing base horizontal and vertical control points are designated on drawings.
- .2 Locate, confirm and protect control points prior to starting site work. Preserve permanent reference points during construction.
- .3 Report to consultant when reference point is lost or destroyed, or requires relocation because of necessary changes in grades or locations.
- .4 Require surveyor to replace control points in accordance with original survey control.

1.2 SURVEY REQUIREMENTS

- .1 Establish permanent bench marks on site, referenced to established bench marks by survey control points. Record locations, with horizontal and vertical data in Project Record Documents.
- .2 Establish lines and levels, locate and lay out, by instrumentation.
- .3 Stake for grading, and fill placement.
- .4 Establish pipe invert elevations.
- .5 Stake batter boards
- .6 Establish foundations, column locations and floor elevations.
- .7 Establish lines and levels for mechanical and electrical work.

1.3 EXISTING SERVICES

- .1 Before commencing work, establish location and extent of service lines in area of Work.
- .2 Remove abandoned service lines within 6 feet of structures. Cap or otherwise seal lines at cut-off points.

1.4 LOCATION OF EQUIPMENT AND FIXTURES

- .1 Location of equipment, fixtures and outlets indicated or specified are to be considered as approximate.
- .2 Locate equipment, fixtures and distribution systems to provide minimum interference and maximum usable space and in accordance with manufacturer's recommendations for safety, access and maintenance.
- .3 Submit field drawings to indicate relative position of various services and equipment.

1.5 RECORDS

- .1 Maintain a complete, accurate log of control and survey work as it progresses.
- .2 Record locations of maintained, re-routed and abandoned service lines.

1.6 SUBSURFACE CONDITIONS

- .1 Promptly notify Consultant in writing if subsurface conditions at Place of Work differ materially from those indicated in Geotechnical Report
After prompt investigation, should Consultant determine that conditions do differ materially, instructions will be issued for changes in Work accordingly.

PART 2 – PRODUCTS – Not Used

PART 3 – EXECUTION – Not used

End of Section

Part 1 General

1.1 SUBMITTALS

- .1 Submittals: in accordance with Section 01 33 00 - Submittal Procedures.
- .2 Submit written request in advance of cutting or alteration which affects:
 - .1 Structural integrity of elements of project.
 - .2 Integrity of weather-exposed or moisture-resistant elements.
 - .3 Efficiency, maintenance, or safety of operational elements.
 - .4 Visual qualities of sight-exposed elements.
 - .5 Work of Owner or separate contractor.
- .3 Include in request:
 - .1 Identification of project.
 - .2 Location and description of affected Work.
 - .3 Statement on necessity for cutting or alteration.
 - .4 Description of proposed Work, and products to be used.
 - .5 Alternatives to cutting and patching.
 - .6 Effect on Work of Owner or separate contractor.
 - .7 Written permission of affected separate contractor.
 - .8 Date and time work will be executed.

1.2 MATERIALS

- .1 Required for original installation.
- .2 Change in Materials: Submit request for substitution in accordance with Section 01 33 00 - Submittal Procedures.

1.3 PREPARATION

- .1 Inspect existing conditions, including elements subject to damage or movement during cutting and patching.
- .2 After uncovering, inspect conditions affecting performance of Work.
- .3 Beginning of cutting or patching means acceptance of existing conditions.
- .4 Provide supports to assure structural integrity of surroundings; provide devices and methods to protect other portions of project from damage.
- .5 Provide protection from elements for areas which are to be exposed by uncovering work; maintain excavations free of water.

1.4 EXECUTION

- .1 Execute cutting, fitting, and patching to complete Work.
- .2 Fit several parts together, to integrate with other Work.
- .3 Uncover Work to install ill-timed Work.
- .4 Remove and replace defective and non-conforming Work.
- .5 Provide openings in non-structural elements of Work for penetrations of mechanical and electrical Work.
- .6 Execute Work by methods to avoid damage to other Work, and which will provide proper surfaces to receive patching and finishing.
- .7 Employ original installer to perform cutting and patching for weather-exposed and moisture-resistant elements, and sight-exposed surfaces.
- .8 Cut rigid materials using masonry saw or core drill. Pneumatic or impact tools not allowed on masonry work without prior approval.
- .9 Restore work with new products in accordance with requirements of Contract Documents.
- .10 Fit Work airtight to pipes, sleeves, ducts, conduit, and other penetrations through surfaces.
- .11 At penetration of fire rated wall, ceiling, or floor construction, completely seal voids with firestopping material, full thickness of the construction element.

- .12 Refinish surfaces to match adjacent finishes: Refinish continuous surfaces to nearest intersection. Refinish assemblies by refinishing entire unit.
- .13 Conceal pipes, ducts and wiring in floor, wall and ceiling construction of finished areas except where indicated otherwise.

PART 2 – PRODUCTS – Not Used

PART 3 – EXECUTION – Not used

End Of Section

Part 1 General

1.1 PROJECT CLEANLINESS

- .1 Maintain Work in tidy condition, free from accumulation of waste products and debris.
- .2 Remove waste materials from site at regularly scheduled times. Do not burn waste materials on site.
- .3 Clear snow and ice from access to building, remove from site.
- .4 Make arrangements with and obtain permits from authorities having jurisdiction for disposal of waste and debris.
- .5 Provide on-site containers for collection of waste materials and debris.
- .6 Provide and use marked separate bins for recycling.
- .7 Dispose of waste materials and debris off site.
- .8 Clean interior areas prior to start of finishing work, and maintain areas free of dust and other contaminants during finishing operations.
- .9 Store volatile waste in covered metal containers, and remove from premises at end of each working day.
- .10 Provide adequate ventilation during use of volatile or noxious substances. Use of building ventilation systems is not permitted for this purpose.
- .11 Use only cleaning materials recommended by manufacturer of surface to be cleaned, and as recommended by cleaning material manufacturer.
- .12 Schedule cleaning operations so that resulting dust, debris and other contaminants will not fall on wet, newly painted surfaces nor contaminate building systems.

1.2 FINAL CLEANING

- .1 Refer to CCDC 2, GC 3.14.
- .2 When Work is Substantially Performed remove surplus products, tools, construction machinery and equipment not required for performance of remaining Work.
- .3 Remove waste products and debris other than that caused by others, and leave Work clean and suitable for occupancy.
- .4 Prior to final review remove surplus products, tools, construction machinery and equipment.
- .5 Remove waste materials from site at regularly scheduled times. Do not burn waste materials on site.
- .6 Make arrangements with and obtain permits from authorities having jurisdiction for disposal of waste and debris.
- .7 Clean and polish glass, mirrors, hardware, wall tile, stainless steel, chrome, porcelain enamel, baked enamel, plastic laminate, and mechanical and electrical fixtures. Replace broken, scratched or disfigured glass.
- .8 Remove stains, spots, marks and dirt from decorative work, electrical and mechanical fixtures, furniture fitments, walls, ceilings, floors.
- .9 Clean lighting reflectors, lenses, and other lighting surfaces.
- .10 Vacuum clean and dust building interiors, behind grilles, louvres and screens.
- .11 Wax, seal, shampoo or prepare floor finishes, as recommended by manufacturer.
- .12 Inspect finishes, fitments and equipment and ensure specified workmanship and operation.
- .13 Broom clean and wash exterior walks, steps and surfaces; rake clean other surfaces of grounds.
- .14 Remove dirt and other disfiguration from exterior surfaces.
- .15 Clean and sweep roofs, gutters, areaways, and sunken wells.
- .16 Sweep and wash clean paved areas.
- .17 Clean equipment and fixtures to sanitary condition; clean or replace filters of mechanical equipment.
- .18 Clean roofs, downspouts, and drainage systems.
- .19 Remove debris and surplus materials from crawl areas and other accessible concealed spaces.

.20 Remove snow and ice from access to building.

1.3 WASTE MANAGEMENT AND DISPOSAL

.1 Separate waste materials for reuse or recycling.

PART 2 – PRODUCTS – Not Used

PART 3 – EXECUTION – Not used

End Of Section

Part 1 General

1.1 ADMINISTRATIVE PROCEDURES

- .1 Acceptance of Work Procedures:
 - .1 Contractor's Inspection: conduct inspection of Work , identify deficiencies and defects, and repair as required to conform to Contract documents.
 - .2 Notify Consultant in writing of satisfactory completion of Contractors inspection and submit verification that corrections have been made.
 - .3 Request Consultants inspections
 - .4 Consultants and Contactor to inspect Work and identify defects and deficiencies. Contractor to correct Work as directed.
- .2 Completion Tasks: submit written certificates and tasks have been preformed as follows:
 - .1 Work completed and inspected in compliance with Contract Documents.
 - .2 Defects / deficiencies have been corrected and completed
 - .3 Equipment and systems: Tested m balanced and fully operation as per Mechanical and electrical specifications.
 - .4 Operations of systems demonstrated to Owner's personnel.

1.2 CLOSEOUT PROCEDURES

- .1 The Consultant will not commence deficiency review until the General Contractor's own itemized deficiencies have been completed. The Consultant will make one inspection for deficiencies review and one final review at competition of all items. Each additional Site review will be made at a cost of \$1,200.00 per visit to be paid by the General Contractor.
- .2 Contractor to accompany Consultant on deficiency inspection.
- .3 Contractor to correct items of work listed on deficiency list in a efficient manner to allow owner areas to be turn over to Owner in a timely manner.
- .4 Notify in writing to Consultant when all corrective work is completed.

1.3 ACTION AND INFORMATIONAL SUBMITTALS

- .1 Two weeks prior to Substantial Performance of the Work, submit to the Consultant one (1) hard copy and one (1) digital copy of final operating and maintenance manuals in English, and hard copy of Record Drawings.
- .2 Provide spare parts, maintenance materials and special tools of same quality and manufacture as products provided in Work.

1.4 FORMAT

- .1 Organize data as instructional manual.
- .2 Binders: vinyl, hard covered, 3 'D' ring, loose leaf, to suit 8 ½' x 11" size paper, with spine and face pockets.
- .3 Cover: identify each binder with type or printed title 'Project Record Documents'; list title of project and identify subject matter of contents.
- .4 Arrange content by systems, under Section numbers and sequence of Table of Contents.
- .5 Provide tabbed fly leaf for each separate product and system, with typed description of product and major component parts of equipment.
- .6 Text: manufacturer's printed data, or typewritten data.
- .7 Drawings: provide with reinforced punched binder tab, bind in with text; fold larger drawings to size of text pages.

1.5 CONTENTS - PROJECT RECORD DOCUMENTS

- .1 Table of Contents for Each Volume: provide title of project;
 - .1 Date of submission; names.
 - .2 Addresses, and telephone numbers of Consultant and Contractor with name of responsible parties.

- .3 Schedule of products and systems, indexed to content of volume.
- .2 For each product or system:
 - .1 List names, addresses and telephone numbers of subcontractors and suppliers, including local source of supplies and replacement parts.
- .3 Product Data: mark each sheet to identify specific products and component parts, and data applicable to installation; delete inapplicable information.
- .4 Drawings: supplement product data to illustrate relations of component parts of equipment and systems, to show control and flow diagrams.
- .5 Typewritten Text: as required to supplement product data.
 - .1 Provide logical sequence of instructions for each procedure, incorporating manufacturer's instructions.
- .6 As Built Drawings: digital copies will be prepared by the Consultant.

1.6 AS -BUILT DOCUMENTS AND SAMPLES

- .1 Maintain, at site one record copy of:
 - .1 Contract Drawings.
 - .2 Specifications.
 - .3 Addenda.
 - .4 Change Orders and other modifications to Contract.
 - .5 Reviewed shop drawings, product data, and samples.
 - .6 Field test records.
 - .7 Inspection certificates.
 - .8 Manufacturer's certificates.
- .2 Store record documents and samples in field office apart from documents used for construction.
- .3 Maintain record documents in clean, dry and legible condition. Do not use record documents for construction purposes.
- .4 Keep record documents and samples available for inspection by Consultant.

1.7 RECORDING INFORMATION ON PROJECT RECORD DOCUMENTS

- .1 Record information on set of opaque drawings.
- .2 Use felt tip or ball point pens to record information, maintaining separate colours for each major system.
- .3 Record information concurrently with construction progress. Do not conceal Work until required information is recorded.
- .4 Contract Drawings and shop drawings: mark each item to record actual construction, including:
 - .1 Field changes of dimension and detail.
 - .2 Changes made by change orders.
 - .3 Details not on original Contract Drawings.
 - .4 References to related shop drawings and modifications.
- .5 Other Documents: maintain manufacturer's certifications, inspection certifications, field test records, required by individual specifications sections.
- .6 Provide digital photos, if requested, for site records.
- .7 Prior to Substantial Performance deliver Record Documents to Consultant for preparation of digital As Built Drawings. Consultant will transfer notations from opaque drawings to digital format.

1.8 MATERIALS AND FINISHES

- .1 Building products, applied materials, and finishes: include product data, with catalogue number, size, composition, and colour and texture designations.
- .2 Instructions for cleaning agents and methods, precautions against detrimental agents and methods, and recommended schedule for cleaning and maintenance.

- .3 Moisture-protection and weather-exposed products: include manufacturer's recommendations for cleaning agents and methods, precautions against detrimental agents and methods, and recommended schedule for cleaning and maintenance.
- .4 Additional requirements: as specified in individual specifications sections.

1.9 MAINTENANCE MATERIALS

- .1 Spare Parts, Extra Stock Materials and Special Tools:
 - .1 Provide, in quantities specified in individual specification sections.
 - .2 Provide items of same manufacture and quality as items in Work.
 - .3 Deliver to site; place and store.
 - .4 Receive and catalogue items.
 - .1 Include inventory listings in Maintenance Manual.
 - .5 Obtain receipt for delivered products and submit prior to final payment.

1.10 DELIVERY, STORAGE AND HANDLING

- .1 Store spare parts, maintenance materials, and special tools in manner to prevent damage or deterioration.
- .2 Store in original and undamaged condition with manufacturer's seal and labels intact.
- .3 Store components subject to damage from weather in weatherproof enclosures.
- .4 Store paints and freezable materials in a heated and ventilated room.

1.11 WARRANTIES AND BONDS

- .1 Assemble warranty and bond information in binder, submit upon acceptance of work and organize binder as follows:
 - .1 Separate each warranty or bond with index tab sheets keyed to Table of Contents listing.
 - .2 List subcontractor, supplier, and manufacturer, with name, address, and telephone number of responsible principal.
 - .3 Obtain warranties and bonds, executed in duplicate by subcontractors, suppliers, and manufacturers, within ten days after completion of applicable item of work.
 - .4 Verify that documents are in proper form, contain full information, and are notarized.
 - .5 Co-execute submittals when required.
 - .6 Retain warranties and bonds until time specified for submittal.
- .2 Leave date of beginning of time of warranty until Date of Substantial Performance is determined.
- .3 Respond in timely manner to oral or written notification of required construction warranty repair work.

PART 2 – PRODUCTS – Not Used

PART 3 – EXECUTION – Not used

End Of Section

Part 1 General

1.1 ADMINSTARTIVE REQUIREMENTS

- .1 Demonstrate operation and maintenance of equipment and systems to Owner's personnel one week prior to date of substantial performance.
- .2 Owner: provide list of personnel to receive instructions, and co-ordinate their attendance at agreed-upon times.
- .3 Preparation:
 - .1 Verify conditions for demonstration and instructions comply with requirements.
 - .2 Verify designated personnel are present.
 - .3 Ensure equipment has been inspected and put into operation in accordance with Mechanical and electrical Specifications
 - .4 Ensure testing, adjusting, and balancing has been performed [in accordance with Mechanical and electrical Specifications and equipment and systems are fully operational.
- .4 Demonstration and Instructions:
 - .1 Demonstrate start-up, operation, control, adjustment, trouble-shooting, servicing, and maintenance of each item of equipment.
 - .2 Instruct personnel in phases of operation and maintenance using operation and maintenance manuals as basis of instruction.
 - .3 Review contents of manual in detail to explain aspects of operation and maintenance.
 - .4 Prepare and insert additional data in operations and maintenance manuals when needed during instructions.
- .5 Time Allocated for Instructions: allow adequate time required for instruction of each item of equipment.

1.2 QUALITY CONTROL

- .1 When specified in individual Sections requiring manufacturer to provide authorized representative to demonstrate operation of equipment and systems:
 - .1 Instruct Owner's personnel of time and location.
 - .2 Provide written report that demonstration and instructions have been completed.

PART 2 – PRODUCTS – Not Used

PART 3 – EXECUTION – Not used

End of Section

Part 1 General

1.1 REFERENCES

- .1 Canadian Standards Association (CSA International)
 - .1 CSA S350-(R2003), Code of Practice for Safety in Demolition of Structures.

1.2 SITE CONDITIONS

- .1 Take precautions to protect the environment.
 - .1 Do not proceed until written instructions have been received from Consultant.
- .2 Notify Owner and Consultant in writing, minimum 6 days before disrupting building access or services.

Part 2 Products - Not Used

Part 3 Execution

3.1 EXAMINATION

- .1 Inspect site with Consultant and verify extent and location of items designated for removal, disposal, alternative disposal, recycling, salvage and items to remain.
- .2 Locate and protect utilities. Preserve active utilities traversing site in operating condition.
- .3 Notify and obtain approval of utility companies before starting demolition.
- .4 Disconnect, cap, plug or divert, as required, existing public utilities within the property where they interfere with the execution of the work, in conformity with the requirements of the authorities having jurisdiction. Mark the location of these and previously capped or plugged services on the site and indicate location (horizontal and vertical) on the record drawings. Support, shore up and maintain pipes and conduits encountered.
 - .1 Immediately notify Consultant and utility company concerned in case of damage to any utility or service, designated to remain in place.
 - .2 Immediately notify the Consultant should uncharted utility or service be encountered, and await instruction in writing regarding remedial action.

3.2 PREPARATION

- .1 Temporary Erosion and Sedimentation Control:
 - .1 Provide temporary erosion and sedimentation control measures to prevent soil erosion and discharge of soil-bearing water runoff or airborne dust to adjacent properties and walkways,
 - .2 Remove erosion and sedimentation controls and restore and stabilize areas disturbed during removal after completion of demolition work..
- .2 Protection of In-Place Conditions:
 - .1 Prevent movement, settlement, or damage to adjacent structures, utilities, and landscaping features to remain in place. Provide bracing and shoring required.
 - .2 Keep noise, dust, and inconvenience to occupants to minimum.
 - .3 Protect building systems, services and equipment.
 - .4 Provide temporary dust screens, covers, railings, supports and other protection as required.
 - .5 Do Work in accordance with Section 01 35 29 - Health and Safety Requirements.

- .3 Demolition/Removal:
 - .1 Remove items as indicated.
 - .2 Removal of Pavements, Curbs and Gutters:
 - .1 Square up adjacent surfaces to remain in place by saw cutting or other method approved by Consultant.
 - .2 Protect adjacent joints and load transfer devices.
 - .3 Protect underlying and adjacent granular materials designated to remain.

3.3

CLEANING

- .1 Progress Cleaning: clean in accordance with Section 01 74 11 - Cleaning.
 - .1 Leave Work area clean at end of each day.
- .2 Final Cleaning: upon completion remove surplus materials, rubbish, tools and equipment in accordance with Section 01 74 11 - Cleaning.
- .3 Refer to demolition drawings and specifications for items to be salvaged for reuse.
- .4 Waste Management: separate waste materials for reuse or recycling.
 - .1 Remove recycling containers and bins from site and dispose of materials at appropriate facility.

End Of Section

Part 1 General

1.1 RELATED SECTIONS

- .1 Finish Carpentry: Section 06 20 00

1.2 REFERENCES

- .1 American Society for Testing and Materials International (ASTM)
 - .1 ASTM A653/A653M-09, Standard Specification for Steel Sheet, Zinc-Coated (Galvanized) or Zinc-Iron Alloy-Coated (Galvanealloyed) by the Hot-Dip Process.
 - .2 ASTM D1761-12, Standard Test Methods for Mechanical Fasteners in Wood.
- .2 Canadian General Standards Board (CGSB)
 - .1 CAN/CGSB-71.26-M88, Adhesive for Field-Gluing Plywood to Lumber Framing for Floor Systems.
- .3 Canadian Standards Association (CSA International)
 - .1 CSA B111-1974(R2003), Wire Nails, Spikes and Staples.
 - .2 CSA O121- R2008, Douglas Fir Plywood.
 - .3 CSA O141-05(R09), Softwood Lumber.
 - .4 CSA O151-09, Canadian Softwood Plywood.
- .4 National Lumber Grades Authority (NLGA)
 - .1 Standard Grading Rules for Canadian Lumber 2014.

1.3 SUBMITTALS

- .1 Submit Submittal submissions: in accordance with Section 01 33 00 - Submittal Procedures.

1.4 QUALITY ASSURANCE

- .1 Lumber by grade stamp of an agency certified by Canadian Lumber Standards Accreditation Board.
- .2 Plywood, particleboard, OSB and wood based composite panels in accordance with CSA and ANSI standards.

1.5 DELIVERY, STORAGE, AND HANDLING

- .1 Waste Management and Disposal:
 - .1 Separate waste materials for reuse and recycling.

Part 2 Products

2.1 FRAMING AND STRUCTURAL MATERIALS

- .1 Lumber: unless specified otherwise, softwood, S4S, moisture content 19% (S-dry) or less in accordance with following standards:
 - .1 CSA O141.
 - .2 NLGA Standard Grading Rules for Canadian Lumber.
- .2 Framing and board lumber: in accordance with OBC.
- .3 Furring, blocking, nailing strips, grounds, rough bucks:
 - .1 S2S is acceptable for all.
 - .2 Board sizes: "Standard" or better grade.
 - .3 Dimension sizes: "Standard" light framing or better grade.
 - .4 Post and timbers sizes: "Standard" or better grade.

2.2 PANEL MATERIALS

- .1 Plywood, OSB and wood based composite panels: to CSA O325.
- .2 Douglas fir plywood (DFP): to CSA O121, standard construction.
- .3 Canadian softwood plywood (CSP): to CSA O151, standard construction.
- .4 Poplar plywood (PP): to CSA O153, standard construction.
- .5 Gypsum sheathing: to ASTM C1396/C1396M, regular and Type X. Acceptable product: Georgia Pacific Dens Glass Sheathing and Dens Glass Sheathing Type X or approved alternate.

2.3 ACCESSORIES

- .1 Air seal (gaskets): closed cell polyurethane or polyethylene.
- .2 Sealants: in accordance with Section 07 92 00 - Joint Sealants.
- .3 General purpose adhesive: to CSA O112.9.
- .4 Nails, spikes and staples: to CSA B111.
- .5 Bolts: ½" (12.5 mm) diameter unless indicated otherwise, complete with nuts and washers.
- .6 Proprietary fasteners: toggle bolts, expansion shields and lag bolts, screws and lead or inorganic fibre plugs, recommended for purpose by manufacturer.
- .7 Fastener Finishes:
 - .1 Galvanizing: to ASTM A123/A123M. Use galvanized fasteners for exterior work, interior highly humid areas, pressure-preservative treated lumber.

2.4 FASTENER FINISHES

- .1 Galvanizing: to CAN/CSA-G164, use galvanized fasteners for exterior work.

Part 3 Execution

3.1 PREPARATION

- .1 Treat surfaces of material with wood preservative, before installation.
- .2 Apply preservative by dipping, or by brush to completely saturate and maintain wet film on surface for minimum 3 minute soak on lumber and one minute soak on plywood.
- .3 Re-treat surfaces exposed by cutting, trimming or boring with liberal brush application of preservative before installation.
- .4 Treat material as indicated and as follows:
 - .1 Wood cants, fascia backing, curbs, nailers, sleepers on roof deck.
 - .2 Wood furring for applied items on outside surface of exterior masonry and concrete walls.
 - .3 Wood sleepers supporting wood subflooring over concrete slabs in contact with ground or fill.

3.2 INSTALLATION

- .1 Comply with requirements of OBC 2012 Part 9 supplemented by following:
- .2 Install members true to line, levels and elevations, square and plumb.
- .3 Construct continuous members from pieces of longest practical length.
- .4 Install spanning members with "crown-edge" up.
- .5 Select exposed framing for appearance. Install lumber and panel materials so that grade-marks and other defacing marks are concealed or are removed by sanding where materials are left exposed.
- .6 Install subflooring with panel end-joints located on solid bearing, staggered at least 32" (800 mm)
 - .1 In addition to mechanical fasteners, floor panels secure floor subflooring to floor joists using glue. Place continuous adhesive bead in accordance with manufacturer's instructions, single-bead on each joist and double-bead on joists where panel ends butt.

- .7 Install Exterior Gypsum Board wall sheathing in accordance with manufacturer's printed instructions.
- .8 Install plywood roof sheathing in accordance with requirements of OBC.
- .9 Install furring and blocking as required to space-out and support casework, cabinets, wall and ceiling finishes, facings, parapets, fascia, soffit, electrical equipment backboards and other work as required.
- .10 Install furring to support siding applied vertically [where there is no blocking and] where sheathing is not suitable for direct nailing.
- .11 Install rough bucks, nailers and linings to rough openings as required to provide backing for frames and other work.
- .12 Install wood fascia backing, nailers, curbs and other wood supports as required and secure using galvanized fasteners.
- .13 Install wood cants and parapets, fascia backing, nailers, curbs and other wood supports as required and secure using galvanized fasteners.
- .14 Install sleepers as indicated.
- .15 Use dust collectors and high quality respirator masks when cutting or sanding wood panels.
- .16 Frame, anchor, fasten, tie and brace members to provide necessary strength and rigidity.
- .17 Countersink bolts where necessary to provide clearance for other work.

3.3 ERECTION

- .1 Frame, anchor, fasten, tie and brace members to provide necessary strength and rigidity.
- .2 Countersink bolts where necessary to provide clearance for other work.
- .3 Use nailing disks for soft sheathing as recommended by sheathing manufacturer.

3.4 SCHEDULE

- .1 Exterior wall sheathing:
 - .1 Gypsum sheathing, square panel edge, thickness as indicated, regular and Type X.
- .2 Electrical equipment mounting boards:
 - .1 Plywood, DFP or CSP G1S, square edge ¾" (19 mm) thick.

3.5 CLEANING

- .1 Progress Cleaning: clean in accordance with Section 01 74 11 - Cleaning.
 - .1 Leave Work area clean at end of each day.
- .2 Final Cleaning: upon completion remove surplus materials, rubbish, tools and equipment in accordance with Section 01 74 11 - Cleaning.
- .3 Waste Management: separate waste materials for reuse or recycling.
 - .1 Remove recycling containers and bins from site and dispose of materials at appropriate facility.

3.6 PROTECTION

- .1 Protect installed products and components from damage during construction.
- .2 Repair damage to adjacent material caused by rough carpentry installation.

End Of Section

Part 1 General

1.1 RELATED REQUIREMENTS

- .1 Rough Carpentry: Section 06 10 00
- .2 Door Hardware: Section 08 71 00

1.2 REFERENCES

- .1 American National Standards Institute (ANSI)
 - .1 ANSI/HPVA HP-1-2004, American National Standard for Hardwood and Decorative Plywood.
- .2 Architectural Woodwork Manufacturers Association of Canada (AWMAC) and Architectural Woodwork Institute (AWI)
 - .1 Architectural Woodwork Quality Standards, 1st edition, 2009.
- .3 CSA International
 - .1 CSA B111-1974(R2003), Wire Nails, Spikes and Staples.
 - .2 CSA O121- R2008, Douglas Fir Plywood.
 - .3 CSA O141-05(R09), Softwood Lumber.
 - .4 CSA O151-09, Canadian Softwood Plywood.
- .4 National Lumber Grades Authority (NLGA)
 - .1 NLGA Standard Grading Rules for Canadian Lumber 2014.

1.3 ACTION AND INFORMATIONAL SUBMITTALS

- .1 Submit in accordance with Section 01 33 00 - Submittal Procedures.
- .2 Shop Drawings:
 - .1 Submit drawings indicating details of construction, profiles, jointing, fastening and other related details.
 - .2 Indicate materials, thicknesses, finishes and hardware.

1.4 QUALITY ASSURANCE

- .1 Lumber by grade stamp of agency certified by Canadian Lumber Standards Accreditation Board (CLSAB).
- .2 Plywood, particleboard, OSB and wood based composite panels to CSA and ANSI standards.
- .3 Wood fire rated frames and panels: listed and labelled by an organization accredited by Standards Council of Canada to CAN4-S104 and CAN/ULC-S105.

1.5 DELIVERY, STORAGE AND HANDLING

- .1 Deliver, store and handle materials in accordance with Section 01 61 00 - Common Product Requirements and with manufacturer's written instructions.
- .2 Storage and Handling Requirements:
 - .1 Store materials in dry location and in accordance with manufacturer's recommendations in clean, dry, well-ventilated area.
 - .2 Store and protect wood products from nicks, scratches, and blemishes.
 - .3 Replace defective or damaged materials with new.
- .3 Packaging Waste Management: remove for reuse and recycling.

Part 2 Products

2.1 MATERIALS

- .1 Softwood lumber: S4S, moisture content 19% or less in accordance with following standards:
 - .1 CSA O141.
 - .2 NLGA Standard Grading Rules for Canadian Lumber.
 - .3 AWMAC custom grade, moisture content as specified.
 - .4 Machine stress-rated lumber is acceptable.
- .2 Hardwood lumber: moisture content 10 % or less in accordance:
 - .1 National Hardwood Lumber Association (NHLA).
 - .2 AWMAC custom grade, moisture content as specified.

2.2 ACCESSORIES

- .1 Nails and staples: to CSA B111; galvanized to CAN/CSA-G164 for exterior work, interior humid areas and for treated lumber; plain finish elsewhere.
- .2 Wood screws: plain, type and size to suit application.

Part 3 Execution

3.1 EXAMINATION

- .1 Verification of Conditions: verify conditions of substrates previously installed under other Sections or Contracts are acceptable for wood products installation in accordance with manufacturer's written instructions.
 - .1 Visually inspect substrate.
 - .2 Inform Consultant of unacceptable conditions immediately upon discovery.
 - .3 Proceed with installation only after unacceptable conditions have been remedied.

3.2 INSTALLATION

- .1 Do finish carpentry to Quality Standards of (AWMAC).
- .2 Scribe and cut as required, fit to abutting walls, and surfaces, fit properly into recesses and to accommodate piping, columns, fixtures, outlets, or other projecting, intersecting or penetrating objects.
- .3 Form joints to conceal shrinkage.

3.3 CONSTRUCTION

- .1 Fastening:
 - .1 Position items of finished carpentry work accurately, level, plumb, true and fasten or anchor securely.
 - .2 Design and select fasteners to suit size and nature of components being joined. Use proprietary devices as recommended by manufacturer.
 - .3 Set finishing nails to receive filler. Where screws are used to secure members, countersink screw in round smooth cut hole and plug with wood plug to match material being secured.
 - .4 Replace items of finish carpentry with damage to wood surfaces including hammer and other bruises.
- .2 Shelving:
 - .1 Install shelving as indicated.
- .3 Hardware:
 - .1 Install door hardware in accordance with manufacturer's instructions and templates.

3.4 CLEANING

- .1 Progress Cleaning: clean in accordance with Section 01 74 11 - Cleaning.
 - .1 Leave Work area clean at end of each day.
- .2 Final Cleaning: upon completion remove surplus materials, rubbish, tools and equipment in accordance with Section 01 74 11 - Cleaning.
- .3 Waste Management: separate waste materials for reuse and recycling.
 - .1 Remove recycling containers and bins from site and dispose of materials at appropriate facility.

3.5 PROTECTION

- .1 Protect installed products and components from damage during construction.
- .2 Repair damage to adjacent materials caused by finish carpentry installation.

End Of Section

- Part 1**
- 1.1 General**
- 1.1 RELATED REQUIREMENTS**
- .1 Section 06 10 00: Rough Carpentry
 - .2 Section 09 21 16: Gypsum Board Assemblies
- 1.2 REFERENCES**
- .1 ASTM C665-01e Specification for Mineral-Fiber Blanket Thermal Insulation for Light Frame Construction and Manufactured Housing.
 - .2 ASTM C1320-05, Standard Practice for Installation of Mineral Fiber Batt and Blanket Thermal Insulation for Light Frame Construction.
 - .2 Canadian Standards Association (CSA International)
 - .1 CSA B111-1974(R2003), Wire Nails, Spikes and Staples.
 - .3 Underwriters Laboratories of Canada (ULC)
 - .1 CAN/ULC-S702-1997, Standard for Mineral Fibre Insulation.
- 1.3 ACTION AND INFORMATIONAL SUBMITTALS**
- .1 Product Data:
 - .1 Submit manufacturer's printed product literature, specifications and data sheet in accordance with Section 01 33 00 - Submittal Procedures.
 - .2 Manufacturer's Instructions:
 - .1 Submit manufacturer's installation instructions.
- 1.4 QUALITY ASSURANCE**
- .1 Test Reports: certified test reports showing compliance with specified performance characteristics and physical properties.
 - .2 Certificates: product certificates signed by manufacturer certifying materials comply with specified performance characteristics and criteria and physical requirements.
 - .3 Health and Safety Requirements: do construction occupational health and safety in accordance with Section 01 35 29 - Health and Safety Requirements.
- 1.5 WASTE MANAGEMENT AND DISPOSAL**
- .1 Separate waste materials for reuse or recycling.
 - .2 Remove from site and dispose of packaging materials at appropriate recycling facilities.
- Part 2**
- 2.1 Products**
- 2.1 INSULATION**
- .1 Acoustical and fire batt insulation for walls and floors to CAN/ULC S702, Type 1.
 - .1 Fire performance:
 - .1 Non-combustibility: To CAN/ULC S114.
 - .2 Surface Burning Characteristics: To CAN/ULC S102.
 - .1 Flame spread: 0.
 - .2 Smoke developed: 0
 - .3 Smoulder resistance: 0.09% to CAN/ULC S129.
 - .2 Acoustical Performance:
 - .1 Airborne sound transmission loss: To ASTM E90.
 - .2 Rating sound insulation: To ASTM E413.
 - .3 Sound absorption co-efficients: To ASTM C423.
 - .3 Refer to drawings for thickness required
 - .4 Acceptable Product:
 - .1 Roxul AFB
 - .2 Owens Corning Ecotouch Quietzone
 - .3 or approved alternate

2.2 ACCESSORIES

- .1 Nails: galvanized steel, length to suit insulation plus 1" (25 mm), to CSA B111.
- .2 Staples: ½" (12 mm) minimum leg.
- .3 Tape: as recommended by manufacturer.

Part 3 Execution

3.1 MANUFACTURER'S INSTRUCTIONS

- .1 Compliance: comply with manufacturer's written data, including product technical bulletins, product catalogue installation instructions, product carton installation instructions, and data sheets.

3.2 INSULATION INSTALLATION

- .1 Install insulation to maintain continuity of thermal protection to building elements and spaces and to provide sound attenuation.
- .2 Fit insulation closely around electrical boxes, pipes, ducts, frames and other objects in or passing through insulation.
- .3 Do not compress insulation to fit into spaces.
- .4 Keep insulation minimum 3" (75 mm) from heat emitting devices such as recessed light fixtures, and minimum 2" (50 mm) from CAN/CGA-B149.1 and CAN/CGA-B149.2 Type B vents.
- .5 Do not enclose insulation until it has been inspected and approved by Consultant.

3.3 CLEANING

- .1 Upon completion of installation, remove surplus materials, rubbish, tools and equipment barriers.

End Of Section

Part 1 General

1.1 RELATED SECTIONS

- .1 Joint Sealants: Section 07 90 00
- .2 Gypsum Board Assemblies: Section 09 21 16

1.2 REFERENCES

- .1 ASTM E814, Test Method for Fire Tests of Through-Penetration Fire Stops
- .2 CAN/CGSB 19.13, Sealing Compound, One Component, Elastomeric, Chemical Curing.
- .3 CAN/ULC S102, Surface Burning Characteristics of Building Materials and Assemblies.
- .4 Can\ULC S115, Standard Method of Fire tests of Firestop Systems.
- .5 CAN/ULC S702, Thermal Insulation, Mineral Fibre for Buildings

1.3 DEFINITIONS

- .1 Fire Stop Material: device intended to close off opening or penetration during fire or materials that fill openings in wall or floor assembly where penetration is by cables, cable trays, conduits, ducts and pipes and poke-through termination devices, including electrical outlet boxes along with their means of support through wall or floor openings.
- .2 Single Component Fire Stop System: fire stop material that has Listed Systems Design and is used individually without use of high temperature insulation or other materials to create fire stop system.
- .3 Multiple Component Fire Stop System: exact group of fire stop materials that are identified within Listed Systems Design to create on site fire stop system.
- .4 Tightly Fitted; (ref: NBC Part 3.1.9.1.1 and 9.10.9.6.1): penetrating items that are cast in place in buildings of noncombustible construction or have "0" annular space in buildings of combustible construction.
 - .1 Words "tightly fitted" should ensure that integrity of fire separation is such that it prevents passage of smoke and hot gases to unexposed side of fire separation.

1.4 SUBMITTALS

- .1 Provide submittals in accordance with Section 01 33 00 - Submittal Procedures.
- .2 Product Data:
 - .1 Submit manufacturer's printed product literature, specifications and datasheet and include product characteristics, performance criteria, physical size, finish and limitations.
 - .2 Submit two (2) copies of WHMIS MSDS - Material Safety Data Sheets.
- .3 Shop Drawings:
 - .1 Submit shop drawings to show proposed material, reinforcement, anchorage, fastenings and method of installation.
 - .2 Construction details should accurately reflect actual job conditions.
- .4 Samples:
 - .1 Submit samples showing actual firestopping material and smoke seal material as requested.
- .5 Manufacturer's Instructions:
 - .1 Submit manufacturer's installation instructions and special handling criteria, installation sequence, cleaning procedures and certificates.

1.5 QUALITY ASSURANCE

- .1 Manufacturer's Qualifications: Company specializing in manufacturing products of this Section with minimum Five (5) years documented experience in quality management systems.
- .2 Installer's Qualifications: Provide work of the Section executed by competent installers experienced, trained and approved by the material or system manufacturer for the

application of materials and systems being used have a minimum of three (3) years experience.

- .3 Single Source Responsibility: Ensure primary material are obtained from 1 source by a single manufacture and secondary materials are obtained from source recommended by primary material manufacturer.

1.6 DELIVERY, STORAGE AND HANDLING

- .1 Packing, shipping, handling and unloading:
 - .1 Deliver, store and handle materials in accordance with Section 01 61 00 - Common Product Requirements
 - .2 Deliver, store and handle materials in accordance with manufacturer's written instructions.
 - .3 Deliver materials to the site in undamaged condition and in original unopened containers, marked to indicate manufacturer and ULC markings.
- .2 Storage and Protection:
 - .1 Store materials indoors and in accordance with manufacturer's recommendations in clean, dry, well-ventilated area.
 - .2 Replace defective or damaged materials with new.

1.7 PROJECT CONDITIONS

- .1 Comply with Manufacturer's recommended requirements for temperature, relative humidity and substrate conditions during application and curing of materials.

1.8 SCHEDULING

- .1 Co-ordinate installation of work of this Section with work of other trades to ensure firestopping and smoke sealing applications can be inspected prior to being covered by subsequent construction.

Part 2 Products

2.1 MATERIALS

- .1 Fire Stopping and smoke seal systems: in accordance with CAN-ULC-S115.
 - .1 Asbestos-free material and systems capable of maintaining effective barrier against flame, smoke and gases in compliance with requirements of CAN-ULC-S115 and not to exceed opening sizes for which they are intended.
 - .2 Fire Stop Rating: Equal to assembly rating material or system is located.
- .2 Service Penetrations assemblies: systems tested to CAN-ULC-S115.
- .3 Service Penetration fire stop component: certified by test laboratory to CAN-ULC-S115.
- .4 Fire-resistance rating of installed fire stopping assembly in accordance with NBC.
- .5 Fire stopping and smoke seals at openings intended for ease of re-entry such as cables: elastomeric seal.
- .6 Fire stopping and smoke seals at openings around penetrations for pipes, ductwork and other mechanical items requiring sound and vibration control: elastomeric seal.
- .7 Primers: to manufacturer's recommendation for specific material, substrate and end use.
- .8 Water (if applicable): potable, clean and free from injurious amounts of deleterious substances.
- .9 Damming and buck up materials, supports and anchoring devices: to manufacturer's recommendations, and in accordance with tested assembly being installed as acceptable to authorities have jurisdiction.
- .10 Sealants for Vertical Joints: non-sagging.

2.2 ACCEPTABLE MATERIALS

- .1 Products of the following manufacturers are acceptable subject to conformance of the requirements of the Drawings, Schedules and Specifications:
 - .1 3M Fire Protection Products
 - .2 Ad Fire Protection Systems Inc
 - .3 Hilti Canada Corporation
 - .4 Tremco (Canada) Ltd
 - .5 Dow Corning Corporation

Part 3 Execution

3.1 MANUFACTURER'S INSTRUCTION

- .1 Compliance: comply with manufacturer's written specifications or recommendations, including product technical bulletins, handling, storage and installation instructions.

3.2 EXAMINATION

- .1 Verify substrate and surfaces are under which firestop is to be installed. Notify consultant in writing of any conditions not acceptable for installation. Installation of firestop implies acceptance of installed substrate.

3.3 PREPARATION

- .1 Examine sizes and conditions of voids to be filled to establish correct thicknesses and installation of material
 - .1 Ensure that substrates and surfaces are clean, dry and frost free.
 - .2 Do not apply fire stop material to surfaces previously painted or treated with sealers, curing compounds, water repellants or other coatings unless test have been performed to ensure compatibility of materials. Remove coatings as required.
- .2 Prepare & prime surfaces in accordance with manufacturer's written instructions.
- .3 Maintain insulation around pipes and ducts penetrating fire separations without interruption to vapour barrier.
- .4 Mask where necessary to avoid spillage and over coating onto adjoining surfaces; remove stains on adjacent surfaces.
- .5 Ensure that anchorage devices, clips, sleeves, supports, back-up materials and other related materials have been approved in the actual fire tests provided.

3.4 INSTALLATION

- .1 Install fire stopping and smoke seal material and components in accordance with manufacturer's certified tested system listing for type of material and condition of openings in each case.
- .2 Seal holes or voids made by through penetrations, poke-through termination devices, and unpenetrated openings or joints to ensure continuity and integrity of fire separation are maintained.
- .3 Provide temporary forming as required and remove forming only after materials have gained sufficient strength and after initial curing.
- .4 Tool or trowel exposed surfaces to neat finish.
- .5 Remove excess compound promptly as work progresses and upon completion.
- .6 Remove excess firestopping material promptly as work progresses and upon completion. Provide leak-proof dams as required to seal opening and contain firestop until cured.

3.5 SEQUENCE OF OPERATION

- .1 Proceed with installation only when submittals have been reviewed by consultant.
- .2 Install floor fire stopping before interior partition erections.

- .3 Metal deck bonding: fire stopping to precede spray applied fireproofing to ensure required bonding.
- .5 Ensure pipe insulation installation precedes fire stopping.

3.6 FIELD QUALITY CONTROL

- .1 Inspections: notify Consultant when ready for inspection and prior to concealing or enclosing fire stopping materials and service penetration assemblies.
- .2 Schedule site visits, to review work, as per Part 1 of this section.

3.7 CLEANING

- .1 Proceed in accordance with Section 01 74 11 Cleaning
- .2 On completion and verification of performance of installation, remove surplus material, excess materials, rubbish, tool and equipment.
- .3 Remove temporary dams after initial set of fire stopping and smoke seal material.

3.8 SCHEDULE

- .1 Fire stop and smoke seal at:
 - .1 Penetrations through fire-resistance rated masonry, concrete, and gypsum board partitions and walls.
 - .2 Edge of floor slabs at curtain wall and precast concrete panels.
 - .3 Top of fire-resistance rated masonry and gypsum board partitions.
 - .4 Intersection of fire-resistance rated masonry and gypsum board partitions.
 - .5 Control and sway joints in fire-resistance rated masonry and gypsum board partitions and walls.
 - .6 Penetrations through fire-resistance rated floor slabs, ceilings and roofs.
 - .7 Openings and sleeves installed for future use through fire separations.
 - .8 Around mechanical and electrical assemblies penetrating fire separations.
 - .9 Rigid ducts: greater than 129 cm²: fire stopping to consist of bead of fire stopping material between retaining angle and fire separation and between retaining angle and duct, on each side of fire separation.

END OF SECTION

Part 1 General

1.1 SECTION INCLUDES

- .1 Materials, preparation and application for caulking and sealants.

1.2 REFERENCES

- .1 American Society for Testing and Materials International, (ASTM)
 - .1 ASTM C919, Standard Practice for Use of Sealants in Acoustical Applications.
- .2 Canadian General Standards Board (CGSB)
 - .1 CAN/CGSB-19.13, Sealing Compound, One-component, Elastomeric, Chemical Curing.
- .3 Health Canada/Workplace Hazardous Materials Information System (WHMIS)
 - .1 Material Safety Data Sheets (MSDS).

1.3 SUBMITTALS

- .1 Submit manufacturer's literature in accordance with Section 01 13 30 Submittals to describe.
 - .1 Caulking compound.
 - .2 Primers.
 - .3 Sealing compound, each type, including compatibility when different sealants are in contact with each other.
 - .4 Installation instructions, surface preparation and product limitations.
- .2 Submit duplicate samples of each type of material and colour.
- .3 Cured samples of exposed sealants for each color where required to match adjacent material.
- .4 Manufacturers' instructions to include installation instructions for each product used.

1.4 DELIVERY, STORAGE, AND HANDLING

- .1 Deliver, handle, store and protect materials in accordance with Section 01 61 00 - Common Product Requirements.
- .2 Deliver and store materials in original wrappings and containers with manufacturer's seals and labels, intact. Protect from freezing, moisture, water and contact with ground or floor.

1.5 PROJECT CONDITIONS

- .1 Environmental Limitations:
 - .1 Do not proceed with installation of joint sealants under following conditions:
 - .2 When ambient and substrate temperature conditions are outside limits permitted by joint sealant manufacturer or are below 4.4°C.
 - .3 When joint substrates are wet.
- .2 Joint-Width Conditions:
 - .1 Do not proceed with installation of joint sealants where joint widths are less than those allowed by joint sealant manufacturer for applications indicated.
- .3 Joint-Substrate Conditions:
 - .1 Do not proceed with installation of joint sealants until contaminants capable of interfering with adhesion are removed from joint substrates.

Part 2 Products

2.1 SEALANT MATERIALS - GENERAL

- .1 Sealants and Caulking compounds must:
 - .1 Meet or exceed all applicable governmental and industrial safety and performance standards; and

- .2 Be manufactured and transported in such a manner that all steps of the process, including the disposal of waste products arising therefrom, will meet the requirements of all applicable governmental acts, by laws and regulations including, for facilities located in Canada, the Fisheries Act and the Canadian Environmental Protection Act (CEPA).
- .3 Sealant and caulking compounds must not be formulated or manufactured with: aromatic solvents, fibrous talc or asbestos, formaldehyde, halogenated solvents, mercury, lead, cadmium, hexavalent chromium, barium or their compounds, except barium sulphate.
- .4 Sealant and caulking compounds must not contain a total of volatile organic compound (VOC's) in excess of 5% by weight as calculated from records of the amounts of constituents used to make the product.
- .5 Sealant and caulking compounds must be accompanied by detailed instructions for proper application so as to minimize health concerns and maximize performance, and information describing proper disposal methods.
- .6 Do not use caulking that emits strong odours, contains toxic chemicals or is not certified as mould resistant in air handling units.
- .7 When low toxicity caulks are not possible, confine usage to areas which off-gas to exterior, are contained behind air barriers, or are applied several months before occupancy to maximize off-gas time.
- .8 Where sealants are qualified with primers use only these primers.
- .9 Sealants acceptable for use on this project must be listed on CGSB Qualified Products List issued by CGSB Qualification Board for Joint Sealants. Where sealants are qualified with primers use only these primers.

2.2

SEALANT MATERIALS

- .1 Sealant Type 1: Multi-component, polyepoxide urethane sealant. To meet specified requirements of CAN/CGSB-19.24-M90, Type 2, Class B. DYmeric 240FC by Tremco Ltd, or approved alternate.
- .2 Sealant Type 2: Mildew resistant, one component neutral cure silicone sealant meeting the specified requirements of CAN/CGSB-19GP22M. Tremsil 200 White by Tremco Ltd., Dow Corning 786 by Dow Corning Corporation, Silicone Sanitary Sealant by GE Canada or approved alternate.
- .3 Sealant Type 3: One component, non-skinning, non-hardening acoustical sealant meeting the specified requirements of CAN/CGSB-19.21-M87. Acoustical Sealant by Tremco Ltd.
- .4 Sealant Type 4: One component, paintable acrylic latex sealant meeting the specified requirements of specification CGSB-19-GP-17M. Tremflex 834 by Tremco Ltd. or approved alternate.
- .5 Sealant Type 5: Multi-component or single component self leveling or slope grade polyurethane sealant. Meeting the specified requirements of ASTM C920, Type M, Grade P, Class 25, Use T, M, A and O. Vulkem 45SSL polyurethane by Tremco Ltd, or approved alternate.
- .6 Primer: as recommended by Sealant Manufacturer.
- .7 Preformed Compressible and Non-Compressible back-up materials.
 - .1 Polyethylene, Urethane, Neoprene or Vinyl Foam.
 - .1 Extruded closed cell foam backer rod.
 - .2 Size: oversize 30 to 50 %.
 - .2 Neoprene or Butyl Rubber.
 - .1 Round solid rod, Shore A hardness 70.
 - .3 High Density Foam.
 - .1 Extruded closed cell polyvinyl chloride (PVC), extruded polyethylene, closed cell, Shore A hardness 20, tensile strength 140 to 200 kPa, extruded polyolefin foam, 32 kg/m³ density, or neoprene foam backer, size as recommended by manufacturer.

- .4 Bond Breaker Tape.
 - .1 Polyethylene bond breaker tape which will not bond to sealant.

2.3 JOINT CLEANER

- .1 Non-corrosive and non-staining type, compatible with joint forming materials and sealant recommended by sealant manufacturer.
- .2 Primer: as recommended by manufacturer.

Part 3 Execution

3.1 PROTECTION

- .1 Protect installed Work of other trades from staining or contamination.

3.2 SURFACE PREPARATION

- .1 Examine joint sizes and conditions to establish correct depth to width relationship for installation of backup materials and sealants.
- .2 Clean bonding joint surfaces of harmful matter substances including dust, rust, oil grease, and other matter which may impair work.
- .3 Do not apply sealants to joint surfaces treated with sealer, curing compound, water repellent, or other coatings unless tests have been performed to ensure compatibility of materials. Remove coatings as required.
- .4 Ensure joint surfaces are dry and frost free.
- .5 Prepare surfaces in accordance with manufacturer's directions.

3.3 PRIMING

- .1 Where necessary to prevent staining, mask adjacent surfaces prior to priming and caulking.
- .2 Prime sides of joints in accordance with sealant manufacturer's instructions immediately prior to caulking.

3.4 BACKUP MATERIAL

Apply bond breaker tape where required to manufacturer's instructions.
Install joint filler to achieve correct joint depth and shape, with approximately 30% compression.

3.5 MIXING

Mix materials in strict accordance with sealant manufacturer's instructions.

3.6 SEALANT APPLICATION

- .1 Apply sealant in accordance with manufacturer's written instructions.
- .2 Mask edges of joint where irregular surface or sensitive joint border exists to provide neat joint.
- .3 Apply sealant in continuous beads.
- .4 Apply sealant using gun with proper size nozzle.
- .5 Use sufficient pressure to fill voids and joints solid.
- .6 Form surface of sealant with full bead, smooth, free from ridges, wrinkles, sags, air pockets, embedded impurities.
- .7 Tool exposed surfaces before skinning begins to give slightly concave shape.
- .8 Remove excess compound promptly as work progresses and upon completion.
- .9 Curing.
 - .1 Cure sealants in accordance with sealant manufacturer's instructions.
 - .2 Do not cover up sealants until proper curing has taken place.
- .10 Cleanup.
 - .1 Clean adjacent surfaces immediately and leave Work neat and clean.
 - .2 Remove excess and droppings, using recommended cleaners as work progresses.

- .3 Remove masking tape after initial set of sealant.

3.1 SEALANT SCHEDULE

- .1 Seal all interior and exterior joints including joints indicated on Drawings and not specified herein, with Sealant Type 1; unless indicated otherwise with another Sealant Type.
- .2 Sealant Type 1, shall be used in the following locations:
 - .1 Perimeter joints of exterior hollow metal door and screen frames and louvre frames.
 - .2 Exposed control joints in masonry walls.
 - .3 Caulking in conjunction with flashing and sheet metal.
 - .4 Caulking and sealing full length of all exterior thresholds. All exterior doors will have thresholds.
 - .5 Interior and exterior perimeter caulking and internal window frame caulking of metal windows.
- .3 Sealant Type 2 shall be used in the following locations:
 - .1 Perimeter of plumbing fixtures (eg sinks, urinals, waterclosets, basins, vanities)
- .4 Sealant Type 3 shall be used in the following locations:
 - .1 Joints in conjunction with Metal Studs.
- .5 Sealant Type 4 shall be used in the following locations:
 - .1 All joints between interior hollow metal frames and surrounding material at all locations.
 - .2 Joints in conjunction with Gypsum Wall Board.
- .6 Sealant Type 5 shall be used in the following locations:
 - .1 Control joints and expansion joints in ceramic and porcelain tile (quarry tile) floors. Apply sealant full depth of tile up to 1/2" deep. If tile is installed over concrete slab, provide bond breaker tape beneath sealant.

End Of Section

Part 1 General

1.1 RELATED SECTIONS

- .1 Rough Carpentry: Section 06 10 00
- .2 Finish Hardware: Section 08 71 00

1.2 REFERENCES

- .1 American Society for Testing and Materials International (ASTM)
 - .1 ASTM A653/A653M-06a, Specification for Steel Sheet, Zinc-Coated (Galvanized) or Zinc-Iron Alloy-Coated (Galvannealed) by the Hot-Dip Process.
 - .2 ASTM B29-03, Standard Specification for Refined Lead.
 - .3 ASTM B749-03, Standard Specification for Lead and Lead Alloy Strip, Sheet and Plate Products.
- .2 Canadian General Standards Board (CGSB)
 - .1 CAN/CGSB-1.181-99, Ready-Mixed Organic Zinc-Rich Coating.
 - .2 CGSB 41-GP-19Ma-84, Rigid Vinyl Extrusions for Windows and Doors.
- .3 Canadian Standards Association (CSA International)
 - .1 CSA-G40.20-04/G40.21-04, General Requirements for Rolled or Welded Structural Quality Steel/Structural Quality Steel.
 - .2 CSA W59-03, Welded Steel Construction (Metal Arc Welding).
- .4 Canadian Steel Door Manufacturers' Association (CSDMA)
 - .1 CSDMA, Recommended Specifications for Commercial Steel Doors and Frames, 2000.
 - .2 CSDMA, Selection and Usage Guide for Commercial Steel Doors, 1990.
- .5 Underwriters' Laboratories of Canada (ULC)
 - .1 CAN/ULC-S704-03, Standard for Thermal Insulation, Polyurethane and Polyisocyanurate Boards, Faced.
 - .2 CAN4-S104-M80, Standard Method for Fire Tests of Door Assemblies.
 - .3 CAN4-S105-M85, Standard Specification for Fire Door Frames Meeting the Performance Required by CAN4-S104.

1.3 SYSTEM DESCRIPTION

- .1 Design Requirements:
 - .1 Design exterior frame assembly to accommodate to expansion and contraction when subjected to minimum and maximum surface temperature of -35 degrees C to 35 degrees C.
 - .2 Maximum deflection for exterior steel entrance screens under wind load of 1.2 kPa not to exceed 1/175th of span.
 - .3 Steel fire rated doors and frames: labelled and listed by an organization accredited by Standards Council of Canada in conformance with CAN4-S104 for ratings specified or indicated.
 - .4 Provide fire labelled frames for openings requiring fire protection ratings. Test products in conformance with CAN4-S104, ASTM E152 or NFPA 252 and listed by nationally recognized agency having factory inspection services.

1.4 SUBMITTALS

- .1 Provide submittals and product data in accordance with Section 01 33 00 - Submittal Procedures.
- .2 Provide shop drawings: in accordance with Section 01 33 00 - Submittal Procedures.
 - .1 Indicate each type of door, material, steel core thicknesses, mortises, reinforcements, location of exposed fasteners, openings, arrangement of hardware and fire rating and finishes.
 - .2 Indicate each type frame material, core thickness, reinforcements, location of anchors and exposed fastenings and reinforcing finishes.

- .3 Include schedule identifying each unit, with door marks and numbers relating to numbering on drawings and door schedule.
- .4 Submit test and engineering data, and installation instructions.

1.5 DELIVERY, STORAGE AND HANDLING

- .1 Deliver, store and handle materials in accordance with Section 01 61 00 - Common Product Requirements.
- .2 Waste Management and Disposal:
 - .1 Separate waste materials for reuse and recycling.

Part 2 Products

2.1 MATERIALS

- .1 Hot dipped galvanized steel sheet: to ASTM A653M, ZF75, minimum base steel thickness in accordance with CSDMA Table 1 - Thickness for Component Parts.
- .2 Reinforcement channel: to CSA G40.20/G40.21, Type 44W, coating designation to ASTM A653M, ZF75.

2.2 ADHESIVES

- .1 Honeycomb cores and steel components: heat resistant, spray grade, resin reinforced neoprene/rubber (polychloroprene) based, low viscosity, contact cement.
- .2 Polyurethane cores: heat resistant, epoxy resin based, low viscosity, contact cement.

2.3 PRIMER

- .1 Touch-up prime CAN/CGSB-1.181.

2.4 PAINT

- .1 Field paint steel doors and frames in accordance with Section 09 90 00 Painting. Protect weatherstrips from paint. Provide final finish free of scratches or other blemishes.

2.5 ACCESSORIES

- .1 Door silencers: single stud rubber/neoprene type.
- .2 Exterior top caps: steel.
- .3 Metallic paste filler: to manufacturer's standard.
- .4 Fire labels: metal riveted.
- .5 Sealant: in accordance with Section 07 90 00

2.6 FRAMES FABRICATION GENERAL

- .1 Fabricate frames in accordance with CSDMA specifications.
- .2 Fabricate frames to profiles and maximum face sizes as indicated.
- .3 Exterior frames: 16 ga (1.2 mm) welded type construction.
- .4 Interior frames: 16 (1.6 mm) welded or slip-on type construction. Refer to drawings for locations.
- .5 Blank, reinforce, drill and tap frames for mortised, templated hardware, and electronic hardware using templates provided by finish hardware supplier. Reinforce frames for surface mounted hardware.
- .6 Protect mortised cutouts with steel guard boxes.
- .7 Prepare frame for door silencers, 3 for single door, 2 at head for double door.
- .8 Manufacturer's nameplates on frames and screens are not permitted.
- .9 Conceal fastenings except where exposed fastenings are indicated.
- .10 Provide factory-applied touch up primer at areas where zinc coating has been removed during fabrication.
- .11 Insulate exterior frame components with polyurethane insulation.

2.7 FRAME ANCHORAGE

- .1 Provide appropriate anchorage to floor and wall construction.
- .2 Locate each wall anchor immediately above or below each hinge reinforcement on hinge jamb and directly opposite on strike jamb.
- .3 Provide 2 anchors for rebate opening heights up to 1520 mm and 1 additional anchor for each additional 760 mm of height or fraction thereof.
- .4 Locate anchors for frames in existing openings not more than 150 mm from top and bottom of each jambs and intermediate at 660 mm on centre maximum.

2.8 DOOR FABRICATION GENERAL

- .1 Doors: swing type, flush, with provision for glass and/or louvre openings as indicated.
- .2 Exterior doors: Polyurethane Core. Interior doors: honeycomb construction.
- .3 Fabricate doors with longitudinal edges locked seam. Seams: visible.
- .4 Blank, reinforce, drill doors and tap for mortised, template hardware.
- .5 Factory prepare holes 12.7 mm diameter and larger except mounting and through-bolt holes, on site, at time of hardware installation.
- .6 Reinforce doors where required, for surface mounted hardware. Provide flush steel top caps to exterior doors. Provide inverted, recessed, spot welded channels to top and bottom of interior doors.
- .7 Provide factory-applied touch-up primer at areas where zinc coating has been removed during fabrication.
- .8 Provide fire labelled doors for those openings requiring fire protection ratings, as scheduled. Test such products in conformance with CAN4-S104 and list by nationally recognized agency having factory inspection service and construct as detailed in Follow-Up Service Procedures/Factory Inspection Manuals issued by listing agency to individual manufacturers.
- .9 Manufacturer's nameplates on doors are not permitted.

2.9 DOORS: CORE CONSTRUCTION

- .1 Form face sheets for exterior doors from 16 ga (1.2 mm) sheet steel with polyurethane core laminated under pressure to face sheets.
- .2 Form face sheets for interior doors from 18 ga. (1.0 mm) sheet steel with honeycomb core laminated under pressure to face sheets.

Part 3 Execution

3.1 MANUFACTURER'S INSTRUCTIONS

- .1 Compliance: comply with manufacturer's written recommendations or specifications, including product technical bulletins, handling, storage and installation instructions, and datasheets.

3.2 INSTALLATION GENERAL

- .1 Install labelled steel fire rated doors and frames to NFPA 80 except where specified otherwise.
- .2 Install doors and frames to CSDMA Installation Guide.

3.3 FRAME INSTALLATION

- .1 Set frames plumb, square, level and at correct elevation.
- .2 Secure anchorages and connections to adjacent construction.
- .3 Brace frames rigidly in position while building-in. Install temporary horizontal wood spreader at third points of door opening to maintain frame width. Provide vertical support at centre of head for openings over 1200 mm wide. Remove temporary spreaders after frames are built-in.
- .4 Make allowances for deflection of structure to ensure structural loads are not transmitted to frames.

- .5 Caulk perimeter of frames between frame and adjacent material.
- .6 Install transition strip air barrier at perimeter of all frames.

3.4 DOOR INSTALLATION

- .1 Install doors and hardware in accordance with hardware templates and manufacturer's instructions and Section 08 71 00 - Door Hardware.
- .2 Provide even margins between doors and jambs and doors and finished floor as follows.
 - .1 Hinge side: 1.0 mm.
 - .2 Latchside and head: 1.5 mm.
 - .3 Finished floor, top of carpet and thresholds: 13 mm.
- .3 Adjust operable parts for correct function.

3.5 FINISH REPAIRS

- .1 Touch up with primer finishes damaged during installation.
- .2 Fill exposed frame anchors and surfaces with imperfections with metallic paste filler and sand to a uniform smooth finish.

End Of Section

Part 1 General

1.1 RELATED WORK

- .1 Metal Doors and Frames: Section 08 11 00

1.2 MAINTENANCE DATA

- .1 Provide operation and maintenance data for door closers, locksets, door holders and fire exit hardware for incorporation into manual specified in Section 01 77 00 Closeout Submittals
- .2 Brief maintenance staff regarding proper care, cleaning, and general maintenance.

1.3 MAINTENANCE MATERIALS

- .1 Provide maintenance materials in accordance with Section 01 78 00 Closeout Submittals
- .2 Supply two sets of wrenches for door closers, locksets and fire exit hardware.

1.4 DELIVERY AND STORAGE

- .1 Store finishing hardware in locked, clean and dry area.
- .2 Package each item of hardware including fastenings, separately or in like groups of hardware, label each package as to item definition and location.

Part 2 Products

2.1 HARDWARE ITEMS

- .1 Hardware items shall be in accordance with the following:
 - .1 Contactor to supply and install:
**HES Electric strike,(HES 1600), 630,
Door operator HA-8P-2 41 CLEAR RH/ PULL,
Universal washroom kit CX-WEC10,
Restroom Control kit CX WC13XSM,
Power supply PS902,**
 - .2 Owner supplied, Contactor install:
Hinges
 - .3 Owner supplied and install:
**Locksets
Kick plates
Keying**

Part 3 Execution

3.1 INSTALLATION INSTRUCTIONS

- .1 Obtain manufacturer's instructions for proper installation of each hardware component.
- .2 Examine all work to receive finishing hardware when ready and report any unsuitable condition to the Consultant prior to continuing.
- .3 Where door stop contacts door pulls, mount stop to strike bottom of pull.
- .4 Remove and reinstall new and existing hardware as necessary to allow finish painting.
- .5 All work shall be installed plumb and true and secured with proper fastenings.

END OF SECTION

Part 1 General

1.1 RELATED REQUIREMENTS

- .1 Section 07 21 16: Blanket Insulation
- .2 Section 09 22 16: Non-Structural Metal Framing
- .3 Section 09 90 00: Painting

1.2 REFERENCES

- .1 ASTM International
 - .1 ASTM C475-02(2007), Standard Specification for Joint Compound and Joint Tape for Finishing Gypsum Board.
 - .2 ASTM C840-08, Standard Specification for Application and Finishing of Gypsum Board.
 - .3 ASTM C1002-07, Standard Specification for Steel Self-Piercing Tapping Screws for the Application of Gypsum Panel Products or Metal Plaster Bases to Wood Studs or Steel Studs.
 - .4 ASTM C1280-99, Standard Specification for Application of Gypsum Sheathing.
 - .5 ASTM C1396/C1396M-09a, Standard Specification for Gypsum Wallboard.
- .2 Underwriters' Laboratories of Canada (ULC)
 - .1 CAN/ULC-S102-07, Standard Method of Test of Surface Burning Characteristics of Building Materials and Assemblies.

1.3 ACTION AND INFORMATIONAL SUBMITTALS

- .1 Submit in accordance with Section 01 33 00 - Submittal Procedures.
- .2 Product Data:
 - .1 Submit manufacturer's instructions, printed product literature and data sheets for gypsum board assemblies and include product characteristics, performance criteria, physical size, finish and limitations.

1.4 DELIVERY, STORAGE AND HANDLING

- .1 Deliver, store and handle materials in accordance with manufacturer's written instructions.
- .2 Delivery and Acceptance Requirements: deliver materials to site in original factory packaging, labelled with manufacturer's name and address.
- .3 Storage and Handling Requirements:
 - .1 Store gypsum board assemblies materials level in accordance with manufacturer's recommendations in clean, dry, well-ventilated area.
 - .2 Store and protect gypsum board assemblies from nicks, scratches, and blemishes.
 - .3 Protect from weather, elements and damage from construction operations.
 - .4 Handle gypsum boards to prevent damage to edges, ends or surfaces.
 - .5 Replace defective or damaged materials with new.
- .4 Packaging Waste Management: remove for reuse of pallets, crates, padding, packaging materials.

1.5 AMBIENT CONDITIONS

- .1 Maintain temperature 10 degrees C minimum, 21 degrees C maximum for 48 hours prior to and during application of gypsum boards and joint treatment, and for 48 hours minimum after completion of joint treatment.
- .2 Apply board and joint treatment to dry, frost free surfaces.
- .3 Ventilation: ventilate building spaces as required to remove excess moisture that would prevent drying of joint treatment material immediately after its application.

Part 2 Products

2.1 MATERIALS

- .1 Standard board: to ASTM C1396/C1396M regular, 5/8" (16 mm) thick, Type X, 1/2" (12 mm) thick, 1200 mm wide x maximum practical length, ends square cut, edges bevelled.
- .2 Glass mat water-resistant gypsum backing board: to ASTM C1178/C1178M, thickness as indicated, 4'-0" (1200 mm) wide x maximum practical length.
- .3 Metal furring runners, hangers, tie wires, inserts, anchors: manufacturer's standard.
- .4 Drywall furring channels: 0.5 mm core thickness galvanized steel channels for screw attachment of gypsum board.
- .5 Steel drill screws: to ASTM C1002.
- .6 Casing beads, corner beads, control joints and edge trim: to ASTM C1047, zinc-coated by hot-dip process, 0.5 mm base thickness, perforated flanges, one piece length per location.
- .7 Sealants: in accordance with Section 07 90 00 - Joint Sealants.
 - .1 Acoustic sealant: in accordance with Section 07 90 00 - Joint Sealants.
- .8 Insulating strip: rubberized, moisture resistant, 1/8" (3 mm) thick cork or closed cell neoprene strip, 1/2" (12 mm) wide, with self sticking permanent adhesive on one face, lengths as required.
- .9 Joint compound: to ASTM C475, asbestos-free.

Part 3 Execution

3.1 EXAMINATION

- .1 Verification of Conditions: verify conditions of substrates previously installed under other Sections or Contracts are acceptable for gypsum board assemblies installation in accordance with manufacturer's written instructions.
 - .1 Visually inspect substrate in presence of Consultant, inform Consultant of unacceptable conditions immediately upon discovery. Beginning installations means acceptance of existing conditions.

3.2 ERECTION

- .1 Do application and finishing of gypsum board to ASTM C840 except where specified otherwise.
- .2 Do application of gypsum sheathing to ASTM C1280.
- .3 Erect hangers and runner channels for suspended gypsum board ceilings to ASTM C840 except where specified otherwise.
- .4 Support light fixtures by providing additional ceiling suspension hangers within 6" (150 mm) of each corner and at maximum 24" (600 mm) around perimeter of fixture.
- .5 Install work level to tolerance of 1:1200.
- .6 Frame with furring channels, perimeter of openings for access panels, light fixtures, diffusers, grilles.
- .7 Install 3/4" X 2 1/2" (19 x 64 mm) furring channels parallel to, and at exact locations of steel stud partition header track.
- .8 Furr for gypsum board faced vertical bulkheads within and at termination of ceilings.
- .9 Furr above suspended ceilings for gypsum board fire and sound stops and to form plenum areas as indicated.
- .10 Install wall furring for gypsum board wall finishes to ASTM C840, except where specified otherwise.
- .11 Furr openings and around built-in equipment, cabinets, access panels, on four sides. Check clearances with equipment suppliers.
- .12 Furr duct shafts, beams, columns, pipes and exposed services where indicated.

3.3 APPLICATION

- .1 Apply gypsum board after bucks, anchors, blocking, sound attenuation, electrical and mechanical work have been approved.
- .2 Apply single layer gypsum board to metal furring or framing using screw fasteners. Maximum spacing of screws 12" (300 mm) on centre].
 - .1 Single-Layer Application:
 - .1 Apply gypsum board on ceilings prior to application of walls to ASTM C840.
 - .2 Apply gypsum board vertically or horizontally, providing sheet lengths that will minimize end joints.
- .3 Apply water-resistant gypsum board where indicated. Apply water-resistant sealant to edges, ends, cut-outs which expose gypsum core and to fastener heads.
- .4 Apply Tile Backer Board where indicated in accordance with manufacturer's instructions.
- .5 Apply ½" (12 mm) diameter bead of acoustic sealant continuously around periphery of each face of partitioning to seal gypsum board/structure junction where partitions abut fixed building components. Seal full perimeter of cut-outs around electrical boxes, ducts, in partitions where perimeter sealed with acoustic sealant.
- .6 Install ceiling boards in direction that will minimize number of end-butt joints. Stagger end joints at least 10" (250 mm).
- .7 Install gypsum board on walls vertically to avoid end-butt joints.
- .8 Install gypsum board with face side out.
- .9 Do not install damaged or damp boards.
- .10 Locate edge or end joints over supports. Stagger vertical joints over different studs on opposite sides of wall.

3.4 INSTALLATION

- .1 Erect accessories straight, plumb or level, rigid and at proper plane. Use full length pieces where practical. Make joints tight, accurately aligned and rigidly secured. Mitre and fit corners accurately, free from rough edges. Secure in accordance with manufacturer's instructions.
- .2 Install casing beads around perimeter of suspended ceilings.
- .3 Install casing beads where gypsum board butts against surfaces having no trim concealing junction and where indicated. Seal joints with sealant.
- .4 Install insulating strips continuously at edges of gypsum board and casing beads abutting metal window and exterior door frames, to provide thermal break.
- .5 Construct control joints of two back-to-back casing beads set in gypsum board facing and supported independently on both sides of joint.
- .6 Provide continuous polyethylene dust barrier behind and across control joints.
- .7 Locate control joints at changes in substrate construction or at approximate 30'-0" (10 m) spacing on long corridor runs and at approximate 45'-0" (15 m) spacing on ceilings].
- .8 Install control joints straight and true.
- .9 Install expansion joint straight and true.
- .10 Splice corners and intersections together and secure to each member with 3 screws.
- .11 Install access doors to electrical and mechanical fixtures specified in respective sections.
 - .1 Rigidly secure frames to furring or framing systems.
- .12 Finish face panel joints and internal angles with joint system consisting of joint compound, joint tape and taping compound installed according to manufacturer's directions and feathered out onto panel faces.
- .13 Gypsum Board Finish: finish gypsum board walls and ceilings to following levels in accordance with AWCI Levels of Gypsum Board Finish:
 - .1 Levels of finish:
 - .1 Level 4: embed tape for joints and interior angles in joint compound and apply three separate coats of joint compound over joints, angles, fastener heads and accessories; surfaces smooth and free of tool marks and ridges.

- .14 Finish corner beads, control joints and trim as required with two coats of joint compound and one coat of taping compound, feathered out onto panel faces.
- .15 Fill screw head depressions with joint and taping compounds to bring flush with adjacent surface of gypsum board so as to be invisible after surface finish is completed.
- .16 Sand lightly to remove burred edges and other imperfections. Avoid sanding adjacent surface of board.
- .17 Completed installation to be smooth, level or plumb, free from waves and other defects and ready for surface finish.

3.5

CLEANING

- .1 Progress Cleaning: clean in accordance with Section 01 74 11 - Cleaning.
 - .1 Leave Work area clean at end of each day.
 - .2 Final Cleaning: upon completion remove surplus materials, rubbish, tools and equipment in accordance with Section 01 74 11 - Cleaning.
- .2 Waste Management: separate waste materials for reuse or recycling.
 - .1 Remove recycling containers and bins from site and dispose of materials at appropriate facility.

3.6

PROTECTION

- .1 Protect installed products and components from damage during construction.
- .2 Repair damage to adjacent materials caused by gypsum board assemblies installation.

End Of Section

Part 1 General

1.1 RELATED REQUIREMENTS

- .1 Section 07 21 16: Blanket Insulation
- .2 Section 09 21 16 Gypsum Board.
- .3 Section 09 90 00 Painting.

1.2 REFERENCES

- .1 ASTM International
 - .1 ASTM C645-11a, Standard Specification for Non-structural Steel Framing Members.
 - .2 ASTM C754-11, Standard Specification for Installation of Steel Framing Members to Receive Screw-Attached Gypsum Panel Products.

1.3 ACTION AND INFORMATIONAL SUBMITTALS

- .1 Submit in accordance with Section 01 33 00 - Submittal Procedures.
- .2 Product Data:
 - .1 Submit manufacturer's instructions, printed product literature and data sheets for metal framing and include product characteristics, performance criteria, physical size, finish and limitations.

1.4 QUALITY ASSURANCE

- .1 Test Reports: submit certified test reports showing compliance with specified performance characteristics and physical properties.
- .2 Certificates: submit product certificates signed by manufacturer certifying materials comply with specified performance characteristics and criteria and physical requirements.

1.5 DELIVERY, STORAGE AND HANDLING

- .1 Deliver, store and handle materials in accordance with manufacturer's written instructions.
- .2 Delivery and Acceptance Requirements: deliver materials to site in original factory packaging, labelled with manufacturer's name and address.
- .3 Storage and Handling Requirements:
 - .1 Store materials in accordance with manufacturer's recommendations in clean, dry, well-ventilated area.
 - .2 Store and protect metal framing from nicks, scratches, and blemishes.
 - .3 Replace defective or damaged materials with new.
- .4 Packaging Waste Management: remove for reuse of pallets, crates, padding, packaging materials.

Part 2 Products

2.1 MATERIALS

- .1 Non-load bearing channel stud framing: to ASTM C645, stud size as indicated, roll formed from 26 ga (0.45 mm) thickness hot dipped galvanized steel sheet, for screw attachment of gypsum board.
 - .1 Knock-out service holes at 18" (460 mm) centres.
- .2 Floor and ceiling tracks: to ASTM C645, in widths to suit stud sizes, 1¼" (32 mm) flange height.
- .3 Metal channel stiffener: cold rolled steel, coated with rust inhibitive coating.
- .4 Acoustical sealant: in accordance with Section 07 92 00 - Joint Sealants.
- .5 Insulating strip: rubberized, moisture resistant 1/8" (3 mm) thick cork or foam strip, ½" (12 mm) wide, with self sticking adhesive on one face, lengths as required.

Part 3 Execution

3.1 EXAMINATION

- .1 Verification of Conditions: verify that conditions of substrate previously installed under other Sections or Contracts are acceptable for non-structural metal framing application in accordance with manufacturer's written instructions.
 - .1 Visually inspect substrate in presence of Consultant, inform Consultant of unacceptable conditions immediately upon discovery, beginning work means acceptance of conditions.

3.2 ERECTION

- .1 Align partition tracks at floor and ceiling and secure at 24" (600 mm) on centre maximum.
- .2 Install damp proof course under stud shoe tracks of partitions on slabs on grade.
- .3 Place studs vertically at 16" (400 mm) on centre and not more than 2" (50 mm) from abutting walls, and at each side of openings and corners.
 - .1 Position studs in tracks at floor and ceiling. Cross brace steel studs as required to provide rigid installation to manufacturer's instructions.
- .4 Erect metal studding to tolerance of 1:1000.
- .5 Attach studs to bottom and ceiling track using screws.
- .6 Co-ordinate simultaneous erection of studs with installation of service lines. When erecting studs ensure web openings are aligned.
- .7 Co-ordinate erection of studs with installation of door/window frames and special supports or anchorage for work specified in other Sections.
- .8 Provide two studs extending from floor to ceiling at each side of openings wider than stud centres specified.
 - .1 Secure studs together, 2" (50 mm) apart using column clips or other approved means of fastening placed alongside frame anchor clips.
- .9 Install heavy gauge single jamb studs at openings.
- .10 Erect track at head of door/window openings and sills of sidelight/window openings to accommodate intermediate studs.
 - .1 Secure track to studs at each end, in accordance with manufacturer's instructions.
 - .2 Install intermediate studs above and below openings in same manner and spacing as wall studs.
- .11 Frame openings and around built-in equipment, cabinets, access panels, on four sides. Extend framing into reveals. Check clearances with equipment suppliers.
- .12 Provide 1 5/8" (40 mm) stud or furring channel secured between studs for attachment of fixtures behind lavatory basins, toilet and bathroom accessories, and other fixtures including grab bars and towel rails, attached to steel stud partitions.

- .13 Install steel studs or furring channel between studs for attaching electrical and other boxes.
- .14 Extend partitions to ceiling height except where noted otherwise on drawings.
- .15 Maintain clearance under beams and structural slabs to avoid transmission of structural loads to studs.
- .16 Install continuous insulating strips to isolate studs from uninsulated surfaces.
- .17 Install two continuous beads of acoustical sealant or insulating strip under studs and tracks around perimeter of sound control partitions.

3.3

CLEANING

- .1 Progress Cleaning: clean in accordance with Section 01 74 11 - Cleaning.
 - .1 Leave Work area clean at end of each day.
 - .2 Final Cleaning: upon completion remove surplus materials, rubbish, tools and equipment in accordance with Section 01 74 11 - Cleaning.
- .2 Waste Management: separate waste materials for reuse or recycling.
 - .1 Remove recycling containers and bins from site and dispose of materials at appropriate facility.

3.4

PROTECTION

- .1 Protect installed products and components from damage during construction.
- .2 Repair damage to adjacent materials caused by gypsum board assemblies installation.

End Of Section

Part 1 General

1.1 RELATED SECTIONS

- .1 Submittal Procedures: Section 01 33 00

1.2 REFERENCES

- .1 American Society for Testing and Materials International (ASTM)
 - .1 ASTM C635-00, Specifications for the Manufacture, Performance and Testing of Metal Suspension Systems for Acoustical Tile and Lay-In Panel Ceilings.
 - .2 ASTM C636-96, Practice for Installation of Metal Ceiling Suspension Systems for Acoustical Tile and Lay-In Panels.
 - .3 ASTM E1477-98a(2003), Standard Test Method for Luminous Reflectance Factor of Acoustical Materials by Use of Integrating-Sphere Reflectometers.
- .2 Canadian General Standards Board (CGSB)
 - .1 CAN/CGSB-92.1-M89, Sound Absorptive Prefabricated Acoustical Units.
- .3 Underwriters Laboratories of Canada (ULC)
 - .1 CAN/ULC-S102-2003, Surface Burning Characteristics of Building Materials and Assemblies.

1.3 SUBMITTALS

- .1 Submit samples in accordance with Section 01 33 00 - Submittal Procedures.
 - .1 Submit duplicate samples of acoustical units.
- .2 Submit ceiling grid manufacturer's certification that grid will support super-imposed loads, such as lighting fixtures diffusers, grilles and speakers.

1.4 DESIGN REQUIREMENTS

- .1 Maximum deflection: 1/360th of span to ASTM C635 deflection test.

1.5 STORAGE AND HANDLING

- .1 Store materials inside, level, under cover. Protect from weather, damage from construction operations and other causes, in accordance with manufacturer's printed instructions.
- .2 Handle materials to prevent damage to edges or surfaces. Protect metal accessories and trim from being bent or damaged.

Part 2 Products

2.1 ACOUSTICAL CEILING PANELS

- .1 Acoustic units for suspended ceiling system: to CAN/CGSB-92.1.
 - .1 ACT (CF1): 24" x 24" x 5/8" thick, square edge,
 - .1 Acceptable Product: CGC Radar,
 - .2 or approved alternate.

2.2 ACOUSTICAL SUSPENSION

- .1 Intermediate duty system to ASTM C635.
- .2 Basic materials for suspension system: commercial quality cold rolled steel, zinc coated.
- .3 Suspension system: non fire rated, two directional exposed tee bar grid.
- .4 Exposed tee bar grid components: shop painted satin sheen. Components die cut. Main tee with double web, rectangular bulb and nominal 1" (25 mm) rolled cap on exposed face. Cross tee with rectangular bulb; web extended to form positive interlock with main tee webs; lower flange extended and offset to provide flush intersection.
 - .1 Grid Colour for all areas: White
- .5 Hanger wire: galvanized soft annealed steel wire, 3.6 mm diameter for access tile ceilings.
- .6 Hanger inserts: purpose made.
- .7 Carrying channels: manufacturer's standard

- .8 Accessories: splices, clips, wire ties, retainers and wall moulding flush, to complement suspension system components, as recommended by system manufacturer.
- .9 Acceptable Product: CGC DX/DXL or approved alternate.

Part 3 Execution

3.1 INSTALLATION OF SUSPENSION SYSTEM

- .1 Installation: in accordance with ASTM C636 except where specified otherwise.
- .2 Do not erect ceiling suspension system until work above ceiling has been inspected by Consultant.
- .3 Secure hangers to overhead structure using attachment methods acceptable to Consultant.
- .4 Install hangers spaced at maximum 1200 mm centres and within 150 mm from ends of main tees.
- .5 Lay out centreline of ceiling both ways, according to reflected ceiling plan.
- .6 Install wall moulding to provide correct ceiling height.
- .7 Completed suspension system to support super-imposed loads, such as lighting fixtures, diffusers, grilles and speakers.
- .8 Support at light fixtures, diffusers with additional ceiling suspension hangers within 150 mm of each corner and at maximum 600 mm around perimeter of fixture.
- .9 Interlock cross member to main runner to provide rigid assembly.
- .10 Finished ceiling system to be square with adjoining walls and level within 1:1000.

3.2 INSTALLATION OF ACOUSTIC PANELS

- .1 Install acoustical panels and tiles in ceiling suspension system.
- .2 Co-ordinate ceiling work to accommodate components of other sections, such as light fixtures, diffusers, speakers, sprinkler heads, to be built into acoustical ceiling components.
- .3 Paint exposed edge of cut tiles.

End of section

Part 1 General

1.1 REFERENCES

- .1 American Society for Testing and Materials International (ASTM)
 - .1 ASTM F1303-[04], Standard Specification for Sheet Vinyl Floor Covering with Backing.
- .2 Health Canada/Workplace Hazardous Materials Information System (WHMIS)
 - .1 Material Safety Data Sheets (MSDS).

1.2 SUBMITTALS

- .1 Submit samples in accordance with Section 01 33 00 - Submittal Procedures.
 - .1 Submit samples of each type of flooring type.
 - .2 Submit base samples.
- .2 Product Data:
 - .1 Submit manufacturer's printed product literature, specifications and data sheet in accordance with Sections 01 33 00 - Submittal Procedures.

1.3 MAINTENANCE

- .1 Extra Materials:
 - .1 Provide maintenance materials in accordance with Section 01 78 00 - Closeout Submittals
 - .2 Provide minimum 2% of each type and colour of tile required for project for maintenance use. Store where directed.
 - .3 Maintenance material shall be same production run as installed material.

1.4 CLOSEOUT SUBMITTALS

- .1 Provide maintenance data for resilient flooring for incorporation into manual specified in Section 01 78 00 - Closeout Submittals.

1.5 ENVIRONMENTAL REQUIREMENTS

- .1 Provide a high ventilation rate, with maximum outside air, during installation, and for 48 to 72 hours after installation. If possible, vent directly to the outside. Do not let contaminated air recirculate through a district or whole building air distribution system.

Part 2 Products

2.1 RESILIENT TILE FLOORING MATERIALS

- .1 Vinyl composition tile: to ASTM F1066, Composition 1 - non asbestos Class 3 – colour through, plain, 1/8" x 12" x 12" (3 x 300 x 300 mm) size, Two (2) colours will be selected by consultant from manufacturer's standard range.

2.2 ACCESSORIES

- .1 Resilient base: continuous, top set, complete with premoulded end stops and external corners:
 - .1 Type: rubber, 1/8" (3.0 mm) thick.
 - .2 Style: cove.
 - .3 Height: 4" and 6", refer to drawings.
 - .4 Lengths: cut lengths minimum 8'-0" (2400 mm).
 - .5 Colour: selected by Consultant.
- .2 Primers and adhesives: of types recommended by resilient flooring manufacturer for specific material on applicable substrate, above, on or below grade.
- .3 Concrete Filler Mix: cement based underlayment mix, as recommended by flooring manufacturer. Ardex Feather Finish or approved alternate.

- .4 Metal edge strips: extruded aluminum, smooth, stainless steel with lip to extend under floor finish, shoulder flush with top of adjacent floor finish.
- .5 Sealer and wax: type recommended by resilient flooring material manufacturer for material type and location.
- .6 Moisture Barrier: solvent free, alkali resistant, low viscosity moisture barrier product.
- .7 .1 Acceptable product:
 - .1 Ardex MC Moisture control
 - .2 LiquiDam by Tec
 - .3 or approved alternate.
- .7 Metal edge strips: extruded aluminum, smooth, mill finish, with lip to extend under floor finish, shoulder flush with top of adjacent floor finish.
- .8 Fillet Strip: Fillet Strip: Johnsonite CFS-00 Cove Filler, 1-3/4" radius.
- .9 Self Levelling Materials for infill areas:
 - .1 Primer: acrylic latex base, compatible with Self Levelling Compound. Acceptable Product Tec Multipurpose Primer or approved alternate.
 - .2 Self Levelling Underlayment: cement based, pourable, pumpable, free flowing underlayment. Acceptable Product: Level Set 200 by Tec Self Leveling Underlayment or approved Alternate.

Part 3 Execution

3.1 SITE VERIFICATION OF CONDITIONS

- .1 Ensure concrete floors are clean and dry by using test methods recommended by flooring manufacturer.

3.2 PREPARATION

- .1 The recommendations of the manufacturer of the resilient floor covering will be considered as minimal.
- .2 Remove sub-floor ridges and bumps. Fill low spots, cracks, joints, holes and other defects with sub-floor filler.
- .3 Clean floor and apply filler; trowel and float to leave smooth, flat hard surface. Prohibit traffic until filler cured and dry.
- .4 Prime or Seal concrete slab and plywood sub-floor to resilient flooring manufacturer's printed instructions.

3.3 APPLICATION: FLOORING

- .1 Apply adhesive uniformly using recommended trowel. Do not spread more adhesive than can be covered by flooring before initial set takes place.
- .2 Resilient Tile:
 - .1 Lay flooring with joints parallel to building lines to produce symmetrical tile pattern. Border tiles minimum half tile width.
 - .2 Install square resilient tile flooring to square grid pattern with all joints aligned.
- .3 As installation progresses, and after installation roll flooring with 45 kg minimum roller to ensure full adhesion.
- .4 Cut flooring neatly around fixed objects.
- .5 Continue flooring over areas which will be under built-in furniture.
- .6 Terminate flooring at centreline of door in openings where adjacent floor finish or colour is dissimilar.
- .7 Install metal edge strips at unprotected or exposed edges where flooring terminates.

3.4 APPLICATION: BASE

- .1 Lay out base to keep number of joints at minimum.
- .2 Clean substrate and prime with one coat of adhesive.
- .3 Apply adhesive to back of base.
- .4 Set base against wall and floor surfaces tightly by using 3 kg hand roller.
- .5 Install straight and level to variation of 1:1000.
- .6 Scribe and fit to door frames and other obstructions. Use premoulded end pieces at flush door frames.
- .7 Cope internal corners. Use premoulded corner units for right angle external corners. Use formed straight base material for external corners of other angles.
- .8 Use coved type base in all areas.

3.5 CLEANING

- .1 Remove excess adhesive from floor, base and wall surfaces without damage.
- .2 Clean, seal and wax floor and base surface to flooring manufacturer's printed instructions. Apply minimum 2 coats wax to tile floors.

3.6 PROTECTION

- .1 Protect new floors in accordance with manufacturer's printed instructions.

End of section

Part 1 General

1.1 REFERENCES

- .1 Complete work to CSC Architectural Specifications Study on Terrazzo by the Terrazzo, Tile and Marble Association of Canada.

1.2 SUBMITTALS

- .1 Submittals in Accordance with Section 01 73 00, Submittals.
- .2 Manufacturer's product data for each type of terrazzo and accessory. Data to include the following:
 - .1 Physical Properties
 - .2 Performance properties
 - .3 Specified tests
 - .4 Material Safety Data Sheet
- .2 Shop Drawings: Include plans, elevations sections, component details and attachments to other work. Show layout of the following
 - .1 Divider Strips
 - .2 Control and expansion joint strips
 - .3 Base and Boarder strips
 - .4 Pre-cast terrazzo jointing and edge configuration including anchorage details
 - .5 Terrazzo patterns
- .3 Samples:
 - .1 Samples for initial selection from Terrazzo & Marble Supply color plates showing the full range of colors and patterns available for each terrazzo type indicated.
 - .2 Samples for Verification: Match architect's samples for each type, material, color and pattern of terrazzo and accessory required showing the full range of color, texture and pattern variations expected. Label each terrazzo sample to identify Terroxy Resin System's matrix color and aggregate types, sizes and proportions. Prepare samples of same thickness and from same material to be used for the work in size indicated below:
 - .1 Epoxy terrazzo: minimum 6" x 6" (152.4 mm x 152.4 mm) sample of each color and type of terrazzo.
 - .2 Precast epoxy terrazzo: minimum 6" x 6" (152.4 mm x 152.4 mm) sample of each color and type of terrazzo.
 - .3 Accessories: 6" length (152.4 mm) of each kind of divider strip, stop strip and control joint strip required.
 - .4 Pre-Cast Base
- .4 Manufacturer Experience:
 - .1 Submit proof of associate membership in NTMA.
 - .2 Furnish a list of at least five (5) epoxy terrazzo projects using material being submitted for this project installed during the last five (5) years of the same scope, complexity and at least 50 percent of the square footage.
 - .3 Engage an epoxy manufacturer with at least ten (10) years experience.
- .5 Qualification Data: For qualified installer.
 - .1 Submit proof of contractor membership in NTMA.
 - .2 Furnish a list of at least five (5) epoxy terrazzo projects using material being submitted for this project installed during the last five (5) years of the same scope, complexity and at least 50 percent of the square footage.
- .6 Material Test Reports: For moisture and/or relative humidity of substrate.

- .7 Maintenance Data: Submit 2 copies of NTMA maintenance recommendations and 2 copies of manufacturer's instructions.

1.3 QUALITY ASSURANCE

- .1 Installer Qualifications: A qualified installer who is acceptable to architect and epoxy terrazzo manufacturer to install manufacturer's products.
 - .1 Engage a terrazzo contractor with at least five (5) years of satisfactory experience in installation of epoxy terrazzo. Terrazzo contractor shall demonstrate experience during last five (5) years of at least five (5) projects of comparable scope and complexity of at least 50 percent of the total square footage of this project
 - .2 Engage an installer who is a contractor member of NTMA.
- .2 Source Limitations:
 - .1 Obtain primary Epoxy Terrazzo Flooring System materials including moisture treatment, membranes, primers, resins and hardening agents from a single manufacturer with proof of NTMA associate membership.
 - .2 Obtain aggregates, divider strips, sealers and cleaners from source recommended by primary materials manufacturer.
 - .3 Engage an epoxy manufacturer with at least ten (10) years experience as a NTMA associate member.
- .3 Pre-installation Conference: Conduct conference at project site to comply with requirements in Section 01 31 19 Project Meetings. Review methods and procedures related to terrazzo including, but not limited to, the following:
 - .1 Inspect and discuss installation procedures, joint details, job site conditions, substrate specification, vapor barrier details and coordination with other trades.
 - .2 Review and finalize construction schedule and verify availability of materials, installer's personnel, equipment and facilities needed to make progress and avoid delays.
 - .3 Review special terrazzo designs and patterns.
 - .4 Review plans for concrete curing and site drying to enable timely achievement of suitable slab moisture conditions.
- .4 NTMA Standards: Comply with NTMA's "Terrazzo Specifications and Design Guide" and with written recommendations for terrazzo type indicated unless more stringent requirements are specified.
- .5 Mock-ups: Build mock-ups to verify selections made under sample submittals and to demonstrate aesthetic effects and set quality standards for materials and execution.
 - .1 Build mock-ups for terrazzo including accessories of typical poured-in-place flooring condition for each color and pattern
 - .2 Approved mockups may become part of the completed work if undisturbed at time of substantial completion.

1.4 DELIVERY, STORAGE AND HANDLING

- .1 Deliver materials to project site in supplier's original wrappings and containers labeled with source's or manufacturer's name, material or product brand name and lot number if any.
- .2 Store materials in their original, undamaged packages and containers inside a well-ventilated area protected from weather, moisture, soiling, extreme temperatures and humidity.
 - .1 Storage temperatures should be between 50°F to 90°F (10.0°C to 32.2°C).

1.5 PROJECT CONDITIONS

- .1 Prior to surface preparation, terrazzo contractor shall:

- .1 Evaluate slab condition, including slab moisture content and extent of repairs required, if any.
- .2 Maintain the ambient room and floor temperature at 60-90°F (15.5-32.2°C) or above for a period extending 72 hours before, during and after floor installation. Concrete to receive epoxy terrazzo shall have cured for at least 28 days and be free of all curing compounds. Test concrete substrate to determine acceptable moisture levels prior to installation. Testing should be conducted according to ASTM F2170 (determining relative humidity in concrete slabs using in situ probes). Proceed with installation only after substrates have a maximum relative humidity measurement reading less than 80%. If relative humidity measurement reading is greater than or equal to 80%, Terroxy Moisture Vapor Treatment is required. Apply to terrazzo substrates according to Terroxy Resin Systems Moisture Vapor Treatment Product Data Sheet. An effective in situ probe for relative humidity testing is the RH BluePeg available from T&M Supply.
- .2 Prior to and during each day of installation, the terrazzo contractor shall verify that the dew point is at least 5°F (-15°C) less than the slab and air temperature.
- .3 Acceptable Substrates:
 - .1 Level tolerance: Concrete sub-floor shall be level with a maximum variation from level of 1/4" in 10 feet (6.4 mm in 3.1m). Any irregularity of the surface requiring patching and/or leveling shall be done using Terroxy Fill and selected aggregates as recommended by Terroxy Resin Systems.
 - .2 Concrete floor shall be prepared mechanically by shot blasting in accordance with ICRI Guideline No. 03732. Specifically, surface preparation results should achieve a CSP3-CSP5 profile.
 - .3 Concrete floor shall receive a steel trowel finish.
 - .4 Concrete shall be cured a minimum of 28 days. No curing agents are to be used in areas to receive terrazzo.
 - .5 Concrete slab on grade shall have an efficient moisture vapor barrier (suggested minimum: 15 mils (.4 mm thickness)) directly under the concrete slab. Reference ASTM Methods E1745 Class A and installed in accordance with E1643. Moisture barrier shall NOT be punctured.
 - .6 Saw cutting of control joints must be done between 12 and 24 hours after placement of the structural concrete and at a frequency compatible to ACI recommendations.
- .4 Provide permanent lighting or, if permanent lighting is not in place, simulate permanent lighting conditions during terrazzo installation.
- .5 Provide protection from other trades prior to final acceptance by owner.

Part 2 Products

2.1 MANUFACTURER'S

- .1 Work of this section shall be provided by one of the following manufacturer's
 - .1 Terroxy Resin Systems: Epoxy Terrazzo
 - .2 or approved alternative
- .2 All system components to be supplied by same manufacturer.

2.2 MATERIALS

- .1 Primer: Manufacturer's recommended moisture vapor treatment for slab on grade application
 - .1 Physical properties of moisture mitigating primer shall have a maximum of 0.3 perms with 100% RH.

- .2 Flexible Reinforcing Membrane: Manufacturer's recommended Epoxy Membrane, for substrate crack preparation and reflective crack reduction.
 - .1 Reinforcement: Fiberglass scrim
- .3 Epoxy Matrix: Epoxy Matrix and in color required for mix indicated.
 - .1 Physical properties without aggregates. All specimens cured for 7 days at 73-77°F (22.8-25°C) and 50 percent plus or minus 2 percent RH. This product shall meet the following requirements:
 - .1 Hardness to ASTM D-2240 using Shore-D Durometer: 60-85
 - .2 Tensile Strength to ASTM D-638: 3,000 psi min (20.7 MPA)
 - .3 Compressive Strength to ASTM D-695 Specimen B Cylinder 10,000 psi min (68.9 MPa)
 - .4 Chemical Resistance, ASTM D-1308 seven days at room temperature by immersion method with no Deleterious Effects:
 - .1 Distilled water
 - .2 Mineral Oil
 - .3 Isopropanol
 - .4 Ethanol
 - .5 0.025 Detergent Solution
 - .6 1% Soap Solution
 - .7 10% Sodium Hydroxide
 - .8 10% Hydrochloric Acid
 - .9 30% Sulfuric Acid
 - .10 5% Acetic Acid
 - .2 Physical properties with aggregates. For Epoxy Matrix blended with three volumes of Valdres marble blended 60% #1 chip and 40% #0 chip, ground and grouted with epoxy resin according to Installation Specifications, finishing to a nominal 3/8" (9.5 mm) thickness. All specimens cured for 7 days at 73-77°F (22.8-25°C) and 50 percent RH plus or minus 2 percent RH. This finished Epoxy Matrix shall meet the following requirements:
 - .1 Flammability to ASTM D-635: Self extinguishing, extend of burning to 0.25" max.
 - .2 Thermal Coefficient of Linear Expansion to ASTM D-696: 25x10⁻⁶ inches per inch per degree to 140 degrees F
 - .3 Bond Strength to ACI COMM 403, Bulletin 59-43: 300 psi (2.1 MPa - 100% concrete failure.
- .4 Aggregates: Marble complying with NTMA gradation standards for mix indicated and containing no deleterious or foreign matter.
 - .1 Abrasion and Impact Resistance: Less than 40 percent loss per ASTM C 131.
 - .2 24-Hour Absorption Rate: Less than 0.74 percent.
 - .3 Dust Content: Less than 1.0 percent by weight.
- .5 Finishing Grout: As recommended by Manufacturer.
- .6 Mix: Comply with NTMA's "Terrazzo Specifications and Design Guide" and manufacturer's written instructions for matrix and aggregate proportions and mixing.
 - .1 Mix Colours - Existing Areas:
 - .1 Field Colour: to match existing
 - .2 Chip Sizes - Existing Areas" Match existing

2.3 STRIP MATERIALS

- .1 Divider Strips: L-type
 - .1 16 gauge, Material White-zinc alloy selected from Domus Terrazzo full range

2.4 ACCESSORIES

- .1 Strip Adhesive: 100% solids epoxy resin adhesive recommended by Manufacturer.
 - .1 Use adhesive that has a VOC content of 50g/L or less when calculated according to 40 CFR 59, Subpart D (EPA Method 24).
- .2 Construction joints, contraction joints (Saw Cuts), isolation joints and cracks shall be detailed in accordance with NTMA technical bulletin T24
- .3 Patching and Fill Material: fill and selected aggregates as recommended by Manufacturer
- .4 Joint Compound: Manufacturer's recommended Joint Filler Hardener. Color to be selected by architect to match/compliment terrazzo flooring.
- .5 Cleaner: A neutral cleaner with pH factor between 7 & 10 specifically designed for terrazzo.
- .6 Surface Finish System: Level of polish to be specified by architect in accordance with desired appearance and level of reflectivity.
- .7 Sealer: Slip and stain-resistant sealer that is chemically neutral with a pH factor between 7 and 10, that meets a standard coefficient of friction of 0.5 or higher, as measured by the James Machine (ASTM D-2047 Test Method), does not affect physical properties of terrazzo and complies with NTMA's "Terrazzo Specifications and Design Guide."
 - .1 Acrylic Sealer, high performance, high gloss acrylic sealer.

2.5 PRECAST TERRAZZO

- .1 Precast Terrazzo Units: Precast epoxy terrazzo base units.
 - .1 All precast components to utilize same Terrazzo Manufactures products for fabrication to ensure color consistency with the poured in place flooring.
 - .2 Manufacturers: Subject to compliance with requirements, provided products acceptable to architect.
- .2 Precast Terrazzo Base Units: 1/2" thick, cast in maximum lengths possible, but not less than 48"
 - .1 Type: Precast Flat Type
 - .2 Height: 4"
 - .3 Outside Corner Units: With finished returned edges at outside corner.
 - .4 Color and Pattern: Match adjacent poured-in-place terrazzo flooring.
- .3 Terrazzo Cove Base: Precast Epoxy Terrazzo Cove Base, 4" high.

Part 3 Execution

3.1 EXAMINATION

- .1 Examine substrates and areas, with Terrazzo Contractor present, for compliance with requirements for installation tolerances and other conditions affecting performance.
- .2 Proceed with installation only after unsatisfactory conditions, including level tolerances, have been corrected.

3.2 PREPARATION

- .1 Clean substrates of substances, including oil, grease and curing compounds, that might impair terrazzo bond. Provide clean, dry and neutral substrate for terrazzo application.
- .2 Concrete Slabs:
 - .1 Provide sound concrete surface free of laitance, glaze, efflorescence, curing compounds, form- release agents, dust, dirt, grease, oil and other contaminants incompatible with terrazzo.

- .1 Prepare concrete mechanically by shot blasting. Surface preparation results should achieve a CSP3- CSP5 profile according to International Concrete Repair Institute Guideline No. 03732.
- .2 Repair or level damaged and deteriorated concrete according to manufacture's recommendations.
- .3 Repair cracks and non-expansion joints greater than 1/16" (1.6mm) wide according to NTMA Technical Bulletin T26 Crack Detailing and Joint Treatments.
- .2 Verify that concrete substrates are visibly dry and free of moisture.
- .3 Moisture Testing:
 - .1 Test for moisture according to ASTM F2170 (determining relative humidity in concrete slabs using in situ probes). An effective in situ probe for relative humidity testing is the Blue Peg available from Terrazzo & Marble Supply.
 - .2 Proceed with installation only after substrates have a maximum relative humidity measurement reading less than 80%. If relative humidity measurement reading is greater than or equal to 80%, Moisture Vapor Treatment is required. Apply to terrazzo substrates according to Product Data Sheet.
- .3 Protect other work from dust generated by grinding operations. Control dust to prevent air pollution and comply with environmental protection regulations.
 - .1 Erect and maintain temporary enclosures and other suitable methods to limit dust migration and to ensure adequate ambient temperatures and ventilation conditions during installation.

3.3 TERRAZZO INSTALLATION

- .1 General:
 - .1 Comply with NTMA's written recommendations for terrazzo and accessory installation.
 - .2 Place, rough grind, grout, cure grout, fine grind and finish terrazzo according to Manufacturer's recommendations and NTMA's "Terrazzo Specifications and Design Guide."
 - .3 Ensure that matrix components and fluids from grinding operations do not stain terrazzo by reacting with divider and control-joint strips.
 - .4 Delay fine grinding until heavy trade work is complete and construction traffic through area is restricted.
- .2 Thickness: 5/8"
- .3 Flexible Reinforcing Membrane
 - .1 Membrane application for isolated cracking. Route out all cracks and fill with 100% Manufacturer's Primer.
 - .2 Apply Manufacturer's Iso-Crack Epoxy Membrane (spread at 40 mils = 1.0 mm thickness) across the crack allowing 6" (152.4mm) on either side. Imbed fiberglass scrim at a minimum of 9" (22.8cm) into wet membrane and saturate with additional membrane.]
- .4 Primer: Apply to terrazzo substrates according to manufacturer's recommendations.
- .5 Strip Materials:
 - .1 Divider and Accessory Strips:
 - .1 Install strips in adhesive setting bed without voids below strips.
 - .2 Construction joints, contraction joints (Saw Cuts), isolation joints and cracks shall be detailed in accordance with NTMA technical bulletin T24.
- .6 Placing Terrazzo:
 - .1 Mix epoxy matrix with chips and fillers in ratios as per Manufacturer's written instructions

- .2 Trowel apply terrazzo mixture over epoxy primer to provide a dense flat surface to top of divider strips. Allow to cure per Manufacturer's recommendations before rough grinding.
- .7 Rough Grinding: Grind with 24 grit silicon carbide or 24 grit turbo diamonds until all terrazzo strips and marble chips are uniformly exposed.
- .8 Grouting:
 - .1 Cleanse floor with clean water and rinse.
 - .2 Remove excess rinse water by wet vacuum, dry and fill voids with Manufacturer's Epoxy Matrix or Clear Resin with a broadcast of filler.
 - .3 Allow grout to cure. Grout may be left on terrazzo until other trades work is completed.
- .9 Polishing: Polish with 120 grit T&M Resin Pads or equivalent stones until all grout is removed from surface. Produce surface with a minimum of 70 percent aggregate exposure.

3.4 PRECAST TERRAZZO INSTALLATION

- .1 Install precast units using method recommended by NTMA and manufacturer unless otherwise indicated.
- .2 Seal joints between units with joint sealants.

3.5 CLEANING AND PROTECTION

- .1 Cleaning: Remove grinding dust from installation and wash all surfaces with a neutral cleaner with a pH factor between 7-10. .
- .2 Sealing: Apply TRx sealer that is chemically neutral with a pH factor between 7 and 10, that meets a standard coefficient of friction of 0.5 or higher, as measured by the James Machine (ASTM D-2047 Test Method), does not affect physical properties of terrazzo and complies with NTMA's
- .3 Protection: Upon completion, the work shall be ready for final inspection and acceptance by the owner or his agent. Provide final protection and maintain conditions, in a manner acceptable to terrazzo contractor, that ensure terrazzo is without damage or deterioration.

END OF SECTION

Part 1 General

1.1 SUMMARY

- .1 Section Includes:
 - .1 Material and installation of site applied paint finishes to new interior surfaces, including site painting of shop primed surfaces.

1.2 REFERENCES

- .1 Department of Justice Canada (Jus)
 - .1 Canadian Environmental Protection Act (CEPA), 1999, c. 33
 - .2 Environmental Protection Agency (EPA)
 - .1 EPA Test Method for Measuring Total Volatile Organic Compound Content of Consumer Products, Method 24 - 1995, (for Surface Coatings).
 - .3 Health Canada / Workplace Hazardous Materials Information System (WHMIS)
 - .1 Material Safety Data Sheets (MSDS).
 - .4 Master Painters Institute (MPI)
 - .1 MPI Architectural Painting Specifications Manual, 2004.
 - .5 National Fire Code of Canada - 1995
 - .6 Society for Protective Coatings (SSPC)
 - .1 SSPC Painting Manual, Volume Two, 8th Edition, Systems and Specifications Manual.
 - .7 Transport Canada (TC)
 - .1 Transportation of Dangerous Goods Act (TDGA), 1992, c. 34.

1.3 QUALITY ASSURANCE

- .1 Qualifications:
 - .1 Contractor: minimum of five years proven satisfactory experience. Provide list of last three comparable jobs including, job name and location, specifying authority, and project manager.
 - .2 Journeymen: qualified journeymen who have "Tradesman Qualification Certificate of Proficiency" engaged in painting work.
 - .3 Apprentices: working under direct supervision of qualified trades person in accordance with trade regulations.
- .2 Health and Safety:
 - .1 Do construction occupational health and safety in accordance with Section 01 35 29 - Health and Safety Requirements.

1.4 ACTION AND INFORMATIONAL SUBMITTALS

- .1 Submittals in accordance with Section 01 33 00 - Submittal Procedures.
- .2 Product Data:
 - .1 Submit product data and instructions for each paint and coating product to be used.

- .2 Submit product data for the use and application of paint thinner.
- .3 Submit two copies of Workplace Hazardous Materials Information System (WHMIS) Material Safety Data Sheets (MSDS).
- .3 Samples:
 - .1 Submit full range colour sample chips to indicate where colour availability is restricted.
 - .2 Submit 200 x 300 mm sample panels of each paint, stain or clear coating with specified paint or coating in colours, gloss/sheen and textures required to MPI Architectural Painting Specification Manual standards.
 - .3 Retain reviewed samples on-site to demonstrate acceptable standard of quality for appropriate on-site surface.
 - .4 Certificates: submit certificates signed by manufacturer certifying that materials comply with specified performance characteristics and physical properties.
 - .5 Manufacturer's Instructions:
 - .1 Submit manufacturer's installation and application instructions.
 - .6 Closeout Submittals: submit maintenance data for incorporation into manual specified in Section 01 77 00 - Closeout Submittals include following:
 - .1 Product name, type and use.
 - .2 Manufacturer's product number.
 - .3 Colour numbers.
 - .4 MPI Environmentally Friendly classification system rating.

1.5 DELIVERY, STORAGE AND HANDLING

- .1 Packing, Shipping, Handling and Unloading:
 - .1 Pack, ship, handle and unload materials in accordance with Section 01 61 00 - Common Product Requirements and manufacturer's written instructions.
 - .2 Acceptance at Site:
 - .1 Identify products and materials with labels indicating:
 - .1 Manufacturer's name and address.
 - .2 Type of paint or coating.
 - .3 Compliance with applicable standard.
 - .4 Colour number in accordance with established colour schedule.
 - .3 Remove damaged, opened and rejected materials from site.
 - .4 Storage and Protection:
 - .1 Provide and maintain dry, temperature controlled, secure storage.
 - .2 Store materials and supplies away from heat generating devices.
 - .3 Store materials and equipment in well ventilated area with temperature range 7 degrees C to 30 degrees C.
 - .5 Store temperature sensitive products above minimum temperature as recommended by manufacturer.
 - .6 Keep areas used for storage, cleaning and preparation clean and orderly. After completion of operations, return areas to clean condition.
 - .7 Remove paint materials from storage only in quantities required for same day use.
 - .8 Fire Safety Requirements:
 - .1 Provide one Type ABC fire extinguisher adjacent to storage area.
 - .2 Store oily rags, waste products, empty containers and materials subject to spontaneous combustion in ULC approved, sealed containers and remove from site on a daily basis.

- .3 Handle, store, use and dispose of flammable and combustible materials in accordance with National Fire Code of Canada requirements.
- .4 Where paint recycling is available, collect waste paint by type and provide for delivery to recycling or collection facility.

1.6 SITE CONDITIONS

- .1 Heating, Ventilation and Lighting:
 - .1 Ventilate enclosed spaces in accordance with Section 01 51 00 .
 - .2 Provide heating facilities to maintain ambient air and substrate temperatures above 10 degrees C for 24 hours before, during and after paint application until paint has cured sufficiently.
 - .3 Provide continuous ventilation for seven days after completion of application of paint.
 - .4 Provide temporary ventilating and heating equipment where permanent facilities are not available or supplemental ventilating and heating equipment if ventilation and heating from existing system is inadequate to meet minimum requirements.
 - .5 Provide minimum lighting level of 323 Lux on surfaces to be painted.
- .2 Temperature, Humidity and Substrate Moisture Content Levels:
 - .1 Perform no painting when:
 - .1 Ambient air and substrate temperatures are below 10 degrees C.
 - .2 Substrate temperature is above 32 degrees C unless paint is specifically formulated for application at high temperatures.
 - .3 Substrate and ambient air temperatures are not expected to fall within MPI or paint manufacturer's prescribed limits.
 - .4 The relative humidity is under 85% or when the dew point is more than 3 degrees C variance between the air/surface temperature. Paint should not be applied if the dew point is less than 3 degrees C below the ambient or surface temperature. Use sling psychrometer to establish the relative humidity before beginning paint work.
 - .5 Rain or snow are forecast to occur before paint has thoroughly cured or when it is foggy, misty, raining or snowing at site.
 - .6 Ensure that conditions are within specified limits during drying or curing process, until newly applied coating can itself withstand 'normal' adverse environmental factors.
 - .2 Perform painting work when maximum moisture content of the substrate is below:
 - .1 Allow new concrete and masonry to cure minimum of 28 days.
 - .2 15% for wood.
 - .3 12% for plaster and gypsum board.
 - .3 Test for moisture using calibrated electronic Moisture Meter.
 - .4 Test concrete, masonry and plaster surfaces for alkalinity as required.
 - .5 Surface and Environmental Conditions:
 - .1 Apply paint finish in areas where dust is no longer being generated by related construction operations or when wind or ventilation conditions are such that airborne particles will not affect quality of finished surface.
 - .2 Apply paint to adequately prepared surfaces and to surfaces within moisture limits.
 - .3 Apply paint when previous coat of paint is dry or adequately cured.
 - .3 Additional interior application requirements:
Apply paint finishes when temperature at location of installation can be satisfactorily maintained within manufacturer's recommendations.

Part 2
2.1

Products
MATERIALS

- .1 Paint materials listed in the MPI Approved Products List (APL) are acceptable for use on this project.
- .2 Provide paint materials for paint systems from single manufacturer.
- .3 Conform to latest MPI requirements for interior painting work including preparation and priming.
- .4 Materials (primers, paints, coatings, varnishes, stains, lacquers, fillers, thinners, solvents, etc.) in accordance with MPI Architectural Painting Specification Manual "Approved Product" listing.
- .5 Linseed oil, shellac, and turpentine: highest quality product from approved manufacturer listed in MPI Architectural Painting Specification Manual, compatible with other coating materials as required.
- .6 Paints, coatings, adhesives, solvents, cleaners, lubricants, and other fluids:
 - .1 Water-based.
 - .2 non-flammable.
 - .3 Manufactured without compounds which contribute to ozone depletion in the upper atmosphere.
 - .4 Manufactured without compounds which contribute to smog in the lower atmosphere.
 - .5 Do not contain methylene chloride, chlorinated hydrocarbons, toxic metal pigments.
 - .7 Formulate and manufacture water-borne surface coatings with no aromatic solvents, formaldehyde, halogenated solvents, mercury, lead, cadmium, hexavalent chromium or their compounds.
 - .8 Flash point: 61.0 degrees C or greater for water-borne surface coatings and recycled water-borne surface coatings.
 - .9 Ensure manufacture and process of both water-borne surface coatings and recycled water-borne surface coatings does not release:
 - .1 Matter in undiluted production plant effluent generating 'Biochemical Oxygen Demand' (BOD) in excess of [15] mg/L to natural watercourse or sewage treatment facility lacking secondary treatment.
 - .2 Total Suspended Solids (TSS) in undiluted production plant effluent in excess of [15] mg/L to natural watercourse or a sewage treatment facility lacking secondary treatment.

2.2

COLOURS

- .1 Consultant will provide Colour Schedule after award of contract.
- .2 Colour schedule will be based upon selection of Two (2) base colours and two (2) accent colours.
- .3 Selection of colours from manufacturers full range of colours.
- .4 Where specific products are available in restricted range of colours, selection based on limited range.
- .5 Second coat in three coat system to be tinted slightly lighter colour than top coat to show visible difference between coats.

2.3

MIXING AND TINTING

- .1 Perform colour tinting operations prior to delivery of paint to site.
- .2 Mix paste, powder or catalyzed paint mixes in accordance with manufacturer's written instructions.

- .3 Use and add thinner in accordance with paint manufacturer's recommendations. Do not use kerosene or similar organic solvents to thin water-based paints.
- .4 Thin paint for spraying in accordance with paint manufacturer's instructions.
- .5 Re-mix paint in containers prior to and during application to ensure break-up of lumps, complete dispersion of settled pigment, and colour and gloss uniformity.

2.4 GLOSS/SHEEN RATINGS

- .1 Paint gloss is defined as sheen rating of applied paint, in accordance with following values:

	Gloss @ 60 degrees	Sheen @ 85 degrees
Gloss Level 1 - Matte Finish (flat)	Max. 5	Max. 10
Gloss Level 2 - Velvet-Like Finish	Max.10	10 to 35
Gloss Level 3 - Eggshell Finish	10 to 25	10 to 35
Gloss Level 4 - Satin-Like Finish	20 to 35	min. 35
Gloss Level 5 - Traditional Semi-Gloss Finish	35 to 70	
Gloss Level 6 - Traditional Gloss	70 to 85	
Gloss Level 7 - High Gloss Finish	More than 85	

2.5 INTERIOR PAINTING SYSTEMS

- .1 Acceptable Products:
 - .1 PPG Pitt-Glaze WB1 pre-catalyzed water-borne acrylic epoxy
 - .2 Corotech High Performance pre-catalyzed water-borne acrylic epoxy
 - .3 or approved alternate
- .2 Concrete masonry units: smooth and split face block and brick:
 - .1 Semi Gloss level 5
- .3 Galvanized metal: doors, frames, railings, misc. steel, pipes and ducts.
 - .1 Semi Gloss level 5
- .4 For Gypsum Wall Board: Eggshell Gloss Level 3
- .5 For woodwork to receive stained finish apply
 - .1 One coat wood filler
 - .2 Two coats solvent based stain CAN/CGSB-1.145. Type 2 (interior) Class B semi Transparent.
 - .3 One coat oil modified clear polyurethane CAN/CGSB-1.175 Type 1 gloss
 - .4 Two coat oil modified clear polyurethane CAN/CGSB-1.175 Type 2 satin
- .6 For woodwork to receive clear finish apply:
 - .1 One coat wood filler
 - .2 One coat oil modified clear polyurethane CAN/CGSB-1.175 Type 1 gloss
 - .3 Two coat oil modified clear polyurethane CAN/CGSB-1.175 Type 2 satin

2.6 EXTERIOR PAINTING SYSTEMS

- .1 Concrete Masonry Units: smooth and split face block and brick
 - .1 EXT 4.2A - Latex Gloss Level 3 finish.

- .2 Structural Steel and Metal Fabrications:
 - .1 EXT 5.1A - Quick dry enamel Gloss Level 3 finish.
- .3 Galvanized Metal: not chromate passivated
 - .1 EXT 5.3A - Latex Gloss Level 5 finish.
- .4 Dimension Lumber: columns, beams, exposed joists, underside of decking, siding, fencing, etc.
 - .1 EXT 6.2A - Latex Gloss Level 5 finish (over alkyd primer).
- .5 Dressed Lumber: doors, door and window frames, casings, battens, smooth facias, etc.
 - .1 EXT 6.3A - Latex Gloss Level 5 finish.

Part 3
3.1

Execution
MANUFACTURER'S INSTRUCTIONS

- .1 Compliance: comply with manufacturer's written recommendations or specifications, including product technical bulletins, handling, storage and installation instructions, and data sheet.

3.2

GENERAL

- .1 Perform preparation and operations for interior painting in accordance with MPI Architectural Painting Specifications Manual except where specified otherwise.
- .2 Apply paint materials in accordance with paint manufacturer's written application instructions.

3.3

EXAMINATION

- .1 Investigate existing substrates for problems related to proper and complete preparation of surfaces to be painted. Report to Consultant damages, defects, unsatisfactory or unfavourable conditions before proceeding with work.
- .2 Conduct moisture testing of surfaces to be painted using properly calibrated electronic moisture meter, except test concrete floors for moisture using simple "cover patch test". Do not proceed with work until conditions fall within acceptable range as recommended by manufacturer.
- .3 Maximum moisture content as follows:
 - .1 Stucco, plaster and gypsum board: 12%.
 - .2 Concrete: 12%.
 - .3 Clay and Concrete Block/Brick: 12%.
 - .4 Wood: 15%.

3.4

PREPARATION

- .1 Protection:
 - .1 Protect existing building surfaces and adjacent structures from paint spatters, markings and other damage by suitable non-staining covers or masking. If damaged, clean and restore surfaces as directed by [Departmental Representative] [DCC Representative] [Consultant].
 - .2 Protect items that are permanently attached such as Fire Labels on doors and frames.
 - .3 Protect factory finished products and equipment.

- .4 Protect [passing pedestrians], [building occupants] [and general public] in and about the building.
- .2 Surface Preparation:
 - .1 Remove electrical cover plates, light fixtures, surface hardware on doors, bath accessories and other surface mounted equipment, fittings and fastenings prior to undertaking painting operations. Identify and store items in secure location and re-installed after painting is completed.
 - .2 Move and cover furniture and portable equipment as necessary to carry out painting operations. Replace as painting operations progress.
 - .3 Place "WET PAINT" signs in occupied areas as painting operations progress.
- .3 Clean and prepare surfaces in accordance with MPI Architectural Painting Specification Manual requirements. Refer to MPI Manual in regard to specific requirements and as follows:
 - .1 Remove dust, dirt, and other surface debris by wiping with dry, clean cloths.
 - .2 Wash surfaces with a biodegradable detergent [and bleach where applicable] and clean warm water using a stiff bristle brush to remove dirt, oil and other surface contaminants.
 - .3 Rinse scrubbed surfaces with clean water until foreign matter is flushed from surface.
 - .4 Allow surfaces to drain completely and allow to dry thoroughly.
 - .5 Prepare surfaces for water-based painting, water-based cleaners should be used in place of organic solvents.
 - .6 Use trigger operated spray nozzles for water hoses.
 - .7 Many water-based paints cannot be removed with water once dried. Minimize use of mineral spirits or organic solvents to clean up water-based paints.
- .4 Prevent contamination of cleaned surfaces by salts, acids, alkalis, other corrosive chemicals, grease, oil and solvents before prime coat is applied and between applications of remaining coats. Apply primer, paint, or pretreatment as soon as possible after cleaning and before deterioration occurs.
- .5 Where possible, prime non-exposed surfaces of new wood surfaces before installation. Use same primers as specified for exposed surfaces.
 - .1 Apply vinyl sealer to MPI #36 over knots, pitch, sap and resinous areas.
 - .2 Apply wood filler to nail holes and cracks.
 - .3 Tint filler to match stains for stained woodwork.
- .6 Sand and dust between coats as required to provide adequate adhesion for next coat and to remove defects visible from a distance up to 1000 mm.
- .7 Clean metal surfaces to be painted by removing rust, loose mill scale, welding slag, dirt, oil, grease and other foreign substances in accordance with MPI requirements. Remove traces of blast products from surfaces, pockets and corners to be painted by brushing with clean brushes.
- .8 Touch up of shop primers with primer as specified.
- .9 Do not apply paint until prepared surfaces have been accepted by Consultant,

3.5 APPLICATION

- .1 Method of application to be as approved by Consultant. Apply paint by brush, roller or sprayer. Conform to manufacturer's application instructions unless specified otherwise.

- .2 Brush and Roller Application:
 - .1 Apply paint in uniform layer using brush and/or roller type suitable for application.
 - .2 Work paint into cracks, crevices and corners.
 - .3 Paint surfaces and corners not accessible to brush using spray, daubers and/or sheepskins. Paint surfaces and corners not accessible to roller using brush, daubers or sheepskins.
 - .4 Brush and/or roll out runs and sags, and over-lap marks. Rolled surfaces free of roller tracking and heavy stipple.
 - .5 Remove runs, sags and brush marks from finished work and repaint.
- .3 Spray application:
 - .1 Provide and maintain equipment that is suitable for intended purpose, capable of atomizing paint to be applied, and equipped with suitable pressure regulators and gauges.
 - .2 Keep paint ingredients properly mixed in containers during paint application either by continuous mechanical agitation or by intermittent agitation as frequently as necessary.
 - .3 Apply paint in uniform layer, with overlapping at edges of spray pattern. Back roll first coat application.
 - .4 Brush out immediately all runs and sags.
 - .5 Use brushes and rollers to work paint into cracks, crevices and places which are not adequately painted by spray.
- .4 Use dipping, sheepskins or daubers only when no other method is practical in places of difficult access.
- .5 Apply coats of paint continuous film of uniform thickness. Repaint thin spots or bare areas before next coat of paint is applied.
- .6 Allow surfaces to dry and properly cure after cleaning and between subsequent coats for minimum time period as recommended by manufacturer.
- .7 Sand and dust between coats to remove visible defects.
- .8 Finish surfaces both above and below sight lines as specified for surrounding surfaces, including such surfaces as tops of interior cupboards and cabinets and projecting ledges.
- .9 Finish inside of cupboards and cabinets as specified for outside surfaces.
- .10 Finish closets and alcoves as specified for adjoining rooms.
- .11 Finish top, bottom, edges and cut-outs of doors after fitting as specified for door surfaces.

3.6 MECHANICAL ELECTRICAL EQUIPMENT

- .1 Paint finished area exposed conduits, piping, hangers, ductwork and other mechanical and electrical equipment with colour and finish to match adjacent surfaces, except as indicated.
- .2 Boiler room, mechanical and electrical rooms: paint exposed conduits, piping, hangers, ductwork and other mechanical and electrical equipment.
- .3 Other unfinished areas: leave exposed conduits, piping, hangers, ductwork and other mechanical and electrical equipment in original finish and touch up scratches and marks.
- .4 Touch up scratches and marks on factory painted finishes and equipment with paint as supplied by manufacturer of equipment.

- .5 Do not paint over nameplates.
- .6 Keep sprinkler heads free of paint.
- .7 Paint inside of ductwork where visible behind grilles, registers and diffusers with primer and one coat of matt black paint.
- .8 Paint exposed fire protection piping to match ceiling.
- .9 Paint disconnect switches for fire alarm system and exit light systems in red enamel.
- .10 Paint natural gas piping yellow.
- .11 Paint both sides and edges of backboards for telephone and electrical equipment before installation. Leave equipment in original finish except for touch-up as required, and paint conduits, mounting accessories and other unfinished items.
- .12 Do not paint interior transformers and substation equipment.

3.7 SITE TOLERANCES

- .1 Walls: no defects visible from a distance of 1000 mm at 90 degrees to surface.
- .2 Ceilings: no defects visible from floor at 45 degrees to surface when viewed using final lighting source.
- .3 Final coat to exhibit uniformity of colour and uniformity of sheen across full surface area.

3.8 FIELD QUALITY CONTROL

- .1 Interior painting and decorating work shall be inspected by a Paint Inspection Agency (inspector) acceptable to the specifying authority and local Painting Contractor's Association. Painting contractor shall notify Paint Inspection Agency a minimum of one week prior to commencement of work and provide a copy of project painting specification, plans and elevation drawings (including pertinent details) as well as a Finish Schedule.
- .2 Interior surfaces requiring painting shall be inspected by Paint Inspection Agency who shall notify Consultant and General Contractor in writing of defects or problems, prior to commencing painting work, or after prime coat shows defects in substrate.
- .3 Standard of Acceptance:
 - .1 Walls: no defects visible from a distance of 1000 mm at 90 degrees to surface.
 - .2 Ceilings: no defects visible from floor at 45 degrees degrees to surface when viewed using final lighting source.
 - .3 Final coat to exhibit uniformity of colour and uniformity of sheen across full surface area.
- .4 Advise Consultant when surfaces and applied coating is ready for inspection. Do not proceed with subsequent coats until previous coat has been approved.
- .5 Cooperate with inspection firm and provide access to areas of work.

3.9 RESTORATION

- .1 Clean and re-install hardware items removed before undertaken painting operations.
- .2 Remove protective coverings and warning signs as soon as practical after operations cease.
- .3 Remove paint splashing on exposed surfaces that were not painted. Remove smears and spatter immediately as operations progress, using compatible solvent.

- .4 Protect freshly completed surfaces from paint droppings and dust to approval of Consultant. Avoid scuffing newly applied paint.
- .5 Restore areas used for storage, cleaning, mixing and handling of paint to clean condition as approved by Consultant.

END OF SECTION

Part 1 General

1.1 RELATED SECTIONS

- .1 Rough Carpentry: Section 06 10 00.

1.2 REFERENCES

- .1 CAN/CGSB-12.5-M86, Mirrors, Silvered.
- .6 CAN/CSA-B651-07(r012), Barrier-Free Design.

1.3 SUBMITTALS

- .1 Submit shop drawings in accordance with section 01 33 00.
- .2 Indicate size and description of components, base material, surface finish inside and out, hardware and locks, attachment devices, description of rough-in-frame, building-in details of anchors for grab bars.

1.4 SUBMITTALS

- .1 Provide maintenance data for toilet and bath accessories for incorporation into manual specified in Section 01 77 00 – Closeout Procedures & Submittals

1.5 EXTRA MATERIALS

- .1 Provide special tools required for accessing, assembly/disassembly or removal for toilet and bath accessories in accordance with requirements specified in Section 01 77 00.

Part 2 Products

2.1 MATERIALS

- .1 Sheet steel: commercial quality to ASTM A526M with ZF001 designation zinc coating.
- .2 Stainless steel sheet metal: to ASTM A167, Type 304 with BA finish.
- .3 Stainless steel tubing: Type 304, commercial grade, seamless welded, 1.2 mm wall thickness.
- .4 Fasteners: concealed screws and bolts hot dip galvanized, exposed fasteners to match face of unit. Expansion shields fibre, lead or rubber as recommended by accessory manufacturer for component and its intended use.

2.2 ACCESSORIES

- .1 Refer to drawings for accessories schedule.
- .2 Install all washroom accessories that are supplied by owner, as indicated on the drawings
- .3 Accessory schedule is based on Frost Products Limited. ASI Watrous, Bobrick Washroom Equipment and Bradley Corp accessories are approved alternates.

2.3 FABRICATION

- .1 Weld and grind joints of fabricated components flush and smooth. Use mechanical fasteners only where approved.
- .2 Wherever possible form exposed surfaces from one sheet of stock, free of joints.
- .3 Brake form sheet metal work with 1.5 mm radius bends.
- .4 Form surfaces flat without distortion. Maintain flat surfaces without scratches or dents.
- .5 Back paint components where contact is made with building finishes to prevent electrolysis.
- .6 Hot dip galvanize concealed ferrous metal anchors and fastening devices to CSA G164.
- .7 Shop assemble components and package complete with anchors and fittings.
- .8 Deliver inserts and rough-in frames to job site at appropriate time for building-in. Provide templates, details and instructions for building in anchors and inserts.
- .9 Provide steel anchor plates and components for installation on studding and building framing.

2.4 FINISHES

- .1 Chrome and nickel plating: to ASTM B456, satin or polished finish.

Part 3 Execution

3.1 INSTALLATION

- .1 Install and secure accessories rigidly in place as follows:
 - .1 Stud walls: install steel back-plate to stud prior to plaster or drywall finish. Provide plate with threaded studs or plugs.
 - .2 Hollow masonry units or existing plaster/drywall: use toggle bolts drilled into cell/wall cavity.
 - .3 Toilet/shower compartments: use male/female through bolts.
- .2 Install grab bars on built-in anchors provided by bar manufacturer.
- .3 Use tamper proof screws/bolts for fasteners.
- .4 Install mirrors in accordance with manufacturer's instructions and CSA B651.

3.2 SCHEDULE

- .1 Locate accessories where indicated. Exact locations determined by Consultant.
- .2 Refer to Washroom Accessory Schedule located on drawings.

3.3 ADJUSTING

- .1 Adjust toilet and bathroom accessories components and systems for correct function and operation in accordance with manufacturer's written instructions.
- .2 Lubricate moving parts to operate smoothly and fit accurately.

3.4 CLEANING

- .1 Progress Cleaning: clean in accordance with Section 01 74 11 - Cleaning.
- .2 Leave Work area clean at end of each day.
- .3 Final Cleaning: upon completion remove surplus materials, rubbish, tools and equipment in accordance with Section 01 74 11 - Cleaning.
- .4 Waste Management: separate waste materials for reuse or recycling.
- .5 Remove recycling containers and bins from site and dispose of materials at appropriate facility.

End Of Section

TYPICAL MOUNTING HEIGHTS

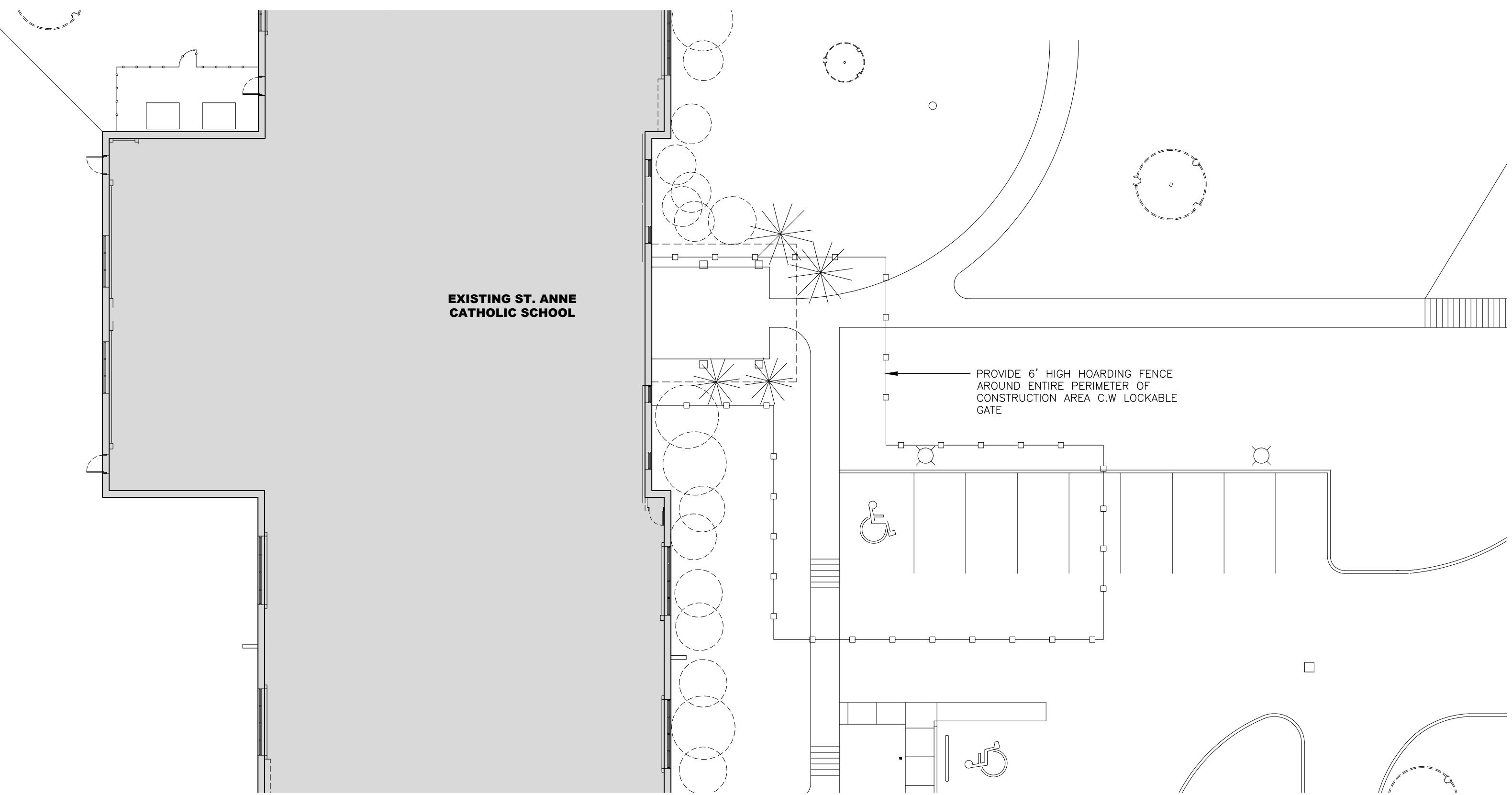
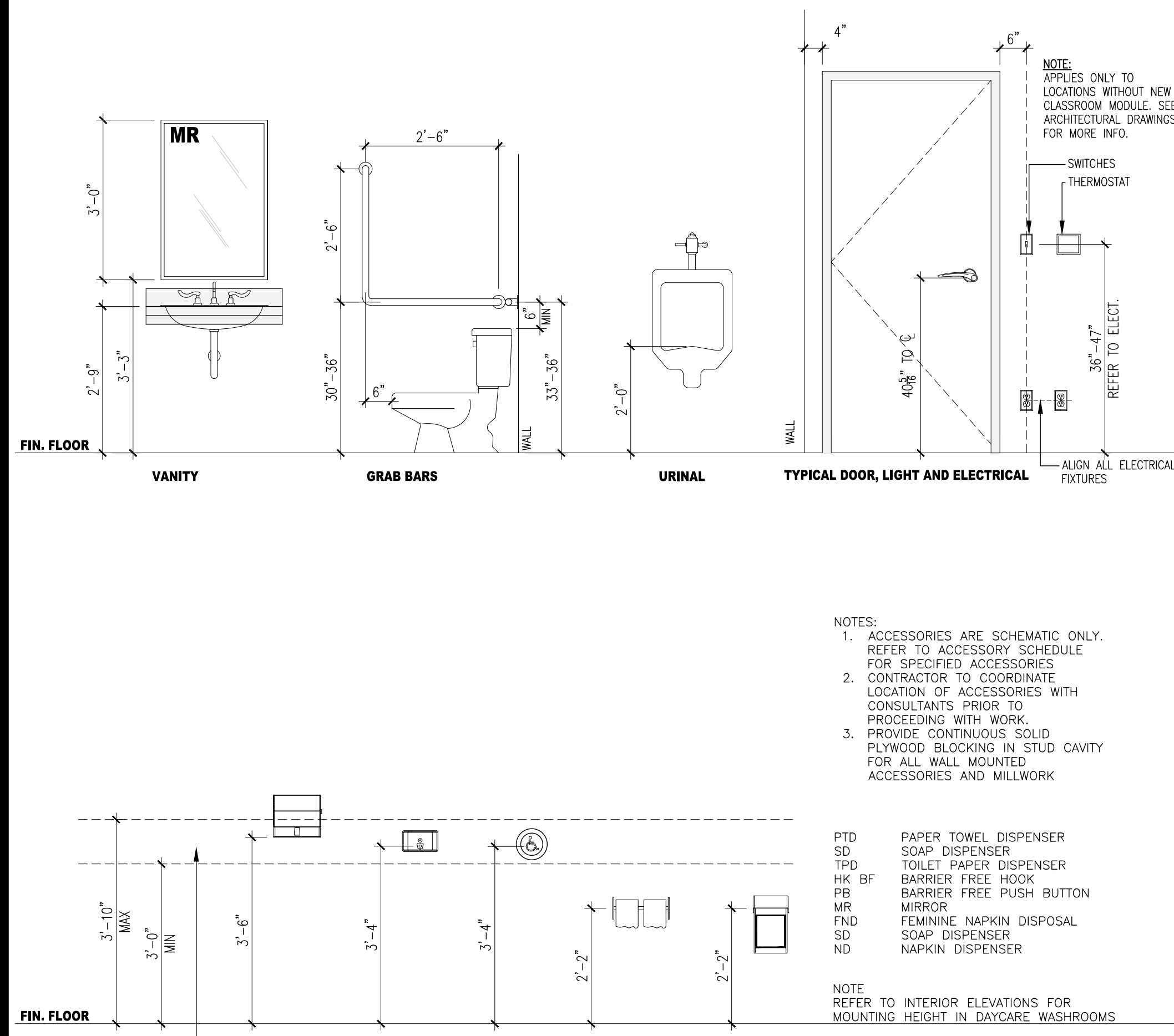

01 SITE HOARDING PLAN

ASSEMBLY TYPES SCHEDULE

PARTITION TYPES

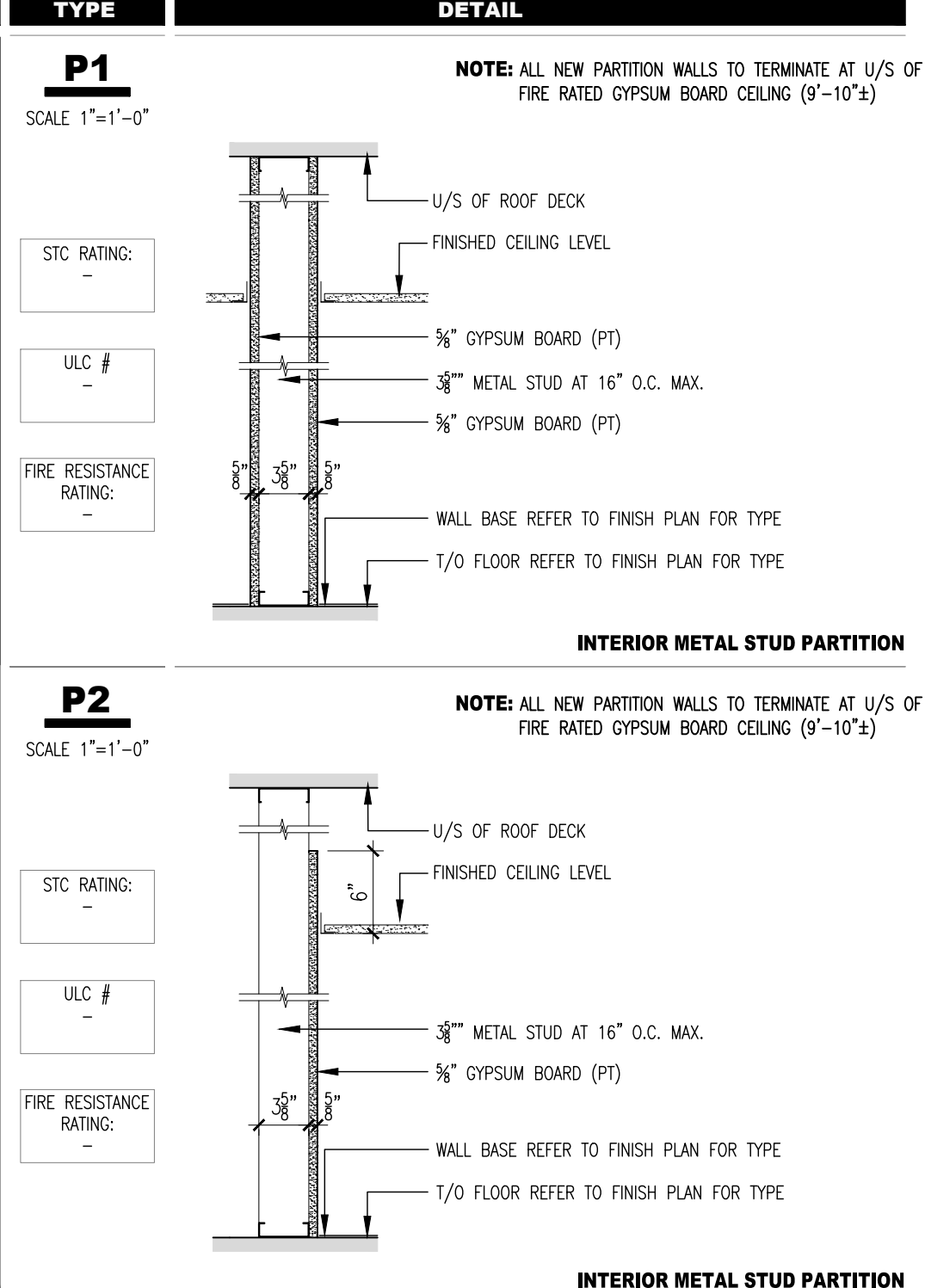

ONTARIO BUILDING CODE MATRIX

PART 11		OBC REFERENCE	
1	EXISTING BUILDING CLASSIFICATION:	DESCRIBE EXISTING USE: GROUP A2 CONSTRUCTION INDEX: HAZARD INDEX:	11.2.1 11.2.1.1A 11.2.1.1B to N
2	ALTERATION TO EXISTING BUILDING IS:	BASIC RENOVATION: <input checked="" type="checkbox"/> EXTENSIVE RENOVATION: <input type="checkbox"/>	11.3.3.1 11.3.3.2
3	REDUCTION IN PERFORMANCE LEVEL:	STRUCTURAL: BY INCREASE IN OCCUPANT LOAD: BY CHANGE OF MAJOR OCCUPANCY: PLUMBING: SEWAGE-SYSTEM:	11.4.2, 11.4.2.1 11.4.2.2 11.4.2.3 11.4.2.4 11.4.2.5
4	COMPENSATING CONSTRUCTION:	STRUCTURAL: INCREASE IN OCCUPANT LOAD: CHANGE OF MAJOR OCCUPANCY: PLUMBING: SEWAGE SYSTEM:	11.4.3 11.4.3.2 11.4.3.3 11.4.3.4 11.4.3.5 11.4.3.6
5	COMPLIANCE ALTERNATIVES PROPOSED:	<input checked="" type="checkbox"/> NO <input type="checkbox"/> YES (GIVE NUMBER(S))	11.5.1

2012 BUILDING CODE DATA MATRIX, PART 11
© 2014 ONTARIO ASSOCIATION OF ARCHITECTS

SITE KEY PLAN



BUILDING KEY PLAN

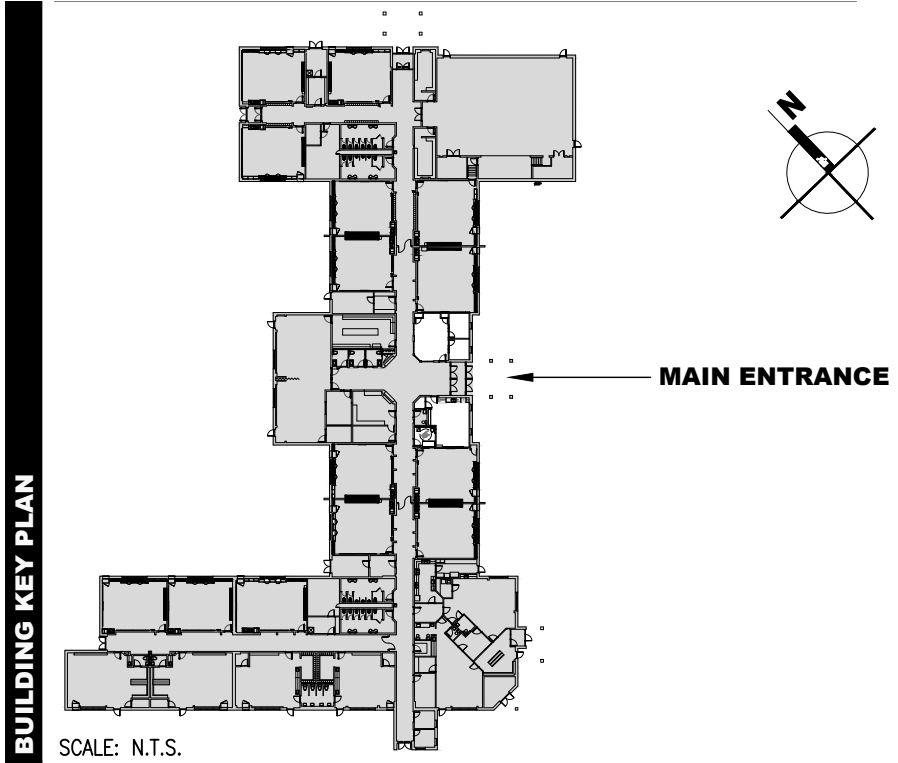

HOARDING SCHEDULE

H1

CONSTRUCTION HOARDING TYPE 1:
6' HIGH CONTINUOUS CONSTRUCTION FENCE C/W 6mil POLY BARRIER FROM FLOOR TO CEILING. SEAL POLY BARRIER TO FLOOR AND CEILING TO PREVENT DUST MIGRATION.

NOTE: POLY BARRIER TO BE ERECTED PRIOR TO DEMOLITION AND REMOVED ONCE ALL WORK AREAS HAVE BEEN CLEANED AFTER CONSTRUCTION AND SPACE IS READY FOR CLIENT TAKE OVER.

GENERAL NOTES

No.	NOTES	No.	NOTES
1.	DO NOT SCALE THE DRAWINGS	11.	GENERAL CONTRACTOR TO PROVIDE OWN TEMPORARY FACILITIES (WASHROOM, DUMPSTER, CONSTRUCTION TRAILER ETC.)
2.	WORK SHALL BE PERFORMED IN A MANNER THAT WILL MINIMIZE THE INTERRUPTION OF ACCESS IN ALL AREAS AFFECTED BY CONSTRUCTION.	12.	ALL NOISY, DUSTY AND ABATEMENT WORK TO BE PERFORMED AFTER REGULAR SCHOOL HOURS. CO-ORDINATE WITH OWNER.
3.	ALL MATERIAL AND WORKMANSHIP SHALL COMPLY WITH ALL APPLICABLE CANADIAN CONSTRUCTION STANDARDS AND THE ONTARIO BUILDING CODE (2012).	13.	LOCATE ACCESS PANELS AS INDICATED ON DRAWINGS. FOR ACCESS PANELS NOT SHOWN BUT REQ'D BY PROVISIONS OF THE CONTRACT DOCUMENTS, LOCATED IN ACCORDANCE WITH APPLICABLE CODES. SUBMIT PROPOSED LOCATIONS TO THE ARCHITECT FOR REVIEW AND ACCEPTANCE PRIOR TO INSTALLATION.
4.	REFER TO COMPLETE SET OF ISSUED CONTRACT DOCUMENTS FOR OTHER APPLICABLE NOTES, ABBREVIATIONS AND SYMBOLS.	14.	ALL OMISSIONS OR CONFLICTS BETWEEN THE VARIOUS ELEMENTS OF THE CONTRACT DRAWINGS AND I/O SPECIFICATIONS SHALL BE BROUGHT TO THE ATTENTION OF THE CONSULTANTS BEFORE PROCEEDING WITH ANY WORK INVOLVED.
5.	DRAWINGS ARE TO BE READ IN CONJUNCTION WITH THE MECHANICAL, PLUMBING, ELECTRICAL.	15.	THE CONTRACTOR SHALL BE RESPONSIBLE FOR THE PROTECTION OF AND THE SAFETY IN AND AROUND THE CONSTRUCTION AREA.
6.	FIELD MEASURE AND CONFIRM DIMENSIONS FOR OWNER PROVIDED EQUIPMENT AND FURNISHINGS.	16.	COMPLIANCE WITH CODES AND ORDINANCES GOVERNING THE WORK SHALL BE MADE AND ENFORCED BY THE GENERAL CONTRACTOR.
7.	THE CONTRACTOR SHALL VERIFY ALL DIMENSIONS AND EXISTING CONDITIONS ON SITE AND SHALL REPORT ALL DISCREPANCIES TO THE CONSULTANT BEFORE PROCEEDING WITH THE WORK.	17.	MANUFACTURER'S SPECIFICATIONS FOR INSTALLATION OF MATERIALS SHALL BE FOLLOWED.
8.	WORKMANSHIP THROUGHOUT SHALL BE OF THE BEST QUALITY OF THE TRADE INVOLVED AND THE GENERAL CONTRACTOR SHALL COORDINATE THE WORK OF THE VARIOUS TRADES TO EXPEDITE THE JOB IN A SMOOTH AND CONTINUOUS PROCESS.	18.	BUILDING WILL BE OCCUPIED DURING REGULAR SCHOOL HOURS. MAINTAIN HEATING CONTROL IN OCCUPIED BUILDING, EXCEPT CONSTRUCTION AREAS, AT ALL TIMES. MAINTAIN A MINIMUM HEAT LEVEL IN WORK AREAS TO PROTECT EXISTING FINISHES / EQUIPMENT.
9.	WHERE MATERIALS ARE APPLIED TO, OR ARE IN DIRECT CONTACT WITH WORK INSTALLED BY ANOTHER SUBCONTRACTOR, COMMENCEMENT OF WORK IMPLIES ACCEPTANCE OF THE SUBSTRATE AS SUITABLE FOR THE APPLICATION INTENDED.		
10.	NOTES APPEAR ON VARIOUS DRAWINGS FOR DIFFERENT SYSTEMS AND MATERIALS. REVIEW ALL SHEETS AND APPLY NOTES TO RELATED BUILDING COMPONENTS.		

ABBREVIATIONS LEGEND

APPROX.	ACT	BLK	CH	CLG	CONC.	CAU	CPT	C/W	DIA	ELEC	ELEV	EQUIP	EX	FD	FIN	FIN FL	F.F.X.	FRR	FL	GL	GB	INT	JOINT	MAX	MECH	MIN	MISC	MTL	MD	INC	NOM	NIS	OC	OH	ORF	PB	PBD	PLWD	PT	RB	RCP	REQ'D	RO	SM	SPEC	STRUCT	SUSP	S&V	T/O	TPD	TYP	U/S	VCT	VERT	W/	WD	WB	WR	RUBBER BASE REFLECTED CEILING PLAN REQUIRED	ROUGH OPENING	SIMILAR SPECIFICATIONS	STRUCTURAL	SUSPENDED STAIN AND VARNISH	TOP OF TOILET PAPER DISPENSER	TYPICAL UNDERSIDE	VINYL COMPOSITE TILE	VERTICAL	WITH WOOD	WD	WB	WR
APPROXIMATELY	ACTUALLY	BLOCK	CHICK HOOK	CEILING	CONCRETE	COURT	CARPET	COMPLETE WITH	DIAMETER	ELECTRICAL	ELEVATION	EQUIPMENT	EXISTING	FLOOR DRAIN	FINISH	FINISHED FLOOR	FIRE EXTINGUISHER	FIRE RESISTANCE RATING	FLOOR	GLASS / GLAZING	GYPSUM BOARD	INTERIOR	JOINT	MAXIMUM	MECHANICAL	MINIMUM	MISCELLANEOUS	METAL	MASONRY OPENING	NOT IN CONTRACT	NOMINAL	NOT TO SCALE	ON CENTRE	OVERHEAD	OPENING	DOOR OPERATOR PUSH BUTTON	PARTICLE BOARD	PLYWOOD	PAINT	RUBBER BASE REFLECTED CEILING PLAN REQUIRED	ROUGH OPENING	SIMILAR SPECIFICATIONS	STRUCTURAL	SUSPENDED STAIN AND VARNISH	TOP OF TOILET PAPER DISPENSER	TYPICAL UNDERSIDE	VINYL COMPOSITE TILE	VERTICAL	WITH WOOD	WOOD	WHITE BOARD	WASHROOM																			

SYMBOL LEGEND

TAG	DESCRIPTION	TAG	DESCRIPTION	TAG	DESCRIPTION	TAG	DESCRIPTION
M	MECHANICAL TAG SEE MECHANICAL DRAWINGS	101A	DOOR NUMBER	01 FLOOR PLAN	DRAWING TITLE	W10	WALL & PARTITION TAG
E	ELECTRICAL TAG SEE ELECTRICAL DRAWINGS	P.B.	DOOR OPERATOR TAG ACTIVATION BUTTON	01	SECTION TAG	N	NORTH ARROW
M1	MATERIAL TAG	18'-9"	CEILING ELEVATION	01	INTERIOR ELEVATION TAG	5'-7 1/2"	DIAMETER BARRIER FREE TURNING CIRCLE
100	CONSTRUCTION NOTE	OFFICE 102	ROOM NAME ROOM NUMBER	A	INTERIOR ELEVATION TAG		
100	DEMOLITION NOTE	±1'-10"	VERTICAL ELEVATION DATUM				
A	ACCESSORY TAG						

NOTES	PROJECT IDENTIFICATION	DRAWING IDENTIFICATION	ORIENTATION	SUB-CONSULTANT	PRIME CONSULTANT	DISCIPLINE SEAL	DRAWING SUBMISSION(S)	INTERNAL INFO	COPYRIGHT 2019
THE CONTRACTOR SHALL CHECK AND VERIFY ALL DIMENSIONS AND REPORT ANY ERRORS OR OMISSIONS TO THE ARCHITECT PRIOR TO COMMENCING OR PROCEEDING WITH ANY WORK ON THIS PROJECT. ALL DRAWINGS AND SPECIFICATIONS ARE THE PROPERTY OF THE ARCHITECT COPYRIGHT 2019. THESE DRAWINGS AND SPECIFICATIONS ARE DESIGNED FOR THE CLIENT AND THE PROPERTY INDICATED ON THESE DRAWINGS ONLY AND SHALL NOT BE CONSTRUCTED FOR ANY OTHER CLIENT OR ANY OTHER PROPERTY. DO NOT SCALE DRAWINGS.	<p>ST. ANNE CATHOLIC SCHOOL UNIVERSAL WASHROOM 183 SNOW AVE. BLENHHEIM, ONTARIO NOP 1A0</p> <p>DESIGN REVIEW SITE PLAN APPROVAL BUILDING PERMIT BIDS DOCUMENTS CONTRACT DOCUMENTS CONSTRUCTION DOCUMENTS AS-BUILT DOCUMENTS</p>	<p>GENERAL INFORMATION HOARDING PLAN</p>			<p>67 KING STREET WEST, CHATHAM ON N7M 1C7 TEL . 519.397.0943 EMAIL . email@roastudio.com</p>		<p>MM-DD-YY</p> <p>2 ISSUED FOR BIDS 05-31-19</p> <p>1 ISSUED FOR CLIENT REVIEW 05-28-19</p> <p>NO. DESCRIPTION DATE</p>	<p>ARCHITECTURE</p> <p>PROJECT ID: ROA19-012 DRAWN BY: J. CASSIDY REVIEWED BY: J. OUELLETTE DATE: 05.31.2019 SCALE: AS NOTED</p>	<p>A001</p>

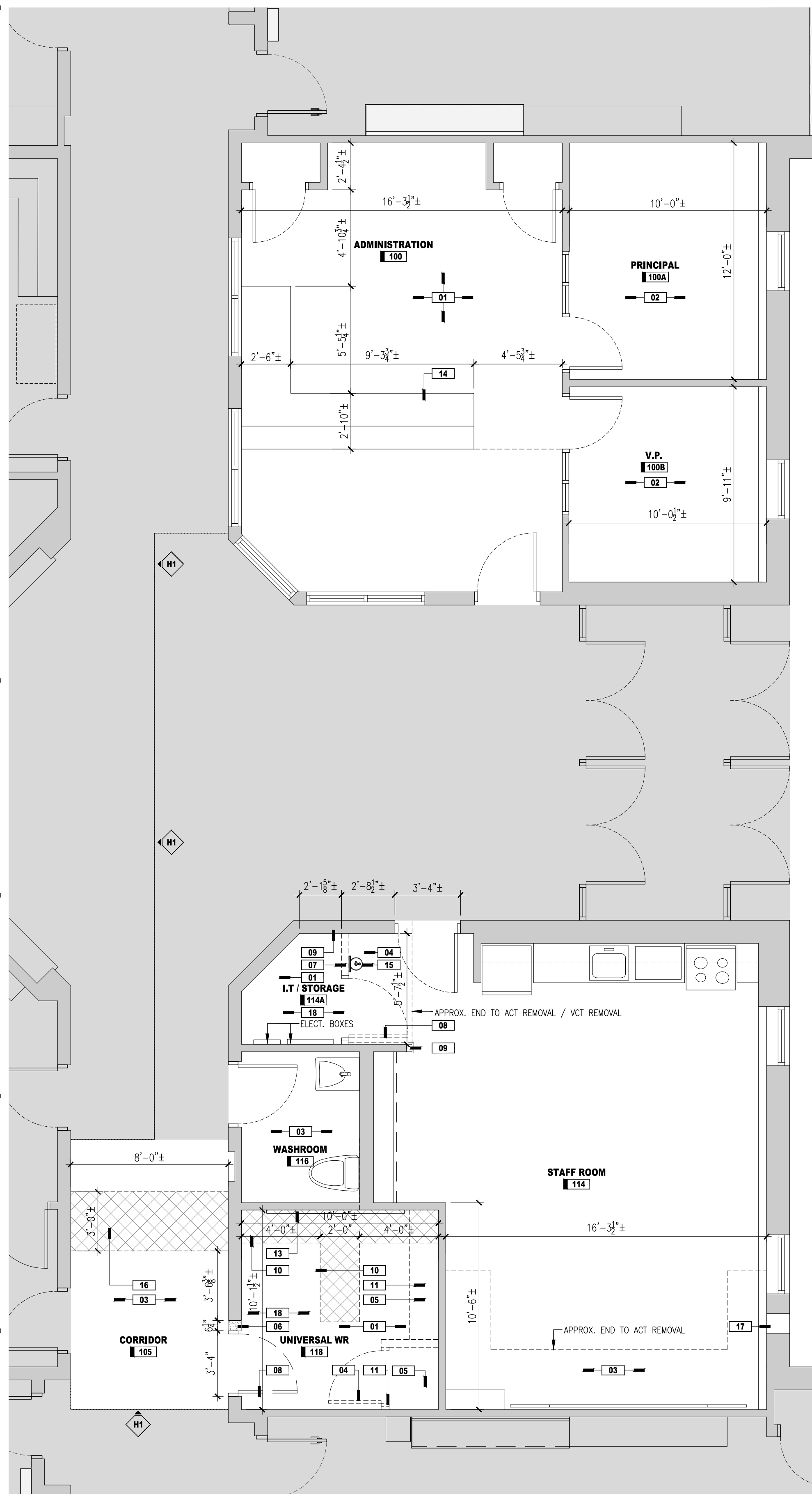

01 PARTIAL DEMOLITION FLOOR PLAN

A101 SCALE: 1/4" = 1'-0"

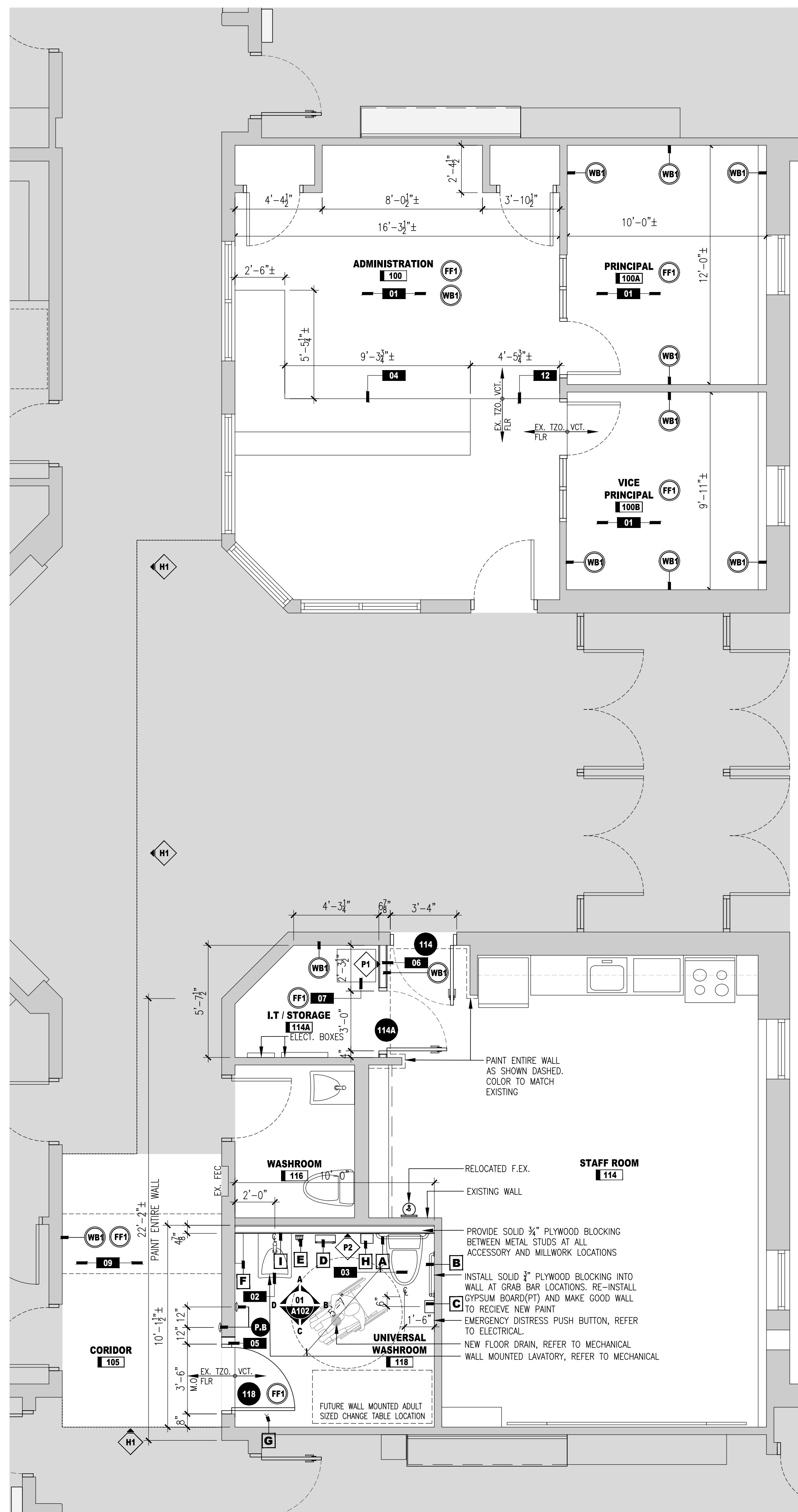

02 PARTIAL FLOOR PLAN

A101 SCALE: 1/4" = 1'-0"

KEYPLAN

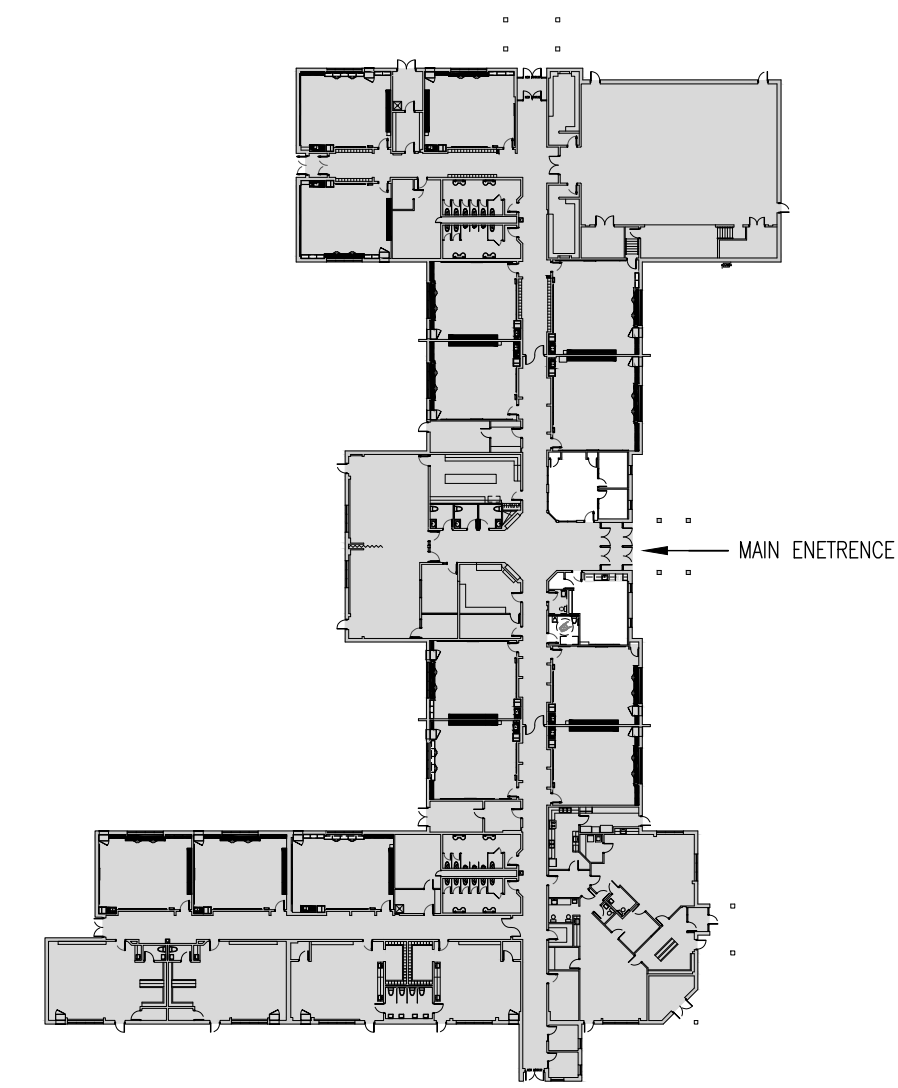

TAG

CONSTRUCTION NOTES

- 01 INSTALL FF1 FLOORING COMPLETE WITH WB1. REFER TO MATERIAL LEGEND.
- 02 INSTALL NEW LAVATORY REFER TO MECHANICAL DRAWINGS FOR INFORMATION.
- 03 INSTALL NEW WATER CLOSET. REFER TO MECHANICAL FOR ADDITIONAL INFORMATION.
- 04 MOVE MILLWORK AS REQUIRED. CONTRACTOR TO PROTECT TO PREVENT DAMAGE, DURING THE DURATION OF CONSTRUCTION.
- 05 TOOTH-IN NEW CONCRETE BLOCK TO MATCH EXISTING. PREP AND MAKE GOOD ENTIRE WALL TO RECEIVE NEW FINISHES.
- 06 GYPSUM BOARD WALL FINISH THAT IS TO TERMINATE AT UNDERSIDE OF EXPOSED METAL DECK IS TO BE SCRIBED TO FIT TIGHT TO DECK PROFILE. REFER TO WALL SECTIONS FOR DIRECTION OF CORRUGATIONS IN METAL DECK.
- 07 RELOCATE SERVER EQUIPMENT, AND SERVER RACK. WORK TO BE DONE BY OWNERS PREFER VENDOR AND PAY FOR BY ALLOWANCE. SEE SPECIFICATIONS.
- 08 RE-INSTALL ACT CEILING SYSTEM AND MODIFY EXISTING ACT GRID AND TILE TO SUIT NEW WALL LOCATION PROVIDE NEW PERIMETER TRACK AT NEW WALL.
- 09 INSTALL NEW TERRAZZO FLOORING. MAKE LEVEL WITH EXISTING TERRAZZO FLOOR. COLOUR TO MATCH EXISTING.
- 10 SUPPLY AND INSTALL NEW ACT CEILING SYSTEM.
- 11 RE-INSTALL EXISTING CEILING TILE AND GRID AFTER THE COMPETITION OF MECHANICAL WORK.

TAG

DEMOLITION NOTES

- 01 REMOVE EXISTING VCT FLOORING C/W ADHESIVE AND RUBBER BASE IN THIS AREA. PATCH, FLASH & PREP SUBFLOOR TO RECEIVE NEW FLOOR FINISH.
- 02 REMOVE EXISTING CARPET FLOORING AND BASE C/W ADHESIVE AND RUBBER BASE IN THIS AREA. PATCH, FLASH & PREP SUBFLOOR TO RECEIVE NEW FLOOR FINISH.
- 03 PARTIALLY REMOVE EXISTING ACT CEILING SYSTEM AS REQUIRED TO INSTALL NEW DUCTWORK. REFER TO MECHANICAL. EXISTING PERIMETER TRACK TO REMAIN. SALVAGE AND STORE EXISTING CEILING TILE FOR REINSTALLATION. DISCONNECT CEILING MOUNTED DEVICES AS REQUIRED.
- 04 REMOVE EXISTING CEILING SYSTEM IN THIS AREA TO SUIT NEW WORK.
- 05 REMOVE EXISTING CABINET AND SHELF. PATCH AND MAKE GOOD EXISTING WALL TO RECEIVE NEW FINISHES. REFER TO ROOM FINISH SCHEDULE.
- 06 REMOVE EXISTING 8" CONC. MASONRY PARTITION COMPLETE AS SHOWN DASHED AS REQ'D FOR NEW DOOR AND FRAME. PATCH AND MAKE GOOD EX. CONCRETE SLAB TO RECEIVE NEW FINISHES. TOOTH-IN NEW BLOCK AT ADJOINING REMAINING WALLS WITH BULL NOSE BLOCK AT JAMB. REPAIR TZO. FLOOR AND BASE AT NEW JAMB.
- 07 REMOVE EXISTING STUD PARTITION COMPLETELY. PATCH AND MAKE GOOD EXISTING WALL | CONC. SLAB TO RECEIVE NEW WORK AND FINISHES.
- 08 REMOVE AND DISPOSE OF EXISTING DOOR SLAB AND EXISTING HOLLOW METAL FRAME.
- 09 REMOVE PORTION OF RUBBER BASE TO SUIT NEW WORK. RE-INSTALL RUBBER BASE AFTER NEW WORK IS COMPLETE.
- 10 LINE DENOTES APPROXIMATE AREA TO SAW CUT AND REMOVE EXISTING SLAB C/W DUCTWORK. REFER TO MECHANICAL. EXISTING PERIMETER TRACK TO REMAIN. SALVAGE AND STORE EXISTING CEILING TILE FOR REINSTALLATION. DISCONNECT CEILING MOUNTED DEVICES AS REQUIRED.
- 11 REMOVE AND RELOCATE EX. SERVER EQUIPMENT, AND SERVER RACK. WORK TO BE DONE BY OWNERS PREFER VENDOR AND PAY FOR BY ALLOWANCE. CONTRACTOR TO PATCH AND MAKE GOOD EXISTING WALLS TO RECEIVE NEW FINISHES. CONTRACTOR TO PATCH EXISTING FLOOR AT I.T. RACK TO RECEIVE NEW FINISH.
- 12 LINE OF VCT REMOVAL. EXISTING TERRAZZO TO REMAIN. FEATHER/GRIND CONCRETE SLAB TO SUIT NEW FLOOR FINISH DEPTH TO MATCH FLUSH WITH EXISTING TERRAZZO FLOOR.
- 13 REMOVE EXISTING CHALKBOARDS COMPLETE. PATCH AND MAKE GOOD EXISTING WALL TO RECEIVE NEW FINISHES.
- 14 EXISTING MILLWORK TO REMAIN. CONTRACTOR TO PROTECT TO PREVENT DAMAGE DURING THE DURATION OF CONSTRUCTION.
- 15 EXISTING FIRE EXTINGUISHERS TO BE REMOVED, PROTECTED AND RE-INSTALLED AFTER COMPLETION OF NEW WORK. (PAINTING, TERRAZZO, CEILING, ETC.). REFER TO NEW PLAN FOR NEW LOCATION.
- 16 REMOVE TERRAZZO FLOORING TO NEAREST JOINT/BAR AS SHOWN HATCHED. SAW CUT CONCRETE AS REQUIRED TO TIE IN NEW PLUMBING LINE. AT COMPETITION OF WORK, SUPPLY AND INSTALL NEW COMPACTED GRANULAR BASE C/W NEW CONC. SLAB TO MATCH EXISTING. INSTALL NEW TERRAZZO FLOOR TO MATCH EXISTING COLOUR. REFER TO MECHANICAL DRAWINGS FOR ADDITIONAL DETAILS.
- 17 SAW CUT AND REMOVE PORTION OF THE EXISTING MASONRY WALL C/W INTERIOR PLASTER FINISH. FOR THE INSTALLATION OF NEW EXHAUST DUCT. REFER TO MECH DRAWINGS. INSTALLATION OF EXTERIOR LOUVER AS PER MECH DRAWINGS INSTALL SEALANT AROUND PERIMETER OF LOUVER. SPRAY FOAM INSULATION AROUND EXTERIOR WALL DUCT PENETRATION.
- 18 REMOVE AND DISPOSE OF EXISTING ACT CEILING SYSTEM COMPLETE. REFER TO MECHANICAL. DISCONNECT CEILING MOUNTED DEVICES AS REQUIRED.

NOTES

THE CONTRACTOR SHALL CHECK AND VERIFY ALL DIMENSIONS AND REPORT ANY ERRORS OR OMISSIONS TO THE ARCHITECT PRIOR TO COMMENCING OR PROCEEDING WITH ANY WORK ON THIS PROJECT. ALL DRAWINGS AND SPECIFICATIONS ARE THE PROPERTY OF THE ARCHITECT COPYRIGHT 2019. THESE DRAWINGS AND SPECIFICATIONS ARE DESIGNED FOR THE CLIENT AND THE PROPERTY INDICATED ON THESE DRAWINGS ONLY AND SHALL NOT BE CONSTRUCTED FOR ANY OTHER CLIENT OR ANY OTHER PROPERTY. DO NOT SCALE DRAWINGS.

PROJECT IDENTIFICATION							
ST. ANNE CATHOLIC SCHOOL UNIVERSAL WASHROOM 183 SNOW AVE. BLENHEIM, ONTARIO NOP 1A0							
DESIGN REVIEW	SITE PLAN APPROVAL	BUILDING PERMIT	BIDS DOCUMENTS	CONTRACT DOCUMENTS	CONSTRUCTION DOCUMENTS	AS-BUILT DOCUMENTS	

DRAWING IDENTIFICATION

PARTIAL DEMOLITION PLAN,
PARTIAL FLOOR PLAN &

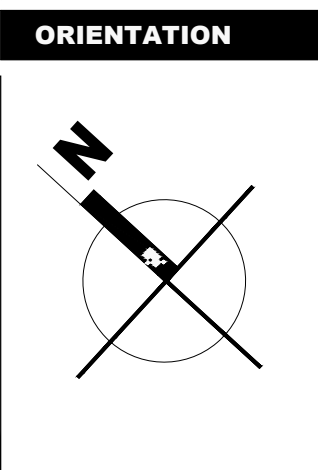

SUB-CONSULTANT

PRIME CONSULTANT

ROA STUDIO

67 KING STREET WEST, CHATHAM ON N7M 1C7
 TEL . 519.397.0943 EMAIL . email@roastudio.com

DISCIPLINE SEAL

DRAWING SUBMISSION(S)		
2	ISSUED FOR BIDS	05-31-19
1	ISSUED FOR CLIENT REVIEW	05-28-19
NO.	DESCRIPTION	DATE

INTERNAL INFO	
ARCHITECTURE	
PROJECT ID	ROA19-012
DRAWN BY	J. CASSIDY
REVIEWED BY	J. QUELLETTE
DATE	05.31.2019
SCALE	AS NOTED

A101

ROA19-012 ST. ANNE CATHOLIC SCHOOL RENOVATIONS

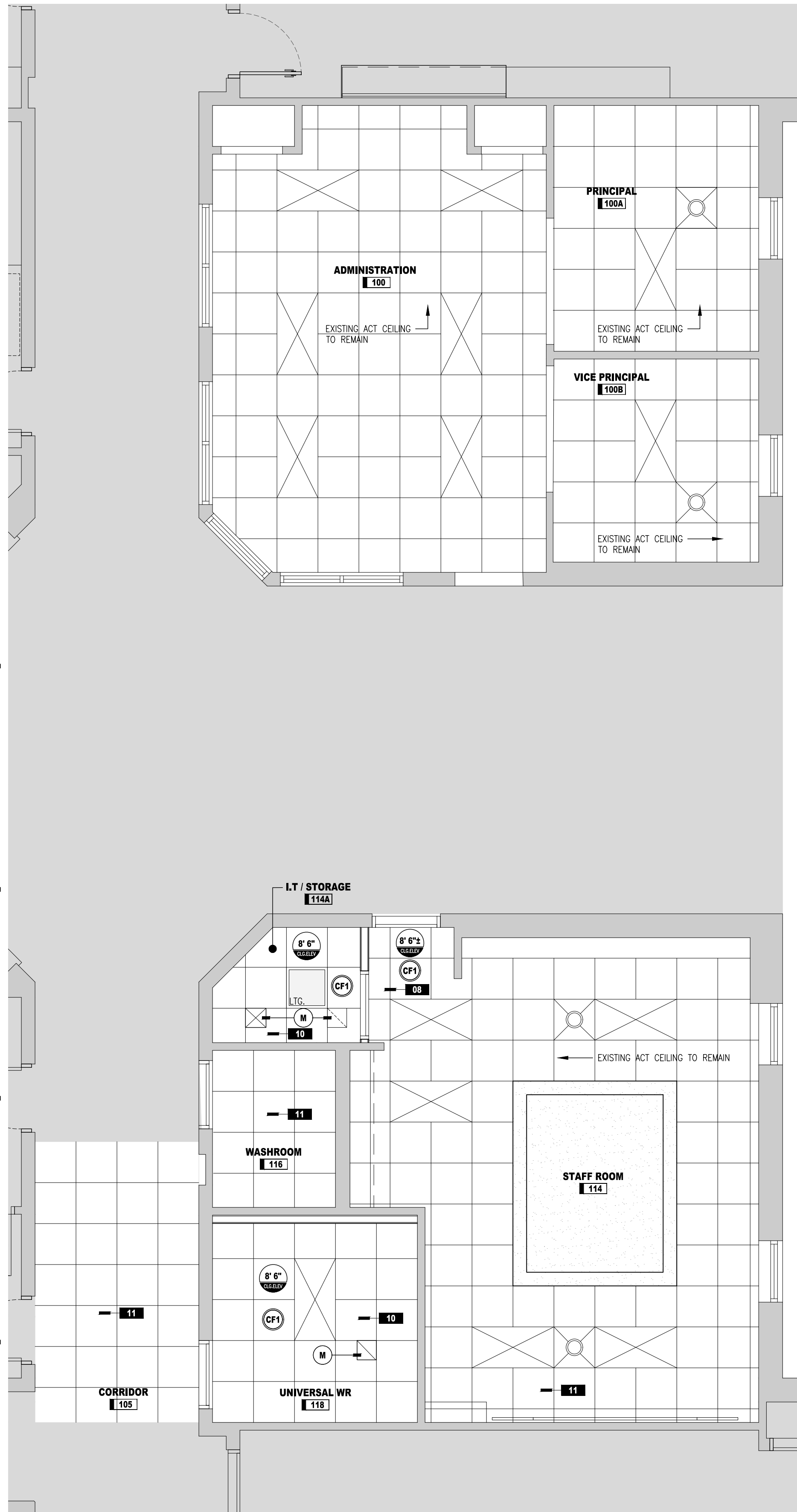

02 PARTIAL REFLECTED CEILING PLAN

A102 SCALE: 1/4" = 1'-0"

FIRST FLOOR ROOM FINISH SCHEDULE

ROOM#	ROOM NAME	FLOOR	BASE	WALLS	FIN	CEILING	FIN	HT	REMARKS
100	ADMINISTRATION	EX FF1	EX WB1	EXISTING	-	EXISTING	-	SEE RCP	-
100A	PRINCIPAL	FF1	WB1	EXISTING	-	EXISTING	-	SEE RCP	-
100B	VICE PRINCIPAL	FF1	WB1	EXISTING	-	EXISTING	-	SEE RCP	-
105	CORRIDOR	EXT/FF2	EX	EXISTING	PT./EXT	EXISTING	-	SEE RCP	PAINT WALL AS NOTED ON PLANS
114	STAFF RM.	FF1/EXT	WB1/EX	EXISTING/G.B	PT./EXT	CF1/EXT	-	SEE RCP	PAINT WALL AS NOTED ON PLANS
114A	LT. CLOSET	FF1	WB1	EXISTING/G.B	PT.	CF1	-	SEE RCP	PAINT ENTIRE ROOM
118	UNIVERSAL W/R	FF1	WB1	EXISTING/G.B	PT.	CF1	-	SEE RCP	PAINT ENTIRE ROOM

DOOR & FRAME SCHEDULE

DOOR#	ROOM NAME	FRAME	DOOR	REMARKS
114	STAFF RM.	EX. HM. - - - -	EXISTING	- - - - - NO CHANGE
114A	LT. CLOSET	A HM. PT. - - - -	3'-0" x 7'-0" x 1 1/2"	A HM. PT. - - - -
118	UNIVERSAL W/R	B HM. PT. - - - -	3'-2" x 7'-0" x 1 1/2"	A HM. PT. - - - - PROVIDE BARRIER FREE DOOR OPERATOR

MATERIALS SCHEDULE

FLOOR FINISH LEGEND

TAG	PRODUCT	FINISH	BASED ON
(F1)	VCT	WAX & SEAL	-
(F2)	TERRAZZO	MATCH EXISTING	-

CEILING FINISH LEGEND

TAG	PRODUCT	FINISH	BASED ON
(CF)	2'X2' ACOUSTIC TILE	RADAR NON-DIRECTIONAL	CGC PRODUCT

WALL FINISH LEGEND

TAG	PRODUCT	FINISH	BASED ON
(WF2)	NEW GYPSUM BOARD	PAINT	-
(WF3)	EXISTING CONC. BLOCK	PAINT	-
(WF4)	EXISTING GYPSUM BOARD	PAINT	-

WALL BASE

TAG	PRODUCT	FINISH	BASED ON
(WB)	4" RUBBER BASE	MATCH EXISTING	-

GENERAL DOOR & FRAME NOTES

No.	DOOR & FRAME NOTES	No.	DOOR & FRAME NOTES
1.	ALL THRESHOLDS TO BE BRUSHED ALUMINUM & MAX 1/2" IN HEIGHT.	3.	ALL EXTERIOR DOORS TO BE WEATHER STRIPPED
2.	ALL DOOR HANDLES SHALL BE LEVERS UNLESS OTHERWISE NOTED, MOUNT AS SPECIFIED IN HARDWARE SCHEDULE.	4.	ALL DOORS IN RATED ASSEMBLIES SHALL HAVE APPROVAL AGENCY RATING LABELS. DOOR FRAMES AND HARDWARE TO BE LISTED TO MATCH DOORS.

DOOR ELEVATIONS

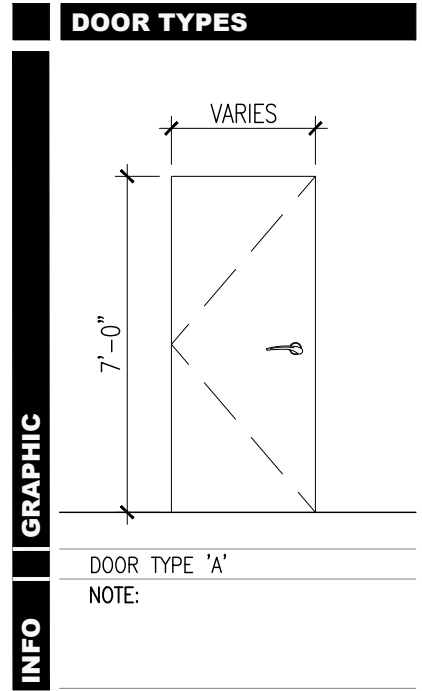

FRAME ELEVATIONS

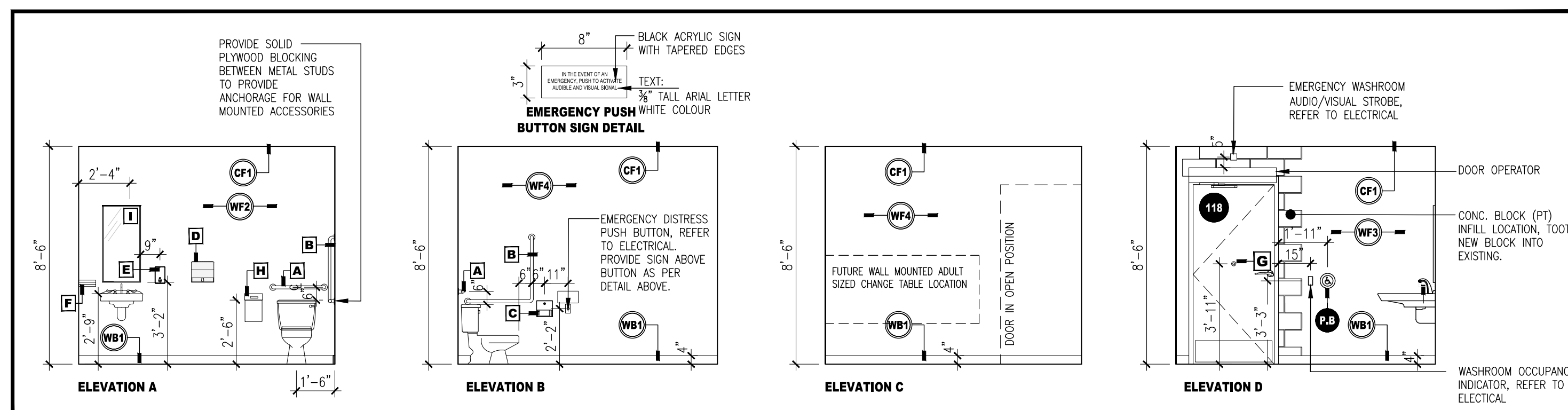
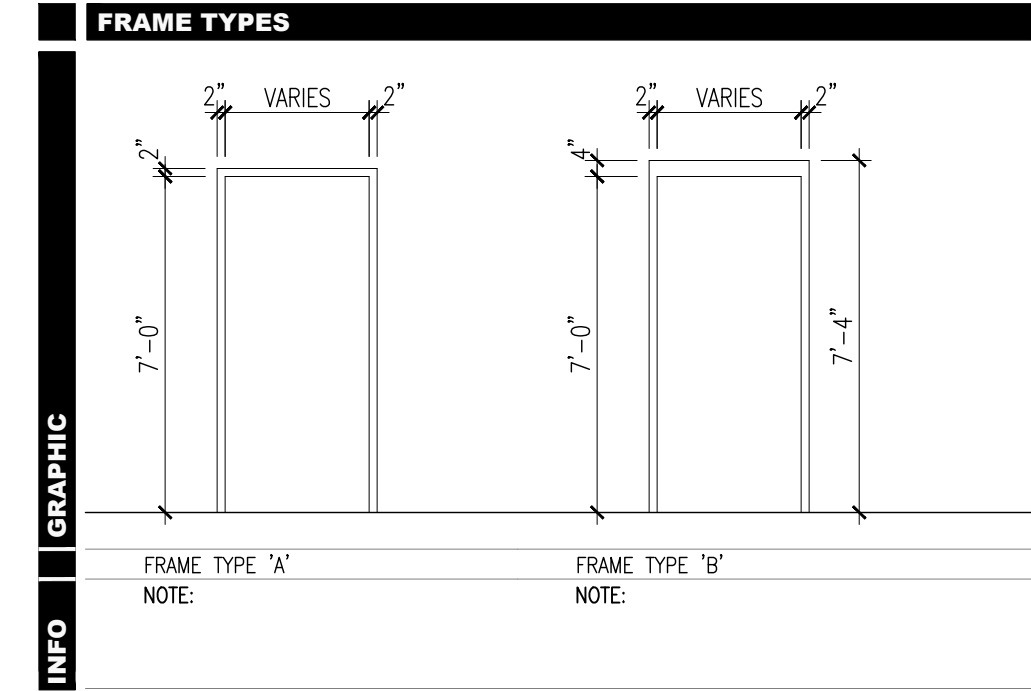

01 INTERIOR ELEVATIONS : UNIVERSAL WASHROOM 118

A102 SCALE: 1/4" = 1'-0"

ACCESSORIES SCHEDULE SUMMARY

DESCRIPTION	MODEL #	SYMBOL	NOTES
1 GRAB BAR 1	FROST CODE 1001	A	
1 L SHAPED GRAB BAR	FROST CODE 1003	B	
1 TOILET TISSUE DISPENSER	-	C	OWNER SUPPLIED / CONTRACTOR INSTALLED
1 PAPER TOWEL DISPENSER	-	D	OWNER SUPPLIED / CONTRACTOR INSTALLED
1 SOAP DISPENSER	-	E	OWNER SUPPLIED / CONTRACTOR INSTALLED
1 HEAVY DUTY SHELF	FROST CODE 950-18"	F	
1 COAT HOOK	-	G	BREAK AWAY HOOK
1 FEMINE NAPKIN DISPOSAL	FROST CODE 622	H	
1 MIRROR 1 (18"x36")	ASI CODE 0620	I	

<p>NOTES</p> <p>THE CONTRACTOR SHALL CHECK AND VERIFY ALL DIMENSIONS AND REPORT ANY ERRORS OR OMISSIONS TO THE ARCHITECT PRIOR TO COMMENCING OR PROCEEDING WITH ANY WORK ON THIS PROJECT. ALL DRAWINGS AND SPECIFICATIONS ARE THE PROPERTY OF THE ARCHITECT COPYRIGHT 2019. THESE DRAWINGS AND SPECIFICATIONS ARE DESIGNED FOR THE CLIENT AND THE PROPERTY INDICATED ON THESE DRAWINGS ONLY AND SHALL NOT BE CONSTRUCTED FOR ANY OTHER CLIENT OR ANY OTHER PROPERTY. DO NOT SCALE DRAWINGS.</p>	<p>PROJECT IDENTIFICATION</p> <p>ST. ANNE CATHOLIC SCHOOL UNIVERSAL WASHROOM 183 SNOW AVE. BLENHEIM, ONTARIO NOP 1A0</p>	<p>DRAWING IDENTIFICATION</p> <p>PARTIAL REFLECTED CEILING PLAN WASHROOM ELEVATIONS SCHEDULES</p>	<p>ORIENTATION</p>	<p>SUB-CONSULTANT</p>	<p>PRIME CONSULTANT</p> <p>67 KING STREET WEST, CHATHAM ON N7M 1C7 TEL . 519.397.0943 EMAIL . email@roastudio.com</p>	<p>DISCIPLINE SEAL</p>	<p>DRAWING SUBMISSION(S)</p> <table border="1"> <thead> <tr> <th>NO.</th> <th>DESCRIPTION</th> <th>DATE</th> </tr> </thead> <tbody> <tr> <td>2</td> <td>ISSUED FOR BIDS</td> <td>05-31-19</td> </tr> <tr> <td>1</td> <td>ISSUED FOR CLIENT REVIEW</td> <td>05-28-19</td> </tr> </tbody> </table>	NO.	DESCRIPTION	DATE	2	ISSUED FOR BIDS	05-31-19	1	ISSUED FOR CLIENT REVIEW	05-28-19	<p>INTERNAL INFO</p> <p>ARCHITECTURE</p> <p>PROJECT ID: ROA19-012 DRAWN BY: J. CASSIDY REVIEWED BY: J. OUELLETTE DATE: 05.31.2019 SCALE: AS NOTED</p>	<p>COPYRIGHT 2019</p>
	NO.	DESCRIPTION	DATE															
2	ISSUED FOR BIDS	05-31-19																
1	ISSUED FOR CLIENT REVIEW	05-28-19																
<p>DESIGN REVIEW</p> <p>SITE PLAN APPROVAL</p> <p>BUILDING PERMIT</p> <p>BIDS DOCUMENTS</p> <p>CONTRACT DOCUMENTS</p> <p>CONSTRUCTION DOCUMENTS</p> <p>AS-BUILT DOCUMENTS</p>																		

MECHANICAL SPECIFICATIONS

SECTION 15000 - GENERAL SPECIFICATIONS

1.0 GENERAL

1.1 THIS GENERAL SPECIFICATION APPLIES TO ALL MECHANICAL WORK INCLUDING HVAC, AND PLUMBING. SEE THE RESPECTIVE SECTIONS.

1.2 ALL WORK SHALL COMPLY WITH APPLICABLE CODES, REGULATIONS, ORDINANCES, STANDARDS, GOOD PRACTICE AND MANUFACTURERS' RECOMMENDATIONS FOR NEW, RENOVATION AND/OR DEMOLITION WORK. THIS INCLUDES BUT NOT LIMITED TO ASHRAE, SMACNA, NFPA, OBC, OFC, CAN/CSA, LOCAL CODES, REGULATIONS & BYLAWS.

1.3 INSTALLATION SHALL BE COMPLETE AND FULLY FUNCTIONAL. PROVIDE ALL MATERIALS, EQUIPMENT, ACCESSORIES, CONSUMABLES, LABOR, SUPERVISION, TOOLS, SERVICES, ETC. AS REQUIRED.

1.4 PROVIDE THE FOLLOWING SYSTEMS AS PART OF THIS CONTRACT: HVAC, PLUMBING AND ASSOCIATED CONTROLS.

1.5 ARRANGE FOR ALL PERMITS, APPROVALS, EXAMINATION AND INSPECTION SERVICES. PAY ALL REQUIRED FEES. PROVIDE ALL THE NECESSARY APPLICATIONS, DOCUMENTATION, DRAWINGS AND SPECIFICATIONS.

1.6 PRIOR TO TENDERING, EXAMINE THE SITE. ALL DRAWINGS AND SPECIFICATIONS AND REPORT ALL CONFLICTS, DISCREPANCIES TO THE CONSULTANT FOR CLARIFICATION AND / OR CORRECTION. NO ALLOWANCE SHALL BE MADE FOR FAILURE TO DO SO.

1.7 TENDER DRAWINGS: DRAWINGS ARE DIAGRAMMATIC AND INDICATE THE GENERAL ARRANGEMENTS OF MECHANICAL SYSTEMS AND WORK INCLUDED. DO NOT SCALE DRAWINGS. OBTAIN DIMENSIONS FROM ENGINEER'S PLANS, MANUFACTURER'S SHOP DRAWINGS AND ON-SITE INSPECTIONS.

1.8 ELECTRICAL WORK: ALL WIRING AND CONDUIT FOR POWER AND CONTROL SHALL BE BY ELECTRICAL DIVISION, EXCEPT FOR WIRING, CONDUIT AND CONNECTIONS BELOW 50V WHICH ARE RELATED TO AUTOMATIC CONTROL SYSTEMS SHALL BE BY CONTROLS CONTRACTOR.

1.9 SUBMIT SHOP DRAWINGS AND PRODUCT DATA FOR ALL EQUIPMENT. THE SHOP DRAWINGS SHALL INDICATE THE MANUFACTURER, MODEL, AND PHYSICAL, ELECTRICAL, MECHANICAL, AND PERFORMANCE CHARACTERISTICS.

1.10 PROTECT NEW & EXISTING WORK AND STRUCTURE FROM DAMAGE, WEATHER, TEMPERATURE AND HUMIDITY EXTREMES.

1.11 DEMOLITION AND RENOVATIONS:

1.11.1 COORDINATE AND SCHEDULE WORK WITH OWNER AND OTHER TRADES TO MINIMIZE CONFLICTS, DELAYS, INTERFERENCE AND DISRUPTION OF EXISTING SERVICES, OPERATIONS & ADJACENT BUILDING AREAS. PREVENT SPREAD OF DUST, ODOURS, AND NOISE TO PERMIT CONTINUED USE & OCCUPANCY. PERFORM NOISY, MALODOROUS, DUSTY, AND/OR DISRUPTIVE WORK ON DAYS AND TIMES AGREED WITH OWNER.

1.11.2 DO NOT DISABLE OR DISRUPT BUILDING FIRE OR LIFE SAFETY SYSTEMS WITHOUT PRIOR WRITTEN NOTICE TO OWNER. DO NOT CLOSE OR OBSTRUCT EGRESS FROM BUILDING(S) OR SITE EXIT.

1.11.3 REMOVE DESIGNATED BUILDING MATERIALS, EQUIPMENT, PIPING, FIXTURES & CONSTRUCTION COMPLETE WITH ALL COMPONENTS, ACCESSORIES, ETC.

1.11.4 DEMOLISH IN AN ORDERLY AND CAREFUL MANNER. PROTECT EXISTING STRUCTURE. KEEP PROJECT SITE IN A CLEAN AND ORDERLY MANNER. REMOVE TRASH AT REGULAR INTERVALS TO PREVENT BUILDUP OF RUBBISH.

1.11.5 REMOVE, CUT, AND PATCH WORK TO MINIMIZE DAMAGE WALLS, FLOORS, CEILINGS AND ROOFS AS REQUIRED. CONSULT ARCHITECT AND ENGINEER FIRST. RESTORE DAMAGED PRODUCTS AND FINISHES TO ORIGINAL CONDITION IN TEXTURE AND APPEARANCE. MAINTAIN FIRE/SMOKE RATING INTEGRITY OF RATED ASSEMBLIES.

1.11.6 IF HAZARDOUS / CONTAMINATED MATERIALS ARE ENCOUNTERED, STOP WORK AND INFORM GENERAL CONTRACTOR, ARCHITECT & CONSULTANT FOR FURTHER DIRECTION.

1.12 PROVIDE SCHEDULE 40 PIPE SLEEVES AT PENETRATIONS THROUGH MASONRY AND CONCRETE, OR FIRE RATED ASSEMBLIES.

1.13 PROVIDE FIRE STOPPING MATERIAL AT PENETRATIONS THROUGH FIRE RATED ASSEMBLIES TO MAINTAIN FIRE RATING INTEGRITY.

1.14 PROVIDE ACCESS FOR SERVICING EQUIPMENT AS RECOMMENDED BY THE MANUFACTURER.

1.15 INSTALL EQUIPMENT, DUCTS AND PIPES PARALLEL TO OR PERPENDICULAR TO BUILDING LINES.

1.16 PROVIDE SPACE, UNIONS AND FLANGES FOR EASE OF MAINTENANCE, DISASSEMBLY AND REMOVAL OF EQUIPMENT.

1.17 PIPE PAINTING AND IDENTIFICATION SHALL COMPLY WITH STANDARDS. IDENTIFY PIPES AT EVERY BRANCH AND AT EVERY EQUIPMENT. USE PLASTIC COATED CLOTH MATERIAL WITH COLORS AND IDENTIFICATION AND WATER PROOF ADHESIVE.

1.18 RECORD ALL DEVIATIONS FROM THE CONSTRUCTION DRAWINGS. ON PROJECT COMPLETION, PROVIDE REPRODUCIBLE "AS BUILT" DRAWINGS SHOWING WORK AS ACTUALLY INSTALLED.

1.19 CONDUCT TESTS IN ACCORDANCE WITH APPLICABLE CODES AND STANDARDS.

1.20 PROVIDE 3 COPIES OPERATING AND MAINTENANCE MANUALS FOR HVAC, AND PLUMBING SYSTEMS. INCLUDE: "AS BUILT" DRAWINGS, SHOP DRAWINGS, PRODUCT DATA, OPERATING & MAINTENANCE INSTRUCTIONS, TROUBLE SHOOTING, PART LISTS, T & B REPORT, WARRANTIES, WIRING AND CONTROL DIAGRAMS.

1.21 FURNISH A GUARANTEE COVERING ALL EQUIPMENT, COMPONENTS, ACCESSORIES AND SYSTEMS FOR MINIMUM OF ONE YEAR FROM THE DATE OF ACCEPTANCE.

2.0 PRODUCTS

2.1 HANGERS & SUPPORTS - HANGERS SHALL BE IN ACCORDANCE WITH ANSI B31.1. HORIZONTAL PIPE HANGERS SHALL BE CLEVIS TYPE CARBON STEEL WITH BLACK FINISH. FINISH SHALL BE COPPER OR PLASTIC FOR DIRECT SUPPORT COPPER TUBE OR PIPE. RODS SHALL BE BLACK CARBON STEEL THREADED RODS WITH LOCK NUTS, AND PROTECTION SADDLES (FOR INSULATED PIPES).

2.2 INSULATION SHALL BE FIBERGLASS, NON-COMBUSTIBLE WITH VAPOUR BARRIER JACKET AND FIRE RETARDANT ADHESIVE. FLAME SPREAD AND SMOKE DEVELOPED RATINGS SHALL NOT EXCEED 25/00 BASED ON THE STANDARDS OF FIRE HAZARD CLASSIFICATION FOR BUILDING MATERIALS. INSULATION SHALL BE FIBERGLAS CANADA LIMITED OR APPROVED EQUAL.

2.3 VALVES, FITTINGS & FLANGE INSULATION SHALL BE MOLDED AND FABRICATED INSULATION SEGMENTS OF A THICKNESS EQUAL TO THAT OF THE PIPE.

3.0 EXECUTION

3.1 ALL EQUIPMENT CONNECTIONS SHALL HAVE ISOLATION VALVES AND UNIONS OR FLANGED CONNECTIONS.

3.2 VALVE SIZES SHALL BE THE SAME LINE SIZE UNLESS NOTED OTHERWISE. PROVIDE ISOLATING VALVES IN EACH BRANCH FROM THE MAIN LINE AND WHERE SHOWN. PROVIDE ISOLATING VALVES FOR ALL EQUIPMENT.

3.3 PROVIDE SHOCK ABSORBERS UPSTREAM OF ALL SOLENOID VALVES, FLUSH VALVES AND/OR OTHER QUICK CLOSING VALVES.

3.4 ALL PIPE, FITTINGS, FIXTURES AND EQUIPMENT SHALL BE RIGIDLY SUPPORTED. ALL FASTENINGS TO BUILDING STRUCTURE SHALL BE FIRMLY MADE WITHOUT DAMAGE TO BUILDING STRUCTURE.

3.5 PIPES SHALL BE CONCEALED IN WALLS, CEILINGS, CHASES, PIPE SHAFTS, ETC. EXCEPT IN MECHANICAL ROOMS, SERVICE ROOMS AND AS INDICATED OTHERWISE.

3.6 PROVIDE DIELECTRIC UNIONS BETWEEN PIPES OF DISSIMILAR MATERIAL.

3.7 PROVIDE CHROME PLATED EPOXY COATINGS AT ALL POINTS WHERE PIPES PASS THROUGH FINISHED WALLS, CEILINGS OR FLOORS.

3.8 SUPPORT CAST IRON PIPES AT 1.5 M MAXIMUM INTERVALS; COPPER PIPES AT 2.4 M MAXIMUM INTERVALS; STEEL PIPE AT 3 M MAXIMUM INTERVALS.

SECTION 15400 - PLUMBING

1.0 GENERAL

1.1 SEE SECTION 15000 ABOVE.

2.0 PRODUCTS

2.1 PLUMBING FIXTURES:

2.1.1 WC1 FLOOR MOUNTED TANK TYPE TOILET, VITREOUS CHINA, TANK TYPE: AMERICAN STANDARD #215AA.074.020, "CADET PRO RIGHT HEIGHT ELONGATED", 419 MM HIGH TOILET, VITREOUS CHINA, FLOOR MOUNTED, 6 L (1.6 US GAL) PER FLUSH, TWO (2) PIECE, ELONGATED BOWL, CADET FLUSHING SYSTEM WITH POWERWASH RIM SIPHON FLUSHING SYSTEM, RAISED SANITARY BAR AND FOUR (4) POINTS TANK STABILIZATION, CENTOCO #820STS.001, EXTRA HEAVY DUTY TOILET SEAT, SOLID PLASTIC, OPEN FRONT WITH COVER, MCGUIRE #LHF165LKN3, POLISHED BRASS TOILET SUPPLY, PROVIDE FLOOR FLANGE, (SAME MATERIAL AS THE CONNECTING PIPE DRAIN), WITH ALL BRASS BOLTS AND WITH RUBBER GASKET. PROVIDE BOLTED TANK COVER PROVIDE TRIP LEVER ON OPEN SIDE OF TOILET (WIDE SIDE) TO MEET LOCAL CODES.

2.1.2 1.1L1 BASIN - AMERICAN STANDARD #9141 011 020 "WHEELCHAIR" BASIN, WHITE FINISH, AMERICAN STANDARD #7500.175.002, "MONTERREY", TWO HANDLES FAUCET, 1.9 LPM (0.5 GPM) PRESSURE COMPENSATING AERATOR, AMERICAN STANDARD MONTERREY #7500.175.002 TWO HANDLES FAUCET, POLISHED CHROME FINISH, 4" (102 MM) CENTRESET, BRASS, 1.9 LPM (0.5 GPM) PRESSURE COMPENSATING AERATOR, RIGIDSWING GOOSENECK SPOUT, 127 MM (5") PROJECTION REACH, 4" (102 MM) LONG VANDAL RESISTANT RED AND BLUE INDEXED WRIST BLADE HANDLES, LESS DRAIN AND POP-UP HOLE. LAWLOR #670-86620, POINT OF USE THERMOSTATIC WATER MIXING VALVE, INTEGRAL CHECKS HOUSED IN RECESSED BOX, S.S. COVER, MCGUIRE #155WC OFFSET OPEN GRID DRAIN, MCGUIRE #LHF165LKN3, POLISHED BRASS FAUCET SUPPLIES, MCGUIRE #8872C, P-TRAP, MCGUIRE #PWRWRAP #PW200DWC SANITARY COVERING, WATTS #WCA-411-WC, BASIN CARRIER.

2.2 WATER HAMMER ARRESTOR - WATTS DRAINAGE SERIES 06; COPPER CONSTRUCTION, PISTON TYPE SIZED TO PDI WH-201, PRECHARGED SUITABLE FOR OPERATION IN TEMPERATURE RANGE 33°F TO 100°F (0.5°C TO 82°C) AND MAXIMUM 150 PSIG (1000 KPA) WORKING PRESSURE.

2.3 FLOOR DRAINS: LAQUERED OR EPOXY COATED CAST IRON BODY WITH ANCHOR FLANGE, SEEPAGE COLLECTION SUMP, NICKEL, BRONZE STRAINER, CAST IRON REVERSIBLE MEMBRANE CLAMP WITH PRIMARY AND SECONDARY WEEPHOLES. WATTS FD-100-C

2.4 TRAP SEAL PRIMER INDIVIDUAL TRAPS: AUTOMATIC, CAST BRASS BODY, RENEWABLE DISC AND SEAT RINGS, VACUUM BREAKER, AND REMOVABLE COVER. WATTS MS-810.

2.5 CLEAN OUT: INTERIOR FINISHED FLOOR AREAS: WATTS DRAINAGE MODEL CO-200-R, CO-200-U, LAQUERED CAST IRON BODY WITH ANCHOR FLANGE, REVERSIBLE CLAMPING COLLAR, THREADED TOP ASSEMBLY, AND ROUND GASKETED SCORED COVER IN SERVICE AREAS AND ROUND GASKETED DEPRESSION COVER TO ACCEPT FLOOR FINISH IN FINISHED FLOOR AREAS.

2.6 PLUMBING PIPING

2.6.1 SANITARY DRAINAGE PIPING - BURIED: 2" (50 MM) AND SMALLER DIAMETER, HARD TEMPER COPPER PIPE, TYPE L; 3" (75 MM) AND LARGER DIAMETER, CAST IRON SOIL PIPE, NO-HUB MECHANICAL JOINT WITH NEOPRENE GASKETS AND STAINLESS STEEL PIPE CLAMPS.

2.6.2 SANITARY DRAINAGE PIPING - ABOVE GRADE: 2" (50 MM) AND SMALLER DIAMETER, HARD TEMPER COPPER TUBE, TYPE DWV, SOLDERED, WITH WROUGHT COPPER OR COPPER DRAINAGE FITTINGS OR CAST BRASS DRAINAGE FITTINGS; 3" (75 MM) AND LARGER DIAMETER, CAST IRON SOIL PIPE, NO-HUB MECHANICAL JOINT WITH NEOPRENE GASKETS AND STAINLESS STEEL PIPE CLAMPS WITH CAST IRON DRAINAGE FITTINGS.

2.6.3 VENT PIPING - BURIED: 2" (50 MM) AND SMALLER DIAMETER, HARD TEMPER COPPER PIPE, TYPE L, TO ASTM B42-87, WITH WROUGHT COPPER OR COPPER ALLOY SOLDER JOINT TO ANSI B16.29-73 OR CAST BRASS SOLDER JOINT TO CSA B158.1-1976.

2.6.4 VENT PIPING - ABOVE GRADE: 2" (50 MM) AND SMALLER DIAMETER, HARD TEMPER COPPER TUBE, TYPE DWV 3" (75 MM) AND LARGER DIAMETER, CAST IRON SOIL PIPE, NO HUB MECHANICAL JOINT WITH CAST IRON DRAINAGE FITTINGS

2.6.5 WATER PIPING - ABOVE GRADE: COPPER TUBING 3" (75MM) AND SMALLER TYPE L, HARD DRAIN FITTINGS; CAST COPPER ALLOY OR WROUGHT COPPER AND BRONZE.

2.6.6 ISOLATING VALVES: UP TO AND INCLUDING 2" (50 MM); MANUFACTURER: KITZ #9AMLL, CONSTRUCTION: MSS SP-110, 1034 KPA (150 PSIG) 600 WOG, FORGED BRASS, TWO PIECE BODY, STAINLESS STEEL BALL AND STEM, FULL PORT, VIRGIN PTFE SEATS AND STEM PACKING OR DOUBLE O-RING, BLOW-OUT PROOF STEM, LEVER HANDLE, STEM EXTENSIONS FOR INSULATED PIPING, SOLDER ENDS.

2.7 INSULATION

2.7.1 DOMESTIC WATER PIPING INSULATION: GLASS FIBRE; MANUFACTURER: OWENS CORNING FIBERGLAS, INSULATION: ASTM C547; RIGID MOULDED, NON-COMBUSTIBLE VAPOUR BARRIER JACKET ASTM C921, WHITE KRAFT PAPER REINFORCED WITH GLASS FIBRE YARN AND BONDED TO ALUMINIZED FILM. SECURE WITH SELF SEALING LONGITUDINAL PIPS AND BUTT STRIPS. SECURE WITH OUTWARD CLINCH EXPANDING STAPLES AND VAPOUR BARRIER MASTIC, TIE WIRE, 0.05" (1.3 MM) STAINLESS STEEL WITH TWISTED ENDS ON MAXIMUM 12" (300 MM) CENTRES. MINIMUM 1" THICKNESS.

SECTION 15600 - HEATING, VENTILATING & AIR CONDITIONING

1.0 GENERAL

1.1 SEE SECTION 15000 ABOVE.

2.0 PRODUCTS

2.1 DUCTWORK & ACCESSORIES:

2.1.1 DUCTS AND FITTINGS SHALL BE FABRICATED FROM GALVANIZED SHEET STEEL, LOCK FORMING QUALITY TO ASTM A525 WITH Z275 ZINC COATING. DUCT CONSTRUCTION SHALL BE PER SMACNA FOR 2 INCHES W.C. PRESSURE CLASS WITH MAXIMUM LEAKAGE RATE PER CODES. DUCT CONNECTIONS AND TRANSVERSE JOINTS SHALL BE SEALED WITH SEALANT AND TAPE.

2.1.2 DUCT MATERIAL THICKNESS SHALL BE AS FOLLOWS: MAXIMUM SIZE OR DIAMETER THICKNESS UP TO 300 MM 26 U.S. STANDARD GAUGE

301 TO 750 MM 24 U.S. STANDARD GAUGE

751 TO 1000 MM 22 U.S. STANDARD GAUGE

2.1.3 FLEXIBLE DUCT: INSULATED, UL-181EIT CLASS I AIR DUCT, NFPA 90A COMPLIANT, LOW TO MEDIUM PRESSURE APPLICATION, ALUMINUM FOIL, FIBERGLASS AND ALUMINIZED POLYESTER LAYERS, CORROSION RESISTANT GALVANIZED STEEL HELIX, FIRE RETARDANT REINFORCED VAPOUR BARRIER, FIBERGLASS INSULATION BLANKET, FACTORY WRAPPED, 5 FEET MAXIMUM LENGTH. FLEXMASTER 58 OR APPROVED EQUAL.

2.1.4 VOLUME DAMPERS (SINGLE BLADE UP TO 12 INCHES DEEP) SHALL BE SAME MATERIAL AS DUCT, NEXT GAUGE HEAVIER THAN DUCT, V GROOVE STIFFENED, LOCKING QUADRANT, SHAFT EXTENSION, BRONZE END BEARINGS, CHANNEL FRAME AND ANGLE STOP. DAMPERS FOR DUCTS GREATER THAN 12 INCHES DEEP SHALL BE PARALLEL BLADE, PIN IN BRONZE BUSHING, LOCKING QUADRANT, SHAFT EXTENSION, ANGLE STOP, CHANNEL FRAME INTERCONNECTED. BLADES UP TO 30 INCHES IN LENGTH SHALL HAVE A MAXIMUM WIDTH OF 10 INCHES, BLADES LONGER THAN 30 INCHES SHALL HAVE A MAXIMUM WIDTH OF 12 INCHES. KERR HUNT OR APPROVED EQUAL.

2.1.5 FIRE DAMPERS SHALL BE FACTORY FABRICATED GALVANIZED STEEL, CHANNEL FRAME, CURTAIN TYPE, LOW RESISTANCE TYPE B, INTERLOCKED BLADES, 160 DEGREES F FUSIBLE LINK, UL LISTED AND LABELED FOR 1 1/2 HOUR RATING. FUSIBLE LINKS FOR 105 DEGREES F, 162 DEGREES F OR 265 DEGREES F, SHALL BE PROVIDED AS INDICATED ON DRAWINGS. RUSKIN, CONTROLLED AIR OR APPROVED EQUAL.

2.1.6 STRAP HANGERS SHALL BE FABRICATED WITH THE SAME MATERIAL AS DUCT. THREADED RODS WITH STEEL ANGLES SHALL BE USED FOR DUCTS 20 INCHES AND LARGER. RODS AND ANGLES SHALL BE GALVANIZED-STEEL. HANGER CONFIGURATION AND SPACING SHALL CONFORM TO SMACNA STANDARDS. HANGER ATTACHMENTS SHALL BE MANUFACTURED CONCRETE INSERTS, EXPANSION SHIELDS AND/OR BOLTED STEEL CLAMPS.

2.2 DIFFUSERS, GRILLES & REGISTERS

2.2.1 CEILING DIFFUSERS: FIXED PATTERN, SQUARE CONE STEEL CONSTRUCTION, 12 INCHES X 12 INCHES FACE, ROUND INLET, OFF WHITE BAKED ENAMEL FINISH, MOUNTING TYPE TO MATCH CEILING. FINISH SHALL BE AS SELECTED BY ARCHITECT. EH PRICE SC0 OR APPROVED EQUAL.

2.2.2 RETURN EXHAUST GRILLES SHALL BE 1/2 IN X 1/2 IN X 1/2 IN ALUMINUM GRID EGG CRATE CORE, ALUMINUM BORDER AND FRAME, T BAR LAY IN TYPE, OFF WHITE BAKED ENAMEL FINISH. SEE DRAWINGS FOR SIZE AND TYPE. E. H. PRICE 80 SERIES OR APPROVED EQUAL.

2.3 CEILING FANS: CEILING MOUNTED EXHAUST FANS, CENTRIFUGAL DIRECT DRIVE, FAN HOUSING OF HEAVY-GAUGE GALVANIZED STEEL, LINED WITH 1/2 INCH (13 MM) ACOUSTICAL INSULATION, OUTLET DUCT COLLAR, BACKDRIFT DAMPER, HORIZONTAL OR VERTICAL DISCHARGE, DESIGNER GRILLE, MOTOR DISCONNECT PLUG-IN TYPE, MOTOR VIBRATION ISOLATORS, FAN WHEEL FORWARD-CURVED CENTRIFUGAL, DYNAMICALLY BALANCED, AMCA CERTIFIED RATINGS SOUND AND AIR PERFORMANCE SEAL, UL/CUL LISTED. ACCEPTABLE MANUFACTURE: GREENHECK MODELS SP-A OR APPROVED EQUAL.

3.0 EXECUTION

3.1 DUCT SIZE CHANGES SHALL HAVE THE SAME FRICTION DROP PER 100 FT AS THE DUCT SHOWN ON DRAWINGS. DUCT ASPECT RATIO SHALL NOT EXCEED 4 TO 1. CONSULT ENGINEER BEFORE CHANGING DUCT SIZE OR LOCATION.

3.2 SEAL DUCT CONNECTIONS AND TRAVERSE JOINTS WITH SEALANT AND TAPE.

3.3 PROVIDE FIRE DAMPERS WITH STEEL ANGLES AROUND PERIMETER AND ACCESS DOORS

3.4 INSULATE ALL DUCTS AND PLENUMS HANDLING OUTSIDE AIR WITH 2 INCHES (50 MM) FIBERGLASS FOIL FACED VAPOUR SEAL DUCT INSULATION 31 DENSITY. EXHAUST DUCTS SHALL BE INSULATED WITH 2 IN. (50 MM) FIBERGLASS FOIL FACED VAPOUR SEAL INSULATION UP TO 7 FEET (2 METERS) FROM OUTSIDE WALL.

LEGEND - PLUMBING	
SYMBOL	DESCRIPTION
	EXISTING PIPING
	DOMESTIC COLD WATER PIPING
	DOMESTIC COLD WATER PIPING
	DOMESTIC HOT WATER PIPING
	DOMESTIC HOT WATER RECIRC. PIPING
	VENT PIPING
	SANITARY PIPING ABOVE FLOOR
	SANITARY PIPING BELOW GRADE OR FLOOR
	STORM PIPING ABOVE FLOOR
	STORM PIPING BELOW GRADE OR FLOOR
	PIPING TO BE REMOVED
	CONNECTION OF NEW AND EXISTING PIPE
	CAPPED PIPE
	FLOOR DRAIN
	ROOF DRAIN
	CLEANOUT IN FLOOR
	CLEANOUT IN LINE OR STACK
	ISOLATION VALVE
	CHECK VALVE
	VENT THROUGH ROOF
	CIRCUIT BALANCING VALVE
	PIPE DOWN
	PIPE UP
	PIPE UP & DOWN
	DENOTES EXISTING
	FIRE EXTINGUISHER

LEGEND - HVAC	
SYMBOL	DESCRIPTION
	EXISTING PIPING
	EXISTING ITEM TO BE REMOVED
	PIPING RISER UP
	PIPING DROP
	PIPING CONNECTION (FROM BELOW)
	ISOLATING (SHUT-OFF) VALVE
	CIRCUIT BALANCING VALVE
	CONNECT TO EXISTING
	SUPPLY AIR DIFFUSER (SQUARE)
	RETURN EXHAUST GRILLE
	FIRE DAMPER
	VOLUME DAMPER
	THERMOSTAT
	UNDER CUT DOOR
	EXISTING ITEM TO REMAIN
	EXISTING SUPPLY DUCT
	EXISTING RETURN DUCT
	EXISTING TOILET EXHAUST DUCT
	DENOTES EXISTING

MECHANICAL DRAWING LIST	
M001	LEGEND, SPECIFICATIONS & NOTES
M01	DEMOLITION FLOOR PLAN - PLUMBING

GENERAL NOTES	
1.	VERIFY ALL CEILING ELEVATIONS, TYPES & FINISHES WITH ARCHITECTURAL.
2.	PENETRATIONS OF CONCRETE SHALL BE SAW-CUT OR CORE DRILLED. IMPACT HAMMERS ARE NOT ALLOWED.
3.	COORDINATE WORK WITH ALL TRADES THROUGH THE GENERAL CONTRACTOR PRIOR TO INSTALLATION OF ANY EQUIPMENT, DUCTWORK, PIPING AND CONTROLS.
4.	REVIEW ALL TRADE DRAWINGS & INSPECT SITE TO DETERMINE FULL EXTENT OF PROJECT PRIOR TO BID.
5.	CAP ALL SERVICES THAT REMAIN AFTER DEMOLITION.
6.	EXISTING MECHANICAL UTILITIES / SERVICES SHOWN ON DRAWINGS WERE TAKEN FROM AVAILABLE DRAWINGS & SITE OBSERVATIONS. VERIFY EXACT SIZE & LOCATION OF ALL EXISTING SERVICES ON SITE & REMOVE ALL REDUNDANT SERVICES / UTILITIES WITHIN THE CONSTRUCTION AREAS.
7.	COORDINATE WITH ARCHITECTURAL TRADES FOR THE INSTALLATION OF ALL MECHANICAL ITEMS REQUIRING ACCESS, INSPECTION, SERVICING & MAINTENANCE. IDENTIFY ACCESS DOOR SIZES, LOCATIONS & FINISHES FOR ACCESSIBILITY ON SUBMITTAL DRAWINGS FOR REVIEW & APPROVAL. MINIMUM 12"x12" ACCESS DOOR FOR HAND ENTRY. OTHERS SUFFICIENT SIZE FOR THEIR INTENDED PURPOSE.
8.	CHECK & VERIFY LOCATIONS OF ALL PIPES, DUCTS, EQUIPMENT, COMPONENTS, ACCESSORIES, ETC. WITH ALL OTHER TRADES TO PREVENT INTERFERENCE & DELAY. REMOVAL AND/OR RELOCATION OF ANY SUCH WORK INTERFERING WITH WORK OF OTHER TRADES SHALL BE THE RESPONSIBILITY OF THE MECHANICAL TRADE CONCERNED UNLESS OTHERWISE APPROVED IN WRITING.

GENERAL DEMOLITION NOTES	
1.	ALL DISTURBED SURFACES AFTER EQUIPMENT AND SYSTEMS REMOVAL OR REROUTING SHALL BE PATCHED WITH APPROPRIATE MATERIAL TO MAINTAIN FIRE SEPARATION & MATCH EXISTING OR NEW FINISHES.
2.	ALL DEMOLISHED / REMOVED FIXTURES & EQUIPMENT REMAIN THE OWNER'S PROPERTY, UNLESS DIRECTED FOR DISPOSAL AT THE OWNER'S DISCRETION. COST OF STORING MATERIALS TO OWNER'S DESIGNATED STORAGE AREA OR DISPOSAL SHALL BE INCLUDED IN CONTRACT.

GENERAL HVAC NOTES	
1.	PROVIDE ALL NECESSARY FINISHING FRAMES, MOUNTING HARDWARE, TRIM PIECES, ACCESSORIES, COMPONENTS, ETC. TO SUIT CEILING TYPES. COORDINATE WITH ARCHITECTURAL TRADES FOR PROPER INSTALLATION & FINISH.
2.	FLEXIBLE DUCTWORK SHALL BE LIMITED TO 5'-0" IN LENGTH TOTAL FOR ANY RUNOUT.

GENERAL PLUMBING NOTES	
1.	PROVIDE CLEANOUTS FOR SANITARY DRAINAGE SYSTEM WHERE & AS REQUIRED BY CODE.
2.	REFER TO ARCHITECTURAL DRAWINGS FOR MOUNTING OF ALL PLUMBING FIXTURES.
3.	ALL SOLDER FOR COPPER PIPING SHALL BE LEAD FREE.
4.	EACH GROUP OF PLUMBING FIXTURES SHALL BE EQUIPPED WITH WATER SHUT-OFF VALVES ABOVE AN ACCESSIBLE CEILING.
5.	ALL PLUMBING FIXTURES & EQUIPMENT SHALL HAVE SHUT-OFF VALVES.
6.	ALL NEW DOW, DWH, AND DHW PIPING TO BE INSULATED.
7.	REFER TO ARCHITECTURAL PLANS FOR EXACT LOCATION OF FURRING WHEN RUNNING PIPING FROM CEILING DOWN TO ROOM TO FIXTURES.
8.	ALL PLUMBING FIXTURES INCLUDING FLOOR DRAINS SHALL BE TRAPPED, VENTED AND PRIMED AS REQUIRED BY ONTARIO BUILDING CODE. CONNECT TO NEAREST EXISTING SERVICES OF SUFFICIENT CAPACITY.
9.	REFER TO SCHEDULES FOR MINIMUM PIPE SIZES TO EACH FIXTURE, EQUIPMENT & APPLIANCE.

NOTES	PROJECT IDENTIFICATION	DRAWING IDENTIFICATION	ORIENTATION	SUB-CONSULTANT	PRIME CONSULTANT	DISCIPLINE SEAL	DRAWING SUBMISSION(S)	INTERNAL INFO	COPYRIGHT 2019
<p>THE CONTRACTOR SHALL CHECK AND VERIFY ALL DIMENSIONS AND REPORT ANY ERRORS OR OMISSIONS TO THE ARCHITECT PRIOR TO COMMENCING OR PROCEEDING WITH ANY WORK ON THIS PROJECT. ALL DRAWINGS AND SPECIFICATIONS ARE THE PROPERTY OF THE ARCHITECT COPYRIGHT 2019. THESE DRAWINGS AND SPECIFICATIONS ARE DESIGNED FOR THE CLIENT AND THE PROPERTY INDICATED ON THESE DRAWINGS ONLY AND SHALL NOT BE CONSTRUCTED FOR ANY OTHER CLIENT OR ANY OTHER PROPERTY. DO NOT SCALE DRAWINGS.</p>	<p>ST. ANNE CATHOLIC SCHOOL INTERNAL WASHROOM 183 SNOW AVE, BLENHEIM, ONTARIO N0P 1A0</p> <p>AS-BUILT DOCUMENTS SITE PLAN APPROVAL BUILDING PERMIT BIDS DOCUMENTS CONTRACT DOCUMENTS CONSTRUCTION DOCUMENTS</p>	<p>MECHANICAL SPECIFICATIONS, LEI ENI, NOTES & REVISIONS</p>							

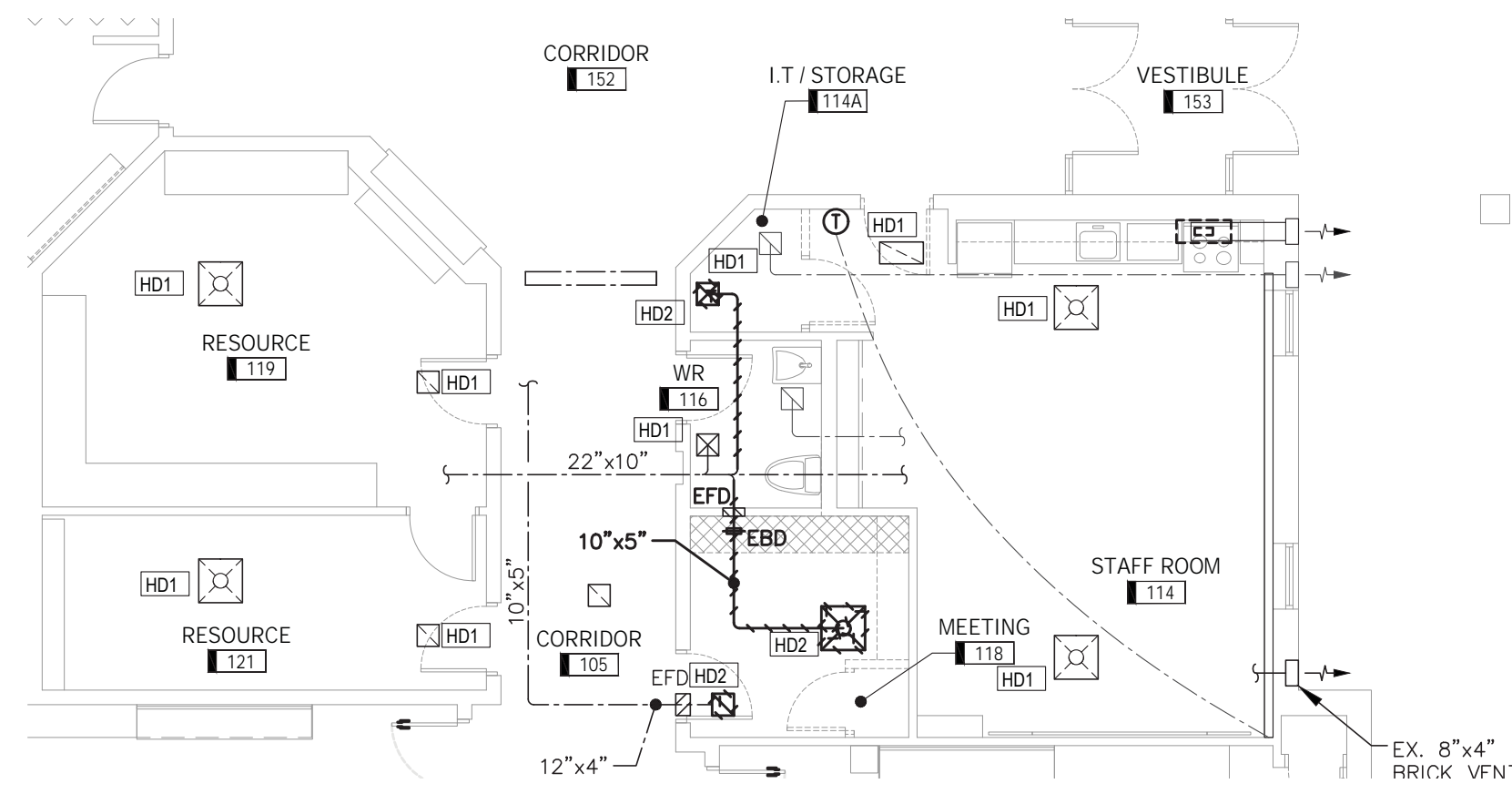

1 DEMOLITION FLOOR PLAN - HVAC
M101 SCALE 1/8" = 1'-0"

HVAC DEMOLITION NOTES (HDX):

- EXISTING DIFFUSERS & GRILLES TO REMAIN.
- DEMOLISH EXISTING DIFFUSER, GRILLE & DUCTWORK, AND INSULATION AS SHOWN. CAP AT TERMINATION POINT.

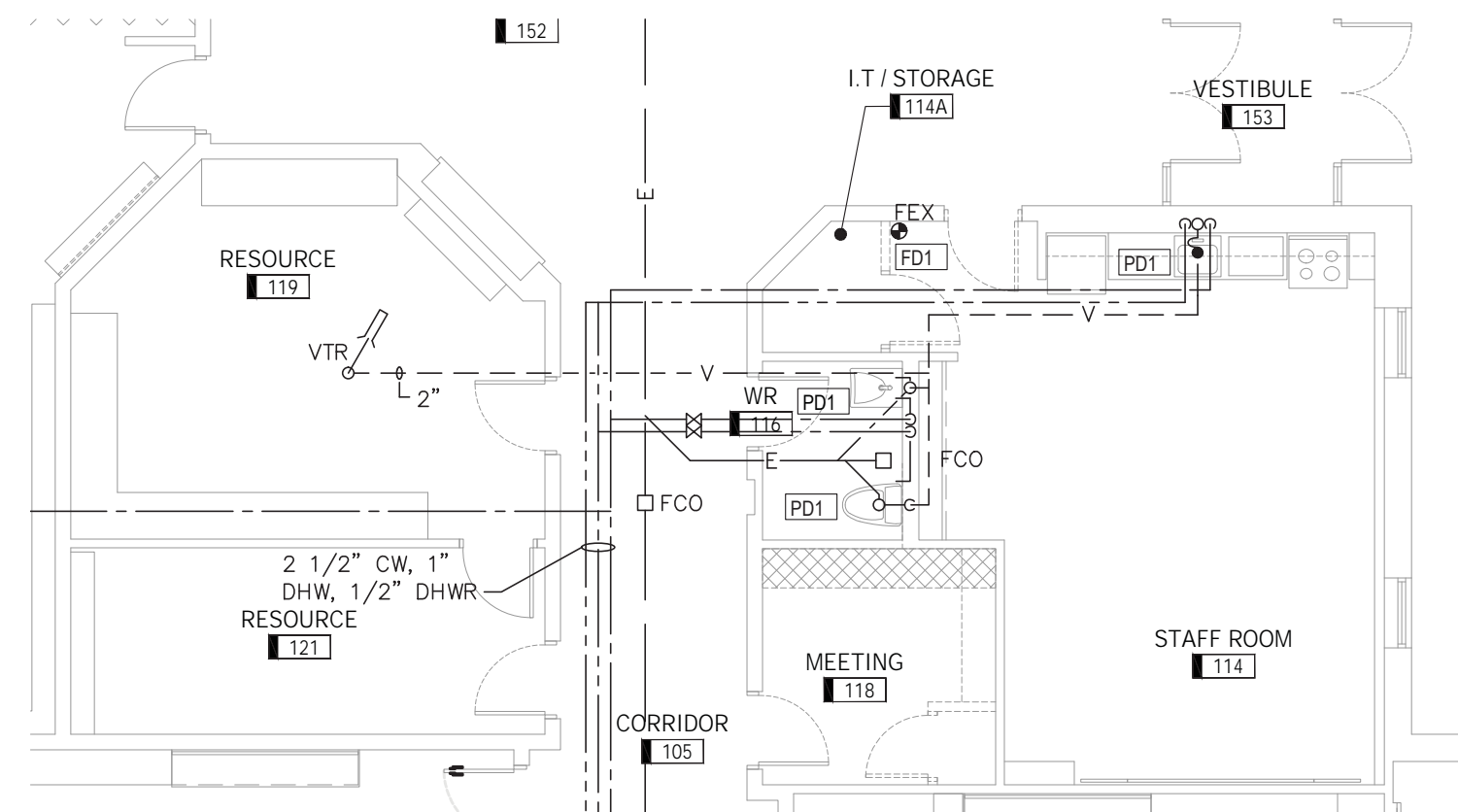

2 DEMOLITION FLOOR PLAN - PLUMBING & FP
M101 SCALE 1/8" = 1'-0"

PLUMBING DEMOLITION NOTES (PDX):

- EX. PLUMBING FIXTURE TO REMAIN.
- RELOCATE FIRE EXTINGUISHER.

FIRE PROTECTION DEMOLITION NOTES (PDX):

- RELOCATE FIRE EXTINGUISHER.

PLUMBING FIXTURE SCHEDULE						
REFER	DESCRIPTION	SAN	VENT	HOT	COLD	NOTES
L1H	LAVATORY - W.H., B.F.	1-1/4"	1-1/4"	1/2"	1/2"	18-1/2" x 17-7/32", 4" BLADE HANDLE, 4" CENTERS
WC1H	WATER CLOSET - F.T., F.M., B.F.	3"	1-1/2"	-	1/2"	LINED TANK

ABBREVIATIONS:
 F.V. - FLUSH VALVE
 W.H. - WALL HUNG
 C.M. - COUNTER MOUNTED
 F.M. - FLOOR MOUNTED
 B.F. - BARRIER FREE

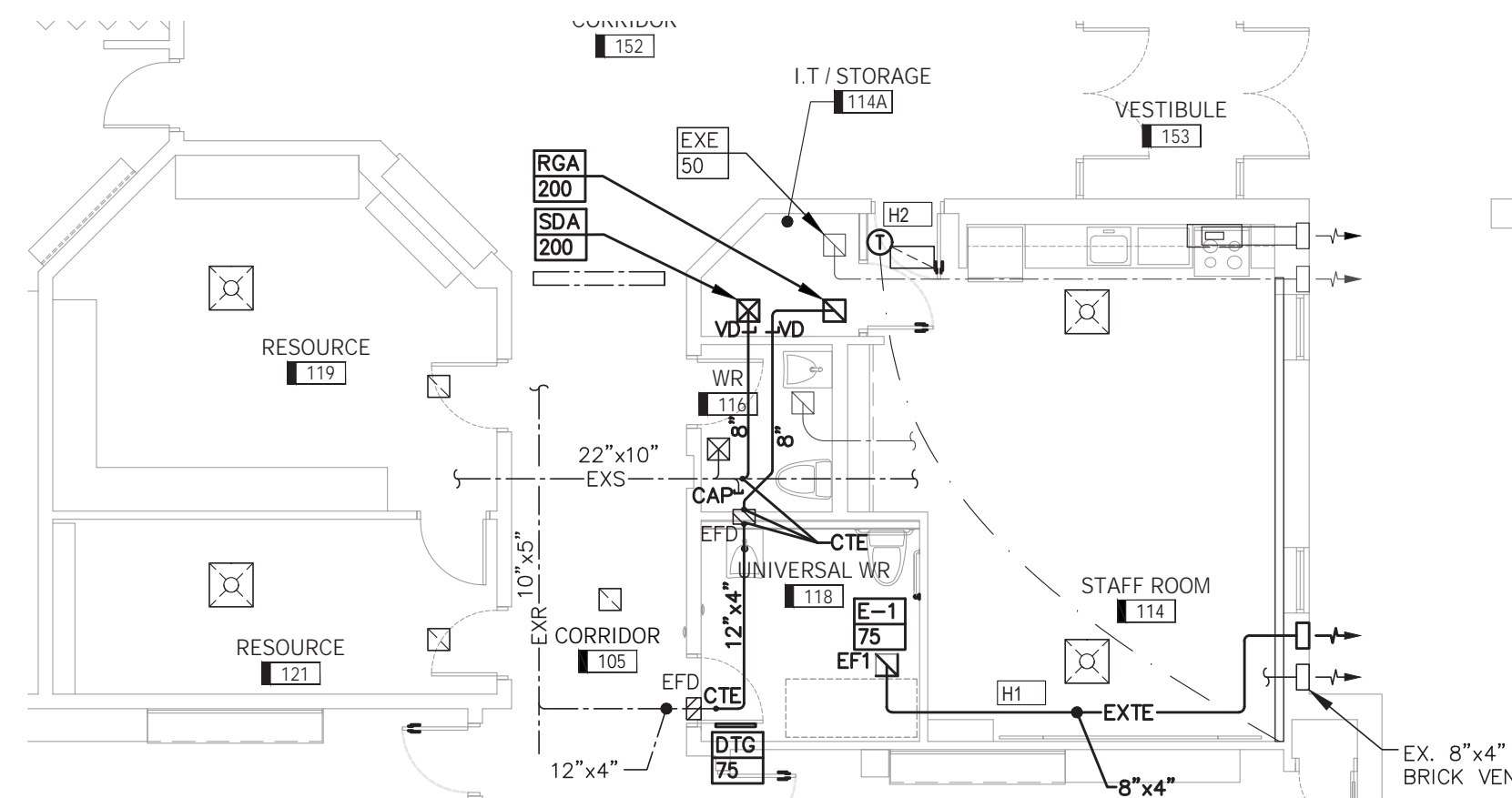

3 FLOOR PLAN - HVAC
M101 SCALE 1/8" = 1'-0"

HVAC NOTES (HX):

- 8"x4" INSULATED EXHAUST DUCT FROM CEILING EXHAUST FAN (EF1) TO 8"x4" BRICK VENT COMPLETE WITH 12" EXTENSION AND BACKDRAFT DAMPER.
- RELOCATE THERMOSTAT AS SHOWN.

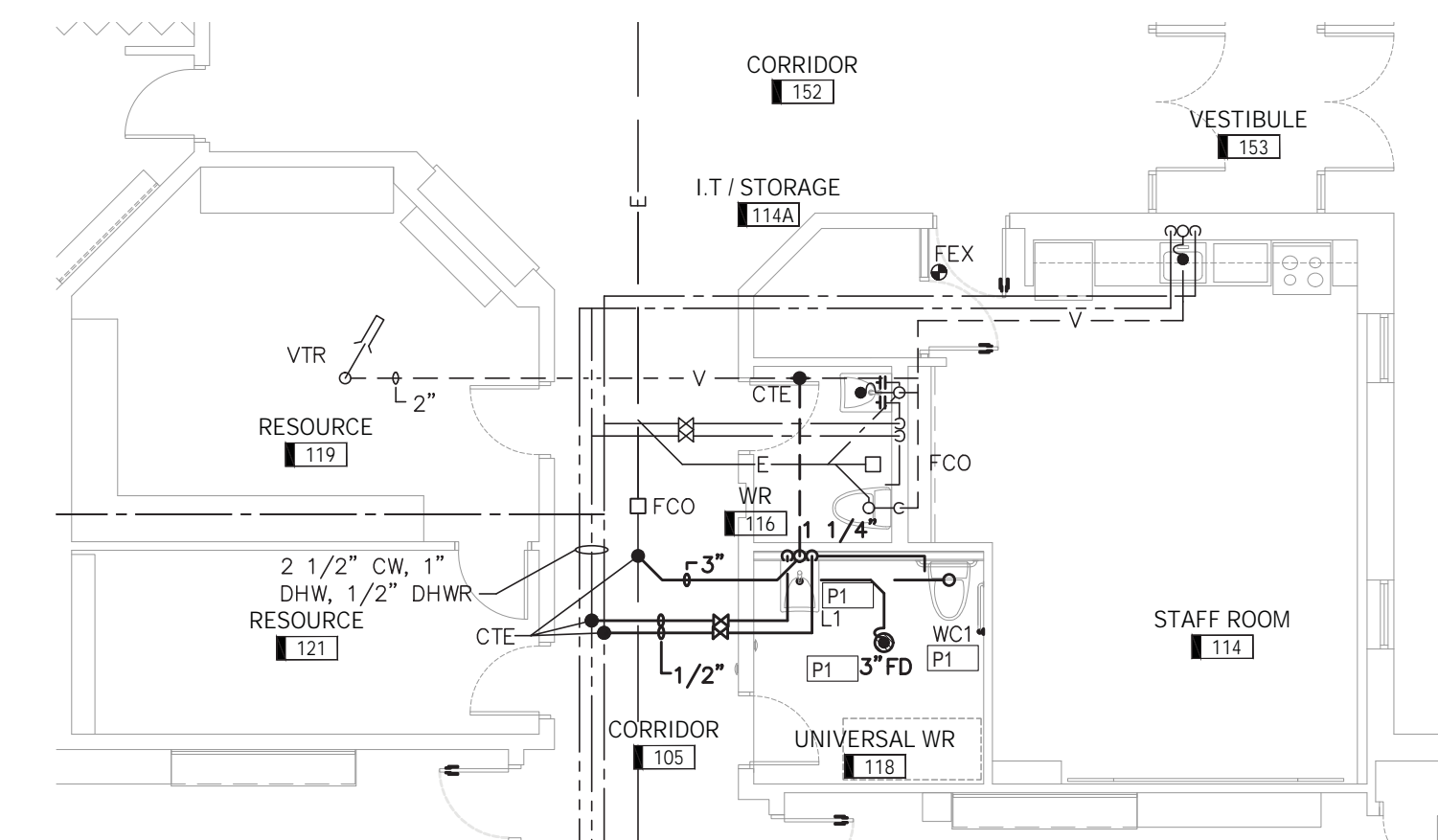

4 FLOOR PLAN - PLUMBING & FP
M101 SCALE 1/8" = 1'-0"

PLUMBING NOTES (PX):

- ALL PLUMBING FIXTURES INCLUDING FLOOR DRAINS SHALL BE TRAPPED, VENTED AND PRIMED AS REQUIRED BY ONTARIO BUILDING CODE. CONNECT TO NEAREST EXISTING VENT BRANCHES OF SUFFICIENT CAPACITY. PROVIDE ALL NEW SHUT-OFF VALVES FOR NEW PLUMBING FIXTURES. REFER TO ARCHITECTURAL PLANS FOR EXACT LOCATION OF FLOORING WHEN RUNNING PIPING FROM CEILING DOWN TO ROOM TO FIXTURES.

NOTES	PROJECT IDENTIFICATION	DRAWING IDENTIFICATION	ORIENTATION	SUB-CONSULTANT	PRIME CONSULTANT	DISCIPLINE SEAL	DRAWING SUBMISSION(S)	INTERNAL INFO	COPYRIGHT 2019												
<p>THE CONTRACTOR SHALL CHECK AND VERIFY ALL DIMENSIONS AND REPORT ANY ERRORS OR OMISSIONS TO THE ARCHITECT PRIOR TO COMMENCING OR PROCEEDING WITH ANY WORK ON THIS PROJECT. ALL DRAWINGS AND SPECIFICATIONS ARE THE PROPERTY OF THE ARCHITECT COPYRIGHT 2019. THESE DRAWINGS AND SPECIFICATIONS ARE DESIGNED FOR THE CLIENT AND THE PROPERTY INDICATED ON THESE DRAWINGS ONLY AND SHALL NOT BE CONSTRUCTED FOR ANY OTHER CLIENT OR ANY OTHER PROPERTY. DO NOT SCALE DRAWINGS.</p>	<p>ST. ANNE CATHOLIC SCHOOL UNIVERSAL WASHROOM 183 SNOW AVE, BLENHEIM, ONTARIO NOP 1A0</p> <p>AS-BUILT DOCUMENTS SITE PLAN APPROVAL BUILDING PERMIT BIDS DOCUMENTS CONTRACT DOCUMENTS CONSTRUCTION DOCUMENTS</p>	<p>FLOOR PLANS - MECHANICAL</p>		<p>Jilani and Asuncion Consulting Engineers LONDON, ON 519.902.2956 416.828.4004 WWW.JIACENG.CA JACE #19-011</p>	<p>ROA studio inc. 67 King Street West, Chatham ON N7M 1C7 tel. 519.397.0943 email. info@roastudio.com</p>		<table border="1"> <thead> <tr> <th>NO.</th> <th>DESCRIPTION</th> <th>DATE</th> </tr> </thead> <tbody> <tr> <td>3</td> <td>ISSUED FOR BIDS</td> <td>05-31-2019</td> </tr> <tr> <td>2</td> <td>ISSUED FOR CLIENT REVIEW</td> <td>05-28-2019</td> </tr> <tr> <td>1</td> <td>99% OWNER'S REVIEW</td> <td>05-16-2019</td> </tr> </tbody> </table>	NO.	DESCRIPTION	DATE	3	ISSUED FOR BIDS	05-31-2019	2	ISSUED FOR CLIENT REVIEW	05-28-2019	1	99% OWNER'S REVIEW	05-16-2019	<p>MECHANICAL</p> <p>PROJECT ID: ROA19-012 DRAWN BY: JACE REVIEWED BY: H. ASUNCION DATE: 05.31.2019 SCALE: 1/8"=1'-0"</p>	
NO.	DESCRIPTION	DATE																			
3	ISSUED FOR BIDS	05-31-2019																			
2	ISSUED FOR CLIENT REVIEW	05-28-2019																			
1	99% OWNER'S REVIEW	05-16-2019																			

DEMOLITION NOTES

- DEMOLITION PLANS ARE BASED ON INFORMATION OBTAINED FROM VISUAL INSPECTION DURING SITE SURVEY. NO EXHAUSTIVE FIELD MEASUREMENT AND CIRCUIT TRACING WAS PERFORMED.
- THESE DRAWINGS ARE PROVIDED TO ASSIST THE CONTRACTOR IN DETERMINING THE EXTENT OF DEMOLITION WORK REQUIRED. THE CONTRACTOR IS REQUIRED TO VISIT SITE AND CONFIRM EXTENT OF DEMOLITION WORK REQUIRED AND MAKE ALLOWANCE IN THE TENDER PRICE FOR THE REMOVAL OF ALL ABANDONED SERVICES AND PROTECTION OF EXISTING SERVICES THAT MUST REMAIN.
- ALL ELECTRICAL EQUIPMENT WITHIN THE OUTLINED AREA MUST BE REMOVED INCLUDING ASSOCIATED WIRING BACK TO SOURCE, CONDUIT AND BOXES MUST BE REMOVED TO CONCEALED LOCATION UNLESS OTHERWISE NOTED.
- DISCONNECT ELECTRICAL CONNECTION TO MECHANICAL EQUIPMENT. REMOVE WIRING BACK TO SOURCE AND CONDUIT TO CONCEALED LOCATION. REFER TO MECHANICAL DRAWINGS AND WORK IN CONJUNCTION WITH MECHANICAL CONTRACTOR.
- MAINTAIN ALL EXISTING SERVICES TO AREAS OUTSIDE OF CONSTRUCTION AND ALL SERVICES PASSING THROUGH AREAS OF CONSTRUCTION. ALL EXISTING DEAD WIRING AND CONDUIT IN RENOVATED AREAS SHALL BE REMOVED IN ITS ENTIRETY.
- ELECTRICAL EQUIPMENT AND LIGHTING FIXTURES BEING REMOVED AND NOT BEING REUSED WILL BE STORED ON SITE AND REMAIN THE PROPERTY OF THE OWNER. ANY SUCH EQUIPMENT AND FIXTURE THAT THE OWNER DOES NOT WISH TO RETAIN WILL BE REMOVED FROM SITE AND DISPOSED OF BY THE CONTRACTOR.
- CONTRACTOR TO MAKE NOTE OF THE CIRCUITS TO DEVICES BEING REMOVED AND REUSE THESE CIRCUITS TO WIRE NEW DEVICES.
- REWORK ALL EXISTING WIRING, CONDUIT, ETC. REMAINING IN USE AND FALLING WITHIN EXISTING WALLS WHICH ARE BEING REMOVED, TO NEAREST EXISTING WALLS REMAINING. ALL REWORKED WIRING SHALL BE CONCEALED.
- DISCONNECT AND REMOVE ANY ELECTRICAL EQUIPMENT IN CEILING SPACE OR WALLS THAT CAUSES INTERFERENCES DURING RENOVATION WORK. ALL EQUIPMENT SHALL BE REPLACED AND RECONNECTED UPON COMPLETION OF RENOVATION WORK.

FIXTURE SCHEDULE

NOTES:

- CONTRACTOR AND FIXTURE SUPPLIER ARE RESPONSIBLE TO PROVIDE ALL PLASTER AND FINISHING FRAMES, MOUNTING HARDWARE, AND ACCESSORIES TO SUIT ARCHITECTURAL CEILING SCHEDULE.
- CONTRACTOR AND SUPPLIER ARE RESPONSIBLE TO VERIFY NUMBER OF BALLASTS REQUIRED FOR MULTIPLE SWITCHING OF FIXTURES.
- ALL FLUORESCENT AND HID BALLASTS SHALL BE HPF-90% OR BETTER POWER FACTOR UNLESS OTHERWISE INDICATED.

TYPE	DESCRIPTION	LAMPS	MTG
AA	2X2' LED LUMINAIRE, 1" DEPTH, FLAT PANEL C/W OPAL SMOOTH ACRYLIC DIFFUSER, DIE-FORMED CODE-GAUGE PRE-PAINTED WHITE STEEL, 3500' K LAMPS, 80CRI AND 0-10V DIMMING DRIVER, 120V UNIVERSAL VOLTAGE TO WORK WITH LV DIMMING OR 120V SENSOR. DRYWALL-SURFACE MOUNTED KIT-FACTORY WELDED SEAMS.	3000 LUMEN 27W LED	RECESS IN TBAR
	PHILIPS CAT: 2FXP30L8352DSUNVDM VISIONEERING, CREE, LITHONIA, METALUX OR APPROVED EQUIVALENT.		

GENERAL NOTES

- DO NOT SCALE DRAWINGS FOR INSTALLATION PURPOSES. OBTAIN ALL DIMENSIONS FROM ARCHITECTURAL PLANS, MANUFACTURER'S SHOP DRAWINGS, AND ON SITE INSPECTIONS.
- PRIOR TO INSTALLATION OF BOXES IN WALLS, VERIFY THAT NO INTERFERENCES EXIST. CHECK ARCHITECTURAL PLANS AND ELEVATIONS.
- MECHANICAL AND ELECTRICAL TRADES SHALL WORK IN CONJUNCTION WITH ONE ANOTHER SO AS TO AVOID INTERFERENCES BETWEEN PIPING, DUCTWORK, CONDUIT, LIGHTING FIXTURES, ETC.
- ALL EXISTING DEAD WIRING AND CONDUIT IN RENOVATED AREAS SHALL BE REMOVED IN ITS ENTIRETY WHERE ACCESSIBLE. WHERE NOT ACCESSIBLE, WIRING ONLY SHALL BE REMOVED AND CONDUIT SHALL REMAIN.
- REVIEW ARCHITECTURAL AND MECHANICAL DRAWINGS AND PROVIDE ON SITE INSPECTIONS TO DETERMINE FULL EXTENT OF PROJECT PRIOR TO SUBMITTING BID.

EMERGENCY LIGHTING

PROVIDE EMERGENCY BATTERY UNITS WITH A MINIMUM OF 30 WATTS FOR 90 MINUTES, LOADED TO 80% MAX. Si E WIRE FOR VOLTAGE DROP.

EMERGENCY BATTERY UNIT No.	LIGHTING HEADS (4W LED)	EXIT SIGNS (2W LED)	TOTAL WATTS
EB1	4 (16W)	- (-W)	16W

EXIST. PANEL 'CL2'

WATTS FOR	EXISTING	P	AMP	CCT	CCT	AMP	P	FOR	EXISTING	WATTS
				1	2					
				3	4					
				5	6					
				7	8					
				9	10					
				11	12					
				13	14					
				15	16					
				17	18					
				19	20					
				21	22					
				23	24					
				25	26					
				27	28					
				29	30					
				31	32					
				33	34					
				35	36	15	11	EMERG. CALL SYSTEM-UWR		
				37	38	15	11	B.F. DOOR OPERATOR-UWR		
				39	40			EXISTING		
				41	42			SPACE		

COMPATIBLE BREAKERS AVAILABLE FROM CUTLER-HAMMER TYPE BQL. CONFIRM WITH MANUFACTURER.
L.O. LOCK-ON BREAKER

LEGEND

SYMBOL	DESCRIPTION	MTG HT & 6
	LIGHTING FIXTURE	AS NOTED
	DOWNLIGHTING FIXTURE	AS NOTED
	WALL MOUNTED LIGHTING FIXTURE	AS NOTED
	20A 125V SINGLE POLE SWITCH, \$ ² (TWO POLE), \$ ³ (3-WAY), \$ ⁴ (4-WAY), \$ ^K (KEY OPERATED), \$ ^D (DIMMER), \$ ^{LV} (LOW VOLTAGE) (C/W PILOT LIGHT), \$ ^T (TIMER), \$ ^S (DUAL TECH WALL SWITCH OCCUPANCY SENSOR-120V) (SINGLE GANG), \$ (DOUBLE GANG), # (TRIPLE GANG), # (FOUR GANG), # (FIVE GANG), # (SIX GANG)	1100 (43')
	LOW VOLTAGE DIMMER SWITCH C/W VACANCY DUAL SENSOR	1100 (43')
	120V OCCUPANCY DUAL TECHNOLOGY SENSOR	CEILING
	120V OCCUPANCY DUAL TECHNOLOGY SENSOR	150 (6") BELOW CEILING
	DUAL TECHNOLOGY LINE VOLTAGE CEILING SENSOR	CEILING
	EMERGENCY LIGHTING BATTERY UNIT No. EB1, WITH TWO HEADS	2,286 (90')
	SINGLE HEAD REMOTE EMERGENCY LIGHT	2,286 (90')
	SINGLE HEAD REMOTE EMERGENCY LIGHT, RECESSED	CEILING
	20AMP 125VOLT U-GROUND DUPLEX RECEPTACLE	457 (18')
	ELECTRICAL PANEL	1981 (78') TO TOP
	SYSTEM PANEL OR EXISTING ELECTRICAL PANEL	
	MOTOR CONNECTION (SINGLE OR THREE PHASE)	
	DISCONNECT SWITCH	1270 (50')
	SINGLE FACE CLOCK	
	THERMOSTAT WALL BOX AND 3/4" CONDUIT WITH PULLWIRE TO ACCESSIBLE CEILING	1200 (47')
	INTERCOM SYSTEM SPEAKER C/W REMOTE CALL SWITCH, PROVIDE 3/4" CONDUIT AND PULLWIRE TO ACCESSIBLE CEILING SPACE	1270 (50')
	JUNCTION BOX (REFER TO DRAWINGS)	
	FIRE ALARM STROBE	2,286 (90')
	HEAT DETECTOR - RATE OF RISE & FIXED TEMP	CEILING
	FIRE ALARM BELL (150mm DIAMETER UNLESS OTHERWISE NOTED)	
	EMERGENCY CALL SYSTEM PUSH BUTTON BY WATER CLOSET/TOILET	1100 (43')
	EMERGENCY CALL SYSTEM AUDIBLE/VISUAL ANNUNCIATOR IN WR	1525 (60')
	EMERGENCY CALL SYSTEM SIGN	1340 (53')
	EMERGENCY CALL SYSTEM HORN/STROBE, CORRIDOR SIDE	2440 (96')
	EMERGENCY CALL SYSTEM POWER SUPPLY IN TYPE 1 JUNCTION BOX	ABOVE CEILING
	SINGLE PUSHBUTTON STATION	1040 (41')
	LOCK FOR UNIVERSAL WR DOOR	
	INTERCOM SYSTEM SPEAKER	CEILING
ABBREVIATIONS:		
CL	CEILING MOUNTED	
E	EXISTING TO REMAIN	
GF	GROUND FAULT INTERRUPTING	
REL	RELOCATE	
REM	REMOVE	
REPL	REPLACE	
TR	TAMPER RESISTANT	
WP	WEATHER PROOF	

ELECTRICAL DRAWING LIST

E001	LEGEND, NOTES, SCHEDULES, ELECTRICAL SPECIFICATION
E101	PARTIAL FLOOR PLANS - DEMOLITION, LIGHTING, POWER SYSTEMS, UNIVERSAL WR DETAIL

ELECTRICAL SPECIFICATIONS

- THIS SPECIFICATIONS DESCRIBE EQUIPMENT AND MATERIALS TO BE INCLUDED IN THE WORK. ELECTRICAL DRAWINGS SHALL BE READ IN CONJUNCTION WITH ARCHITECTURAL, STRUCTURAL AND MECHANICAL DRAWINGS. THESE SPECIFICATIONS APPLY TO AND GOVERN ALL SECTIONS OF ELECTRICAL WORK, INCLUDING TELECOMMUNICATION AND ELECTRONIC SAFETY AND SECURITY SECTIONS.
- OWNER/CONSULTANT, PROVIDE WRITTEN GUARANTEE.
- OBTAIN AND PAY FOR PERMITS REQUIRED BY THE ELECTRICAL SAFETY AUTHORITY AND LOCAL INSPECTION AUTHORITIES FOR THIS WORK. PRESENT FINAL CERTIFICATES TO CONSULTANT AND/OR OWNER.
 - CARRY OUT ALL WORK IN ACCORDANCE WITH OESC (ONTARIO ELECTRICAL SAFETY CODE) REGULATIONS INCLUDING BULLETINS, AND ELECTRICAL SAFETY AUTHORITY INSPECTION REQUIREMENTS.
 - PAY ALL FEDERAL AND PROVINCIAL SALES TAXES APPLICABLE.
 - ALL EQUIPMENT SHALL BE NEW AND CSA (OR EQUIVALENT) APPROVED UNLESS OTHERWISE NOTED. SUPPLY, INSTALL WIRE AND CONNECT ALL EQUIPMENT SHOWN, SPECIFIED OR MENTIONED.
 - VISIT THE SITE OF THE PROJECT AND BECOME FAMILIAR WITH THE SITE CONDITIONS AND UNDERSTAND THE EXTENT OF WORK INVOLVED.
 - IT IS THE INTENT OF THESE DRAWINGS AND SPECIFICATIONS THAT THE CONTRACTOR PROVIDES COMPLETE AND OPERATIONAL SYSTEMS AS REQUIRED. ANY MISCELLANEOUS ITEMS, HARDWARE, DEVICES, WIRING, HANGERS, SUPPORTS, INSERTS, SLEEVES, ETC. MUST BE PROVIDED AND INCLUDED IN THE BID.
 - SUBMIT ONE (1) DIGITAL COPY OF SHOP DRAWINGS FOR APPLICABLE LIGHTING FIXTURES AND CONTROLS, EXIT LIGHTS, EMERGENCY LIGHTS AND BATTERY UNITS, DISCONNECT SWITCHES, STARTERS, SWITCHES AND RECEPTACLES, FIRE ALARM SYSTEM, FIRE STOP, RACEWAYS AND FITTINGS, HAND DRYERS, PANELBOARDS AND SWITCHBOARDS TO CONSULTANT FOR REVIEW.
 - CONTRACTOR SHALL REVIEW EACH SHOP DRAWING AND PRODUCT DATA SHEET, PRIOR TO SUBMITTAL TO ENSURE THE PROPOSED PRODUCT IS CORRECT AS PER THE SPECIFICATIONS. CONTRACTOR SHALL ENDORSE CONFORMANCE TO SPECIFICATIONS AND INCLUDE COMPANY NAME, DATE AND SIGNATURE OF THE SUBMITTER.
 - STORE MATERIAL OFF GROUND IN DRY LOCATION INDOORS AND IN ACCORDANCE WITH MANUFACTURERS RECOMMENDATION.
 - ON COMPLETION OF PROJECT AND BEFORE FINAL PAYMENT, SUBMIT ONE (1) SET OF AS-BUILT DRAWINGS WITH ALL CHANGES AND BURIED SERVICES EXACT LOCATIONS NOTED THEREON. PROVIDE AS-BUILT DRAWINGS IN AUTOCAD FORMAT.
 - LABELING:** PROVIDE LAMACOID LABELS WHITE LETTERED ON BLACK BACKGROUND- 1/4" HIGH LETTERING ON ALL ELECTRICAL EQUIPMENT SUPPLIED, MOUNTED AND/OR CONNECTED BY THIS CONTRACT. STATE NAME, VOLTAGE AND SOURCE. RECEPTACLE COVERPLATES SHALL BE LABELLED WITH CIRCUIT NUMBERS WITH ADHESIVE TAPE TYPE NAMEPLATES. LABELS SHALL HAVE A NEAT CLEAN AND PROFESSIONAL APPEARANCE SIMILAR TO BROTHER P-TOUCH LABELER.
 - THOROUGHLY CLEAN ALL ELECTRICAL EQUIPMENT DURING CONSTRUCTION AND ON COMPLETION OF CONTRACT.
 - CONFER WITH ALL TRADES AND ARRANGE EQUIPMENT IN PROPER RELATION WITH OTHER APPARATUS, DUCTS, PIPES, ETC., AND WITH BUILDING CONSTRUCTION AND ARCHITECTURAL FINISHES.
 - GUARANTEE ALL MATERIAL AND WORKMANSHIP FOR A PERIOD OF ONE YEAR FROM DATE OF ACCEPTANCE BY
 - PROVIDE PAINTING OF ELECTRICAL EQUIPMENT TO REPAIR MINOR DAMAGE TO FINISH TO MATCH FACTORY APPLIED BAKED ENAMEL OR GALVANI ED FINISH. APPLY ONE COAT OF CORROSION RESISTANT PRIMER PAINT TO SUPPORTS MADE FROM FERROUS METALS. PAINT BOTH SIDES OF PLYWOOD BACKBOARDS PRIOR TO INSTALLATION WITH FIRE RETARDANT PAINT.
 - PROVIDE FIREPROOFING WHERE CABLES PASS THROUGH FLOORS OR FIRE RATED WALLS. PLUG AND PROVIDE APPROVED FIRE STOP AND SEAL WITH CAULKING COMPOUND ANY HOLES AND OPENINGS LEFT DUE TO DEMOLITION WORK. PRODUCT SHALL BE CANULC S115 CERTIFIED.
 - WIRING SHALL BE CONCEALED IN WALLS OR ABOVE CEILINGS UNLESS OTHERWISE APPROVED.
 - CONTRACTOR SHALL START-UP AND COMMISSION ALL EQUIPMENT AND SYSTEMS INSTALLED UNDER THIS CONTRACT. COMMISSIONING WORK SHALL BE COMPLETED TO THE SATISFACTION OF THE CONSULTANT PRIOR TO ACCEPTANCE OF WORK. LINE VOLTAGE AND LOW VOLTAGE LIGHTING CONTROL SYSTEM SHALL BE COMMISSIONED BY A THIRD PARTY.
 - WIRING FOR OTHER TRADES:**
 - PROVIDE POWER WIRING FOR ELECTRICAL EQUIPMENT OF OTHER TRADES AS NOTED ON THE DRAWINGS. PROVIDE STARTERS AND DISCONNECT SWITCHES. COORDINATE WITH MECHANICAL FOR EXACT POWER REQUIREMENT AND FINAL CONNECTION ESTABLISHED FROM SHOP DRAWINGS FOR THE EQUIPMENT.
 - PROVIDE CONTROL WIRING FOR ALL CONTROL DEVICES OPERATING AT 120V OR GREATER.
 - ALL CUTTING AND PATCHING** REQUIRED TO THE BUILDING FOR THE WORK SHALL BE INCLUDED UNDER THE CONTRACT AND MUST BE EXECUTED TO THE SATISFACTION OF THE CONSULTANT. REINFORCEMENT SHALL NEVER BE CUT WITHOUT PRIOR APPROVAL OF THE STRUCTURAL CONSULTANT. MAINTAIN INTEGRITY OF THE FIRE RATED ASSEMBLY WHERE PIERCED BY DUCTS AND CONDUITS.
 - DEFINITIONS:** FOLLOWING ARE DEFINITIONS OF WORDS FOUND IN THIS SPECIFICATION AND ON ASSOCIATED DRAWINGS.
 - "CONCEALED" - HIDDEN FROM NORMAL SIGHT IN FURRED - SPACES, SHAFTS, CEILING SPACES, WALLS, UNDERFLOOR, AND PARTITIONS.
 - "EXPOSED" - ALL ELECTRICAL WORK VISIBLE TO BUILDING OCCUPANTS.
 - "PROVIDE" - (AND ALL TENSES OF "PROVIDE") SUPPLY INSTALL, WIRE AND CONNECT COMPLETE.
 - "INSTALL" - (AND ALL TENSES OF "INSTALL")-INSTALL, WIRE AND CONNECT COMPLETE, PRODUCTS AND SERVICES SPECIFIED.
 - "SUPPLY" - SUPPLY ONLY.
 - "OR APPROVED EQUAL" - MATERIAL OR EQUIPMENT PROPOSED BY CONTRACTOR, IN LIEU OF THAT SPECIFIED, AS APPROVED BY CONSULTANT.
 - "AS INDICATED" - AS SHOWN ON DRAWINGS AND/OR NOTED IN SPECIFICATIONS.
 - ALL WIRING SHALL BE COLOUR CODED AS PER OESC AND BE IDENTIFIED WITH BRADY OR EQUIVALENT SELF-STICKING PERMACODE WIRE MARKERS. ALL JUNCTION BOXES IN CONCEALED CEILING SPACES SHALL BE LABELLED WITH PEN MARKER AS TO CIRCUITS CONTAINED THEREIN.
 - FASTENINGS AND SUPPORTS:**
 - SUPPORT EQUIPMENT, CONDUIT OR CABLES USING CLIPS, SPRING LOADED BOLTS, CLAMPS DESIGNED AS ACCESSORIES TO BASIC CHANNEL MEMBERS.
 - INSTALL FASTENINGS AND SUPPORT AS REQUIRED FOR EACH TYPE OF EQUIPMENT, CONDUIT AND CABLES AND IN ACCORDANCE WITH MANUFACTURERS RECOMMENDATION.
 - GROUNDING:** GROUND ALL EQUIPMENT IN ACCORDANCE WITH CODE REQUIREMENTS.
 - DISCONNECT SWITCHES:** FUSED AND NON-FUSED, HEAVY DUTY, QUICK-MAKE, QUICK-BREAK MECHANISM, LOAD BREAK TYPE WITH DOOR, HANDLE AND SWITCHING MECHANISM INTERLOCK, ARC EXTINGUISHERS, SILVER PLATED WIPE ACTION CONTACTS, AND SPRING REINFORCED FUSE CLIPS, OF SI ES INDICATED, CSA UL/C CERTIFIED. PROVIDE DISCONNECT SWITCHES AHEAD OF EACH PIECE OF EQUIPMENT WHERE NECESSARY TO MEET CODE REQUIREMENTS.
 - FUSES:** 200,000 RMS SYMMETRICAL INTERRUPTING RATING, HRCJ TYPE. FOR MOTOR PROTECTION: TIME DELAY 200,000A RMS SYMMETRICAL RATING, HRCI-TIME DELAY TYPE.
 - BREAKERS:** COMPATIBLE WITH EXISTING PANELS. BOLT-ON MOLDED CASE CIRCUIT BREAKERS, FULL MODULE, QUICK MAKE, QUICK BREAK TYPE FOR MANUAL AND AUTOMATIC OPERATION. GENERALLY THERMAL-MAGNETIC TRIPPING. ARC-FAULT BREAKERS SHALL BE COMBINATION ARC-FAULT INTERRUPTION TYPE. GFI BREAKERS SHALL BE CLASS-A TYPE THAT WILL TRIP WHEN A FAULT CURRENT TO GROUND IS 6mA OR MORE FOR PEOPLE PROTECTION.
 - MOTOR STARTERS:** CSA CERTIFIED EEMAC RATED, SI ED AS INDICATED COMPLETE WITH NEMA ENCLOSURE, SUITABLE FOR ENVIRONMENT IN WHICH INSTALLED. HALF SI ED STARTERS ARE NOT ACCEPTABLE. CONTROL TRANSFORMER 100VA OR LARGER 120V PROTECTED BY CONTROL FUSES. INCLUDE HAND-OFF/AUTO 3 POSITION MAINTAINED CONTACT, ON-OFF SELECTOR SWITCHES. PROVIDE 2-NG AND 2-NO. AUXILIARY CONTACTS. STARTERS SHALL HAVE THERMAL-MAGNETIC OVERLOAD RELAYS WITH EXTERNAL MANUAL RESET. ALL 3 PHASE STARTERS SHALL HAVE SINGLE PHASING PROTECTION.
 - BOXES FOR INDOOR USE:** CODE GAUGE ELECTRO-GALVANI ED STEEL FOR CONCEAL MOUNTING AND GALVANI ED CAST FERROUS OR CAST BRUSHED ALUMINUM FOR EXPOSED USE. UNLESS OTHERWISE NOTED.
 - FIXTURE BOXES:** ELECTRO-GALVANI ED STEEL 103mm (4") OCTAGON COMPLETE WITH 10mm (3/8") FIXTURE STUD WHERE NECESSARY.
 - WHERE OUTLET BOXES ARE INSTALLED IN EXTERIOR WALLS AND/OR INSULATED CEILING HAVING ASSOCIATED VAPOR BARRIERS ON THE WARM SIDE OF THE INSULATION AND WHERE OUTLET BOXES PERFORATE THE VAPOR BARRIER, PROVIDE ELECTRICAL BOX VAPOR BARRIERS BEHIND AND AROUND OUTLET BOXES.
 - SWITCHES AND RECEPTACLE BOXES SHALL BE 1104 TYPE FOR RECESSED MOUNTING. LOCATE SWITCHES ON LATCH SIDE OF DOORS. CHANGE LOCATION OF OUTLETS WITHIN 10 FEET OF ORIGINAL LOCATION WITH NO EXTRA COST PROVIDING INFORMATION IS GIVEN BEFORE INSTALLATION.
 - RECEPTACLES:** SPECIFICATION GRADE DUPLEX RECEPTACLE, 20A, 125VOLT, 2 POLE, 3-WIRE GROUNDING, NEMA 5-20R; FLUSH NYLON FACE, BACK AND SIDE WIRED, WHITE COLOUR, HUBBELL CAT. HBL 5362W OR EQUIVALENT BY PASS & SEYMOUR, TAMPER RESISTANT, MARKING AND RATING WHERE INDICATED.
 - GFCI RECEPTACLES:** SPECIFICATION GRADE, TAMPER RESISTANT, DUPLEX GFCI RECEPTACLE, 20A, 125 VOLT, TRIP LEVEL 4 TO 6 mA MEETING UL/C CLASS A CERTIFICATION. TRIP TIME 0.025 SECOND NOMINAL, A.I.C. 10,000

NOTES	PROJECT IDENTIFICATION	DRAWING IDENTIFICATION	ORIENTATION	SUB-CONSULTANT	PRIME CONSULTANT	DISCIPLINE SEAL	DRAWING SUBMISSION(S)	INTERNAL INFO															
THE CONTRACTOR SHALL CHECK AND VERIFY ALL DIMENSIONS AND REPORT ANY ERRORS OR OMISSIONS TO THE ARCHITECT PRIOR TO COMMENCING OR PROCEEDING WITH ANY WORK ON THIS PROJECT. ALL DRAWINGS AND SPECIFICATIONS ARE THE PROPERTY OF THE ARCHITECT COPYRIGHT 2019. THESE DRAWINGS AND SPECIFICATIONS ARE DESIGNED FOR THE CLIENT AND THE PROPERTY INDICATED ON THESE DRAWINGS ONLY AND SHALL NOT BE CONSTRUCTED FOR ANY OTHER CLIENT OR ANY OTHER PROPERTY. DO NOT SCALE DRAWINGS.	<p>ST. ANNE CATHOLIC SCHOOL UNIVERSAL WASHROOM 183 SNOW AVE, BLENHEIM, ONTARIO N0P 1A0</p> <p>AS-BUILT DOCUMENTS SITE PLAN APPROVAL BUILDING PERMIT BIDS DOCUMENTS CONTRACT DOCUMENTS CONSTRUCTION DOCUMENTS</p>	<p>LEI ENI, NOTES, SCHEMULES, ELECTRICAL SPECIFICATION</p>		<p>Jilani and Asuncion Consulting Engineers LONDON, ON 519.902.2956 416.828.4004 WWW.JACENG.CA</p> <p>JACE # 19-011</p>	<p>ROA studio inc. 67 King Street West, Chatham ON N7M 1C7 tel. 519.397.0943 email. info@roastudio.com</p>		<table border="1"> <thead> <tr> <th>NO.</th> <th>DESCRIPTION</th> <th>DATE</th> </tr> </thead> <tbody> <tr> <td>3</td> <td>ISSUED FOR BIDS</td> <td>05-31-2019</td> </tr> <tr> <td>2</td> <td>ISSUED FOR CLIENT REVIEW</td> <td>05-28-2019</td> </tr> <tr> <td>1</td> <td>99% OWNER'S REVIEW</td> <td>05-16-2019</td> </tr> <tr> <td></td> <td>NO. DESCRIPTION</td> <td>DATE</td> </tr> </tbody> </table>	NO.	DESCRIPTION	DATE	3	ISSUED FOR BIDS	05-31-2019	2	ISSUED FOR CLIENT REVIEW	05-28-2019	1	99% OWNER'S REVIEW	05-16-2019		NO. DESCRIPTION	DATE	<p>PROJECT ID: ROA19-012 DRAWN BY: J.LAINE REVIEWED BY: M.JILANI DATE: 05.31.2019 SCALE: AS NOTED</p>
NO.	DESCRIPTION	DATE																					
3	ISSUED FOR BIDS	05-31-2019																					
2	ISSUED FOR CLIENT REVIEW	05-28-2019																					
1	99% OWNER'S REVIEW	05-16-2019																					
	NO. DESCRIPTION	DATE																					

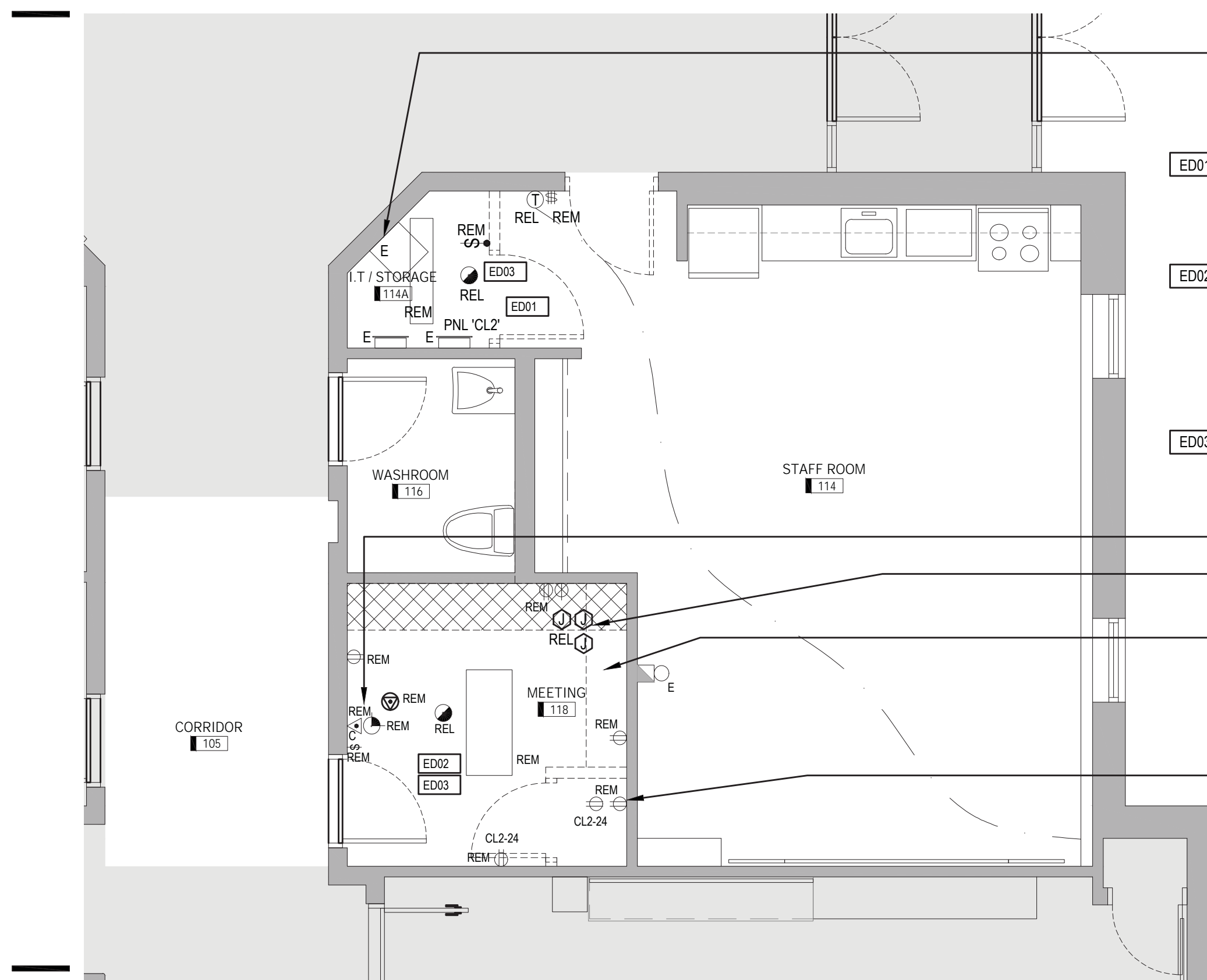

PARTIAL DEMOLITION FLOOR PLAN - ELECTRICAL
SCALE: 1/4"=1'-0"

- EXISTING INTERCOM CONTROL TELECOR XL TO REMAIN
- ED01** DISCONNECT AND REMOVE LIGHTING FIXTURES AND PROVIDE NEW LIGHTING AS PER NEW LAYOUT. DISCONNECT CEILING MOUNTED DEVICES FROM THE EXISTING TILES AND REINSTALL ON NEW CEILING TILES. ENSURE CIRCUIT INTEGRITY IS MAINTAINED.
- ED02** PHONE DEMARCATION HEADEND, POWER SUPPLIES AND WIRING BLOCKS, PATCH PANELS, SWITCHES AND CORDS. ALL EQUIPMENT ASSOCIATED WITH SCHOOL PHONES AND STRUCTURED CABLING SYSTEM (VOICE/DATA) WILL BE RELOCATED BY OWNERS CREW. CONTRACTOR TO REMOVE ALL REMAINING SURFACE RECEPTACLES AND WIRING BACK TO SOURCE AND REMOVE ALL REDUNDANT WIRING. REMOVE EXISTING LIGHTING FIXTURE AND PROVIDE NEW AS PER NEW LAYOUT.
- ED03** FIRE ALARM DEVICES TO BE REMOVED OR RELOCATED AS NOTED. VERIFY FIRE ALARM SYSTEM AS PER SPECIFICATIONS.
- REMOVE CLOCK AND INTERCOM AND TURN OVER TO OWNER.
- BLANKED-OFF JUNCTION BOXES. REWORK WIRING IN JUNCTION BOX SUCH THAT THESE JB ARE RELOCATED AND ARE ACCESSIBLE FROM THE STAFF ROOM SIDE OF THE WALL.
- PHONE DEMARCATION, SEE NOTE ED02
- I.T. RACK, SEE NOTE ED02

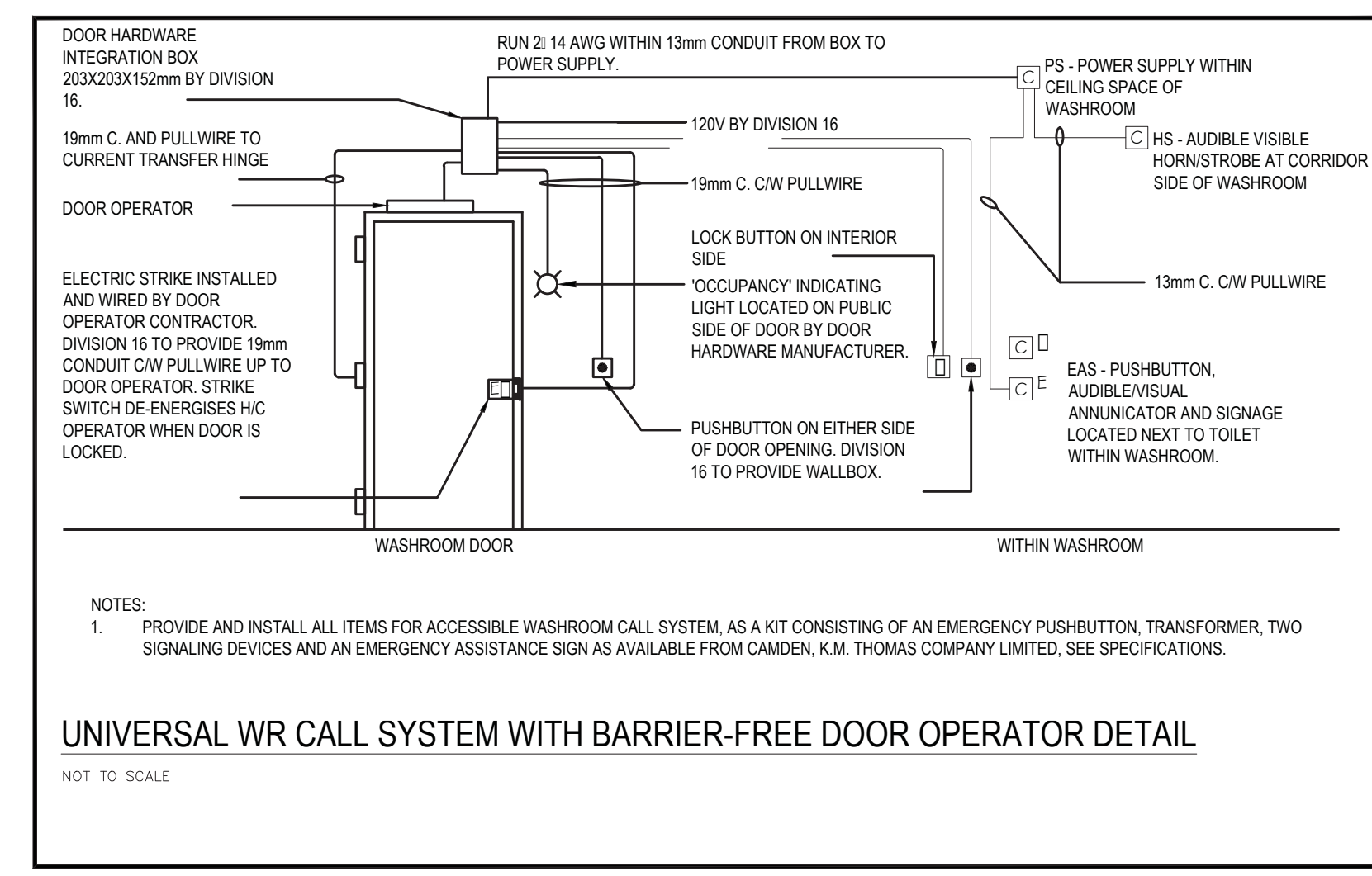

- UNIVERSAL WR CALL SYSTEM WITH BARRIER-FREE DOOR OPERATOR DETAIL**
NOT TO SCALE
- NOTES:**
- PROVIDE AND INSTALL ALL ITEMS FOR ACCESSIBLE WASHROOM CALL SYSTEM, AS A KIT CONSISTING OF AN EMERGENCY PUSHBUTTON, TRANSFORMER, TWO SIGNALING DEVICES AND AN EMERGENCY ASSISTANCE SIGN AS AVAILABLE FROM CAMDEN, K.M. THOMAS COMPANY LIMITED, SEE SPECIFICATIONS.
- LIGHTING NOTES:**
- MOTION SENSOR IN THE UNIVERSAL WR SHALL BE EQUIPPED FOR FAIL-SAFE LIGHT OPERATION AS PER OBC 12.2.4.1(2) AND TIMER SET FOR MINIMUM 15 MINUTE DURATION, WATTSTOPPER DT-355 OR EQUAL.
 - PROVIDE NEW EMERGENCY LIGHTING HEADS AND BATTERY UNIT INDICATED, 4W LED. SEE DRAWING E001.
 - ALL MOTION SENSORS TO BE COMPATIBLE WITH LED LIGHTING SPECIFIED.
 - UNIVERSAL WR 104'S MOTION SENSOR ALSO TO CONTROL THE EXH FAN.
 - EXISTING CIRCUITS INDICATED ARE TAKEN FROM EXISTING DRAWINGS AND NOT FROM EXHAUSTIVE SITE SURVEY.
 - INSTALL NEW LIGHTING FIXTURES AND CEILING DEVICES INTO NEW CEILING AND RECONNECT TO EXISTING CIRCUITS.

- POWER SYSTEMS NOTES:**
- UPDATE PANEL SCHEDULE WITH NEW CIRCUIT INFORMATION.

- DEMOLITION NOTES:**
- DISCONNECT AND REMOVE ALL LIGHT FIXTURES, SWITCHES, RECEPTACLES INDICATED UNLESS OTHERWISE NOTED. FROM WITHIN THE OUTLINED AREA. REWORK WIRING TO NEW LIGHTS. REMOVE WIRING OF EXISTING RECEPTACLES TO NEAREST RECEPTACLE RETAINED.

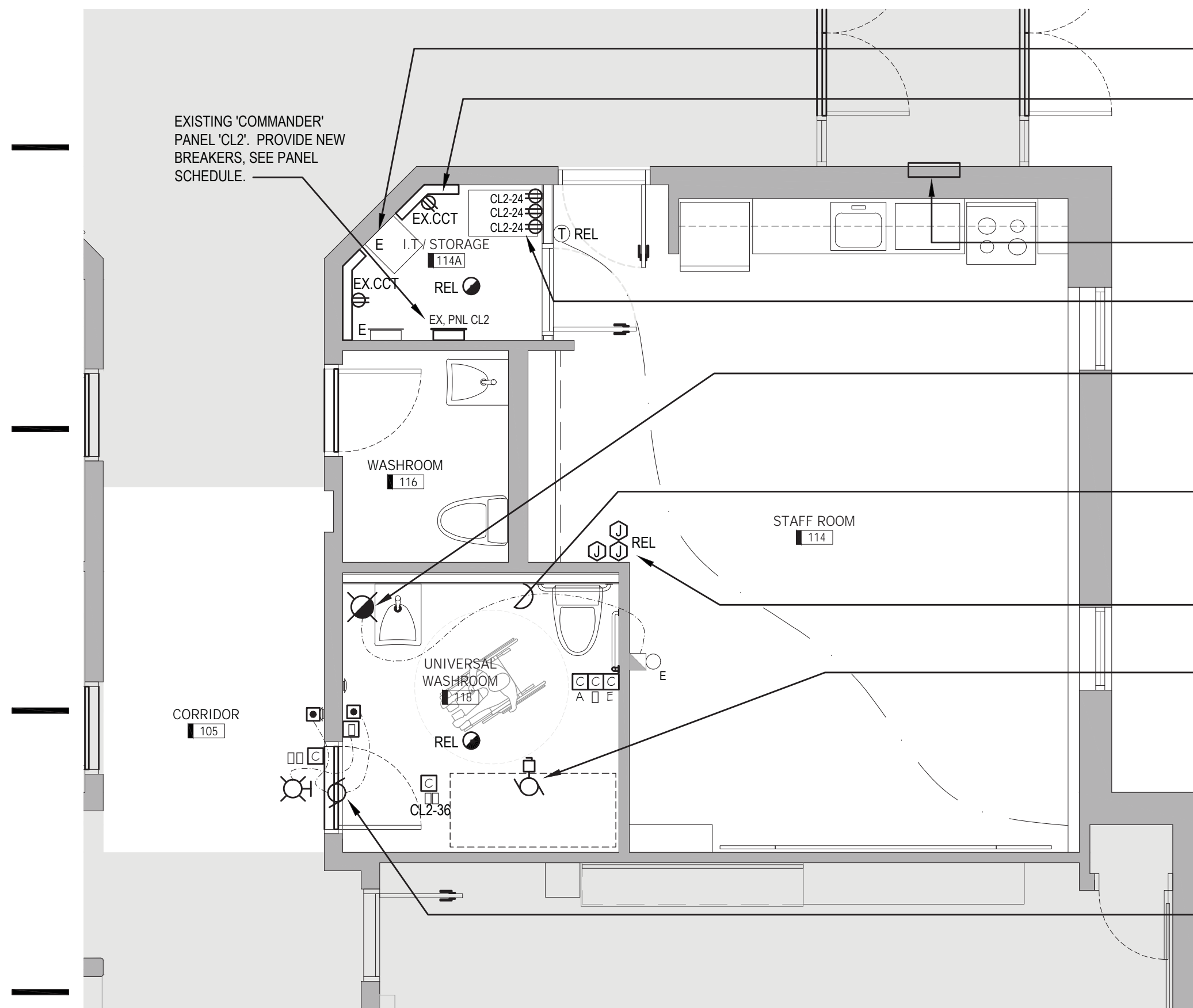

PARTIAL FLOOR PLAN - POWER SYSTEMS
SCALE: 1/4"=1'-0"

- EXISTING INTERCOM CONTROL TELECOR XL TO REMAIN
- LINE BLANK WALLS NOTED WITH 3/4" PLYWOOD PAINTED, AND PROVIDE TWO RECEPTACLES ON EXISTING CIRCUIT (FROM PREV. MTG RM) FOR RELOCATED TELEPHONE EQUIPMENT AND MISC. USE. (OWNER WILL RELOCATE TELEPHONE DEMARC EQUIPMENT AND COORDINATE WITH TELEPHONE COMPANY.)
- EXISTING EDWARDS 6616 FIRE ALARM PANEL TO REMAIN. PROVIDE ADDITIONAL MODIFICATIONS / MODULES NECESSARY.
- EXISTING I.T. RACK RELOCATED BY OWNER'S FORCES. PROVIDE RECEPTACLES AND CONNECT TO EXISTING CIRCUIT.
- PROVIDE A FIRE ALARM 'FREE-RUNNING' STROBE ON EXISTING BELL CIRCUIT. PROVIDE NECESSARY MODIFICATIONS AND COMPONENTS TO EXISTING EDWARDS 6616 FIRE ALARM SYSTEM FOR A STROBE CIRCUIT.
- TIE NEW F.A. STROBE (EDWARDS | G1F-VM) INTO NEAREST 24V F.A. DEVICE AS COORDINATED WITH F.A. MANUFACTURER. VERIFY TIE-IN LOCATION ONSITE. COORDINATE ADDITIONAL CUTTING AND PATCHING REQUIRED WITH GENERAL CONTRACTOR.
- RELOCATED JUNCTION BOXES FROM MEETING RM /UWR. PROVIDE ACCESS FROM STAFF ROOM.
- EXH FAN EF1, 50W, 120V, CONTROLLED WITH LIGHTING SWITCH AND ON SAME LIGHTING CIRCUIT.
- BF DOOR OPERATOR, FHP, 120V. PROVIDE 15A-1P DEDICATED CIRCUIT. CL2-38.

E	EXISTING TO REMAIN
REL	RELOCATE
REM	REMOVAL
REPL	REPLACE

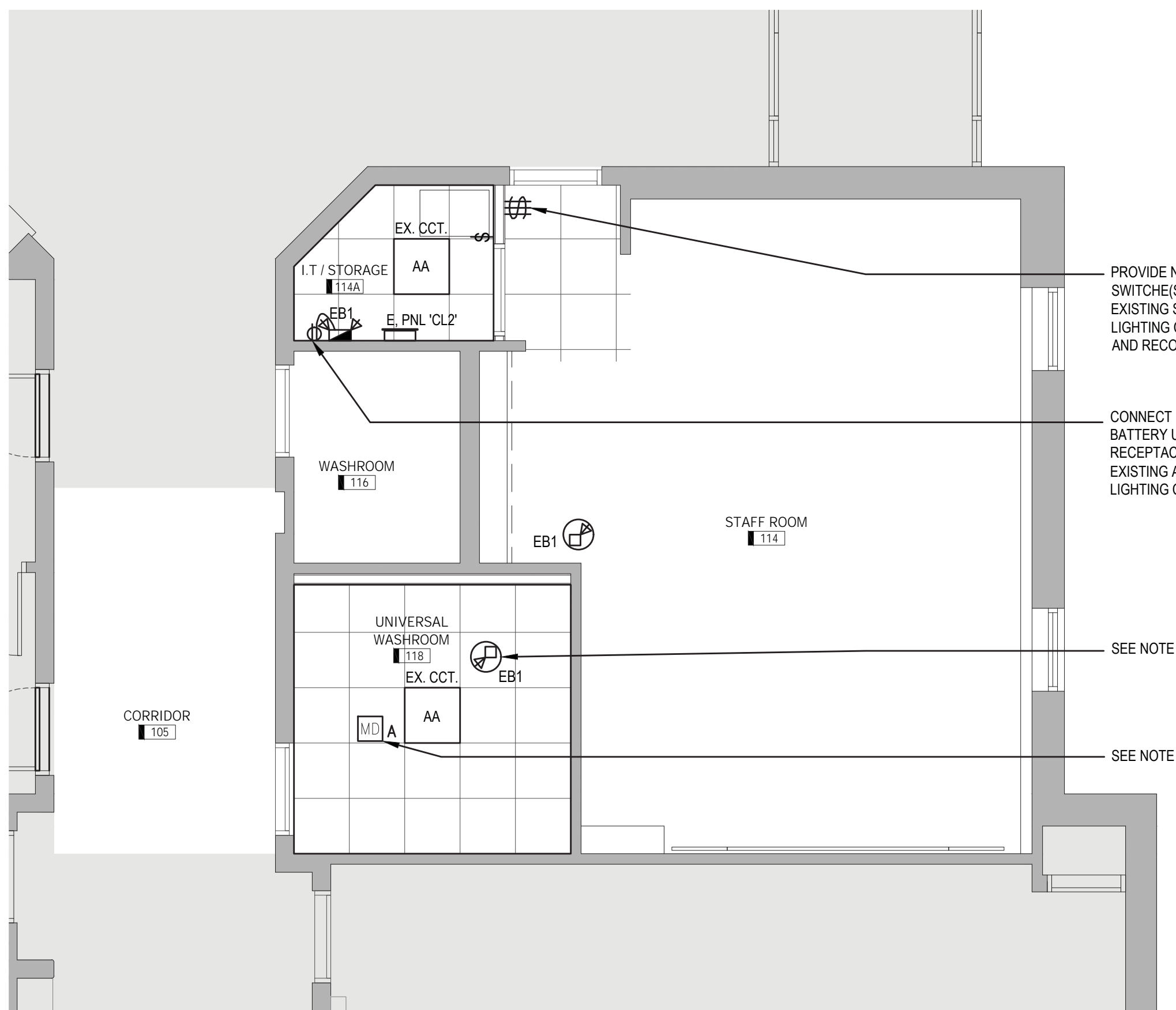

PARTIAL FLOOR PLAN - LIGHTING
SCALE: 1/4"=1'-0"

- PROVIDE NEW SWITCH(S) TO MATCH EXISTING STAFF ROOM LIGHTING CONTROLS AND RECONNECT.
- CONNECT NEW BATTERY UNIT RECEPTACLE TO EXISTING AREA LIGHTING CIRCUIT.
- SEE NOTE L2
- SEE NOTE L1,L4

NOTES

THE CONTRACTOR SHALL CHECK AND VERIFY ALL DIMENSIONS AND REPORT ANY ERRORS OR OMISSIONS TO THE ARCHITECT PRIOR TO COMMENCING OR PROCEEDING WITH ANY WORK ON THIS PROJECT. ALL DRAWINGS AND SPECIFICATIONS ARE THE PROPERTY OF THE ARCHITECT COPYRIGHT 2019. THESE DRAWINGS AND SPECIFICATIONS ARE DESIGNED FOR THE CLIENT AND THE PROPERTY INDICATED ON THESE DRAWINGS ONLY AND SHALL NOT BE CONSTRUCTED FOR ANY OTHER CLIENT OR ANY OTHER PROPERTY. DO NOT SCALE DRAWINGS.

PROJECT IDENTIFICATION

**ST. ANNE CATHOLIC SCHOOL
UNIVERSAL WASHROOM**
183 SNOW AVE,
BLENHEIM, ONTARIO
N0P 1A0

AS-BUILT DOCUMENTS | SITE PLAN APPROVAL | BUILDING PERMIT | BIDS DOCUMENTS | CONTRACT DOCUMENTS | CONSTRUCTION DOCUMENTS

DRAWING IDENTIFICATION

**PARTIAL FLOOR PLANS -
DEMOLITION, LIGHTING, POWER
SYSTEMS, UNIVERSAL WR DETAIL**

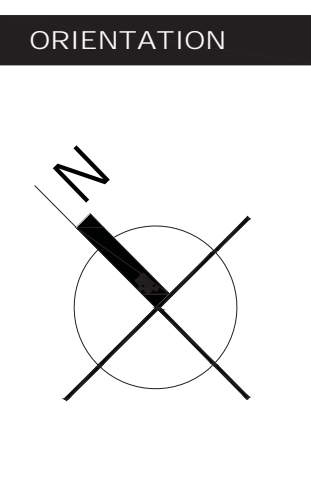

SUB-CONSULTANT

**Jilani and Asuncion
Consulting Engineers**
LONDON, ON | 519.902.2956 | 416.828.4004 | WWW.JIACENG.CA
JACE #19-011

PRIME CONSULTANT

ROA studio inc.
67 King Street West, Chatham ON N7M 1C7
tel. 519.397.0943
email. info@roastudio.com

DISCIPLINE SEAL

DRAWING SUBMISSION(S)

NO.	DESCRIPTION	DATE	MM-DD-YY
3	ISSUED FOR BIDS	05-31-2019	
2	ISSUED FOR CLIENT REVIEW	05-28-2019	
1	99% OWNER'S REVIEW	05-16-2019	

INTERNAL INFO

ELECTRICAL

PROJECT ID: ROA19-012
DRAWN BY: J.LAINE
REVIEWED BY: M.JILANI
DATE: 05.31.2019
SCALE: AS NOTED